

# \*TM 10-8340-240-12&P

---

## TECHNICAL MANUAL

### OPERATOR'S AND UNIT MAINTENANCE MANUAL, INCLUDING REPAIR PARTS AND SPECIAL TOOLS LIST FOR MODULAR GENERAL PURPOSE TENT SYSTEM (MGPTS)

#### Type I Version (Green)

NSN 8340-01-456-3633 (SMALL)  
NSN 8340-01-456-3628 (MEDIUM)  
NSN 8340-01-456-3674 (LARGE)

#### Type II Version (Green)

NSN 8340-01-516-6860 (SMALL)  
NSN 8340-01-516-6861 (MEDIUM)  
NSN 8340-01-516-6863 (LARGE)

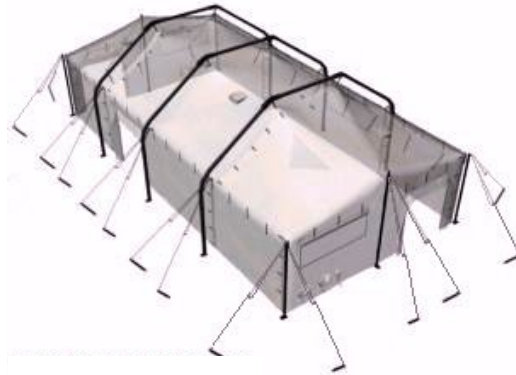

#### Type I Version (Tan)

NSN 8340-01-491-1507 (SMALL)  
NSN 8340-01-491-1515 (MEDIUM)  
NSN 8340-01-491-1479 (LARGE)

#### Type II Version (Tan)

NSN 8340-01-516-6859 (SMALL)  
NSN 8340-01-516-6864 (MEDIUM)  
NSN 8340-01-516-6865 (LARGE)

DISTRIBUTION STATEMENT A – Approved for public release: Distribution unlimited.

\*TM 10-8340-240-12&P dated 30 June 2005 supersedes TM 10-8340-240-12&P dated 21 June 2000 and all changes thereto.

---

**HEADQUARTERS, DEPARTMENT OF THE ARMY**

**30 June 2005**



## WARNING SUMMARY

This warning summary contains general safety warnings and hazardous materials warnings that must be understood and applied during operation of this equipment. Failure to observe these precautions could result in serious injury or death to personnel. Also included are explanations of safety and hazardous materials icons within this technical manual.

### EXPLANATION OF SAFETY WARNING ICONS



**ELECTRICAL** – Electrical wire to hand with electricity symbol running through human body shows that shock hazard is present.



**FIRE** – Flame shows that a material may ignite and cause burns.



**HEAVY OBJECT** – Human figure stooping over heavy object shows physical injury potential from improper lifting technique.



**HEAVY PARTS** – Heavy object pinning human figure against wall shows that heavy, moving parts present a danger to life or limb.



**MOVING PARTS** – Hand with fingers caught between rollers shows that the moving parts of the equipment present a danger to life or limb.



**VAPOR** – Human figure in a cloud shows that material vapors present a danger to life or health.



**TRIPPING** – Line shows that objects on the floor may cause tripping.



**WARNING**

All tent guy ropes must be staked down.

Always begin raising the tent from downwind and lowering from the upwind side. This will prevent wind from getting underneath and moving the partially raised unsecured tent.

Stakes at the feet of the pole must be used to prevent excessive movement of the MGPTS in high winds. Ensure all personnel and equipment have been removed from tent before striking or lowering. Failure to stake and tie down tent may result in injury to personnel.



**WARNING**

Do not use any type of non-vented heaters. The use of non-vented heaters will cause the accumulation of Carbon monoxide gas. Carbon Monoxide gas is not visible and has no smell. If symptoms of headache, dizziness, fatigue, nausea, or irregular breathing occur, move affected personnel to fresh air. Failure to comply with this warning may result in personal injury or death.

All fuel burning heaters consume oxygen. Adequate ventilation must be maintained at all times. Keep roof vents clear of snow, ice or debris. Open doors, windows, flaps, hook and loop fastener wall closures as needed to introduce sufficient fresh air to replace oxygen consumed by heaters. If symptoms of headache, dizziness, fatigue, nausea, or irregular breathing occur, move affected personnel to fresh air. Failure to comply with this warning may result in personal injury or death.

Do not run internal combustion engines inside tent without sidewalls rolled up. Failure to comply with this warning may result in personal injury or death.

Use seam sealer and adhesive in well ventilated areas only. Use personal protective equipment to prevent inhalation of fumes. In case of dizziness leave area immediately.



---

**WARNING**

---

Lethal voltage is present when a light set is connected to its power source. Disconnect from the power source before inspecting or repairing any electrical component. Electrical shock or death may result from failure to acknowledge this warning.



---

**WARNING**

---

Mid and End Sections are heavy. Six personnel are required to lift each section. Always lift with your legs not with your back.

Pole bottoms may slip or kick out on hard or slippery surfaces. Maintain control of side pole and center poles at all times when lifting. Two persons are required to lift and position each side pole, three persons are required to lift each center pole and four persons are required to lift each Arch, Tent Frame.

Three personnel are required to put center pole in tent and raise it. Always lift with your legs, not your back. Failure to comply may result in injury to personnel.



---

**WARNING**

---

Do not smoke when using seam sealer or adhesive. Do not use seam sealer, or adhesive around open flame. Seam sealer is flammable. Failure to comply may result in injury to personnel.



---

**WARNING**

---

Use care to ensure fingers, or other parts are not caught in center pole and Arch, Tent Frame hinge points. Failure to comply may result in injury to personnel.



---

**WARNING**

---

Eliminate the possibility of tripping. Clear fabric and guy lines. Injury to personnel may result from falls.

INSERT LATEST UPDATED PAGES/WORK PACKAGES. DESTROY SUPERSEDED DATA.

**LIST OF EFFECTIVE PAGES/ WORK PACKAGES**

NOTE: The portion of text affected by the changes is indicated by a vertical line in the outer margins of the page. Changes to illustrations are indicated by miniature pointing hands. Changes to wiring diagrams are indicated by shaded areas.

Dates of issue for original and changed pages/work packages are:

Original ..1 .. 30 June 05

**TOTAL NUMBER OF PAGES FOR FRONT AND REAR MATTER IS 30 AND TOTAL NUMBER OF WORK PACKAGES IS 41 CONSISTING OF THE FOLLOWING:**

<b>Page/WP No.</b>	<b>*Change No.</b>	<b>Page/WP No.</b>	<b>* Change No.</b>	<b>Page/WP No.</b>	<b>* Change No.</b>
Title .....	0				
a-d .....	0				
A/(B Blank) .....	0				
i – iii/(iv Blank) .....	0				
WP 0001 00 – 0041 00 .....	0				
Index 1 – Index 3/(4 Blank) .....	0				

\* Zero in this column indicates an original page or work package.





HEADQUARTERS  
DEPARTMENT OF THE ARMY  
Washington, D.C., 30 JUNE 2005

## TECHNICAL MANUAL

### OPERATOR'S AND UNIT MAINTENANCE MANUAL, INCLUDING REPAIR PARTS AND SPECIAL TOOLS LIST FOR

### MODULAR GENERAL PURPOSE TENT SYSTEM (MGPTS)

Type I Version (Green)  
NSN 8340-01-456-3633 (SMALL)  
NSN 8340-01-456-3628 (MEDIUM)  
NSN 8340-01-456-3674 (LARGE)

Type II Version (Green)  
NSN 8340-01-516-6860 (SMALL)  
NSN 8340-01-516-6861 (MEDIUM)  
NSN 8340-01-516-6863 (LARGE)

Type I Version (Tan)  
NSN 8340-01-491-1507 (SMALL)  
NSN 8340-01-491-1515 (MEDIUM)  
NSN 8340-01-491-1479 (LARGE)

Type II Version (Tan)  
NSN 8340-01-516-6859 (SMALL)  
NSN 8340-01-516-6864 (MEDIUM)  
NSN 8340-01-516-6865 (LARGE)

#### REPORTING ERRORS AND RECOMMENDING IMPROVEMENTS

You can help improve this manual. If you find any mistakes or if you know of a way to improve the procedures, please let us know. Mail your letter together with DA Form 2028 (Recommended Changes to Publications and Blank Forms), located in the back of this manual, directly to: Commander, U.S. Army Tank-Automotive Command and Armament Command, ATTN: AMSTA-LC-CECT, Kansas Street, Natick, MA 01760- 5052. You may also send in your recommended changes via electronic mail directly to: <amssbriml@natick.army.mil> A reply will be furnished to you. Instructions for sending an electronic 2028 may be found at the back of this manual immediately preceding the hard copy 2028.

**DISTRIBUTION STATEMENT A** – Approved for public release. Distribution unlimited.

\*TM 10-8340-240-12&P dated 30 June 2005 supersedes TM 10-8340-240-12&P dated 21 June 2000 and all changes thereto.

## TABLE OF CONTENTS

	<u>WP Sequence No.</u>
WARNING SUMMARY	a
LIST OF EFFECTIVE PAGES	A
HOW TO USE THIS MANUAL	iii
GENERAL INFORMATION	0001 00

**TABLE OF CONTENTS - continued**

**WP Sequence No.**

**CHAPTER 1 - DESCRIPTION AND THEORY OF OPERATION**

Equipment Description and Data ..... 0002 00  
 Theory of Operation ..... 0003 00

**CHAPTER 2 - OPERATOR INSTRUCTIONS**

Type I-Operation Under Usual Conditions ..... 0004 00  
 Type II-Operation Under Usual Conditions ..... 0005 00  
 Floor-Operation Under Usual Conditions ..... 0006 00  
 Liner-Operation Under Usual Conditions ..... 0007 00  
 Plenum-Operation Under Usual Conditions ..... 0008 00  
 Operation Under Unusual Conditions ..... 0009 00

**CHAPTER 3 - OPERATOR MAINTENANCE INSTRUCTIONS**

Service Upon Receipt ..... 0010 00  
 Preventive Maintenance Check and Services (PMCS), Introduction ..... 0011 00  
 Preventive Maintenance Check and Services (PMCS), Including Lubrication Instructions ..... 0012 00  
 Fabric Assembly End Module and Fabric Assembly Mid Module Repair and Replace ..... 0013 00  
 Fabric Assembly End Module and Fabric Assembly Mid Module Small Diameter Repair ..... 0014 00  
 Tent Pole (End), Tent Pole (Side), Tent Pole (Y) and Frame Arch Assembly ..... 0015 00

**CHAPTER 4 - UNIT MAINTENANCE INSTRUCTIONS**

Fabric Assembly End Module and Fabric Assembly Mid Module ..... 0016 00  
 Fabric Assembly End Module and Fabric Assembly Mid Module ..... 0017 00  
 Fabric Assembly End Module and Fabric Assembly Mid Module ..... 0018 00

**CHAPTER 5 - SUPPORTING INFORMATION**

References ..... 0019 00  
 Maintenance Allocation Chart (MAC), Introduction ..... 0020 00  
 Maintenance Allocation Chart (MAC) ..... 0021 00  
 Repair Parts and Special Tools List (RPSTL), Introduction ..... 0022 00  
 Group 00 Modular General Purpose Tent System (MGPTS) (Small, Medium, Large) ..... 0023 00  
 Group 01 Tent Section, End Module Fabric (Type I and II) ..... 0024 00  
 Group 02 Tent Assembly, Mid Module Fabric ..... 0025 00  
 Group 03 Tent Pole (Side) ..... 0026 00  
 Group 04 Pole, Tent (End) ..... 0027 00  
 Group 05 Pole, Tent (Y) ..... 0028 00  
 Group 06 Arch, Tent Frame ..... 0029 00  
 Group 07 Stake, Hold Down, Tent ..... 0030 00  
 Group 08 Bags, Tent ..... 0031 00  
 Group 09 Floor, Tent ..... 0032 00  
 Group 10 Liner ..... 0033 00  
 Group 11 Plenum ..... 0034 00  
 Group 12 Repair Kit ..... 0035 00  
 Group 99 Bulk Material ..... 0036 00  
 National Stock Number Index ..... 0037 00  
 Part Number Index ..... 0038 00  
 Components of End Item (COEI) and Basic Issue Items (BII) List ..... 0039 00  
 Additional Authorization List (AAL) ..... 0040 00  
 Expendable and Durable Items List ..... 0041 00

**ALPHABETICAL INDEX** ..... Index-1

## HOW TO USE THIS MANUAL

This Operator's and Unit Manual for Modular General Purpose Tent System (MGPTS) contains general information, operating instructions, maintenance procedures and operator Preventive Maintenance Checks and Services (PMCS) for the MGPTS. Use the Table of Contents or the index to locate particular sections of this manual.

The manual is divided into chapters and work packages (WP) that are numbered in sequence. Pages and tables are numbered by WP. For example, page 3 of WP 2 is marked 0002 00-3, the second table of WP 1 is labeled Table 2. To quickly find specific information, use the Table of Contents on page i. The Table of Contents lists work packages by chapter. For example, the Table of Contents tells you that Chapter 1, Equipment Description and Data, is in WP 0002 00. The Table of Contents on page i tells you the exact WP where each section of each chapter is located. The RPSTL located in WP 0023 00 lists and authorizes spares and repair parts. A comprehensive alphabetical index starts on page I1 at the end of the manual.



---

**OPERATOR'S AND UNIT MAINTENANCE****MODULAR GENERAL PURPOSE TENT SYSTEM (MGPTS)****NSN 8340-01-456-3633, NSN 8340-01-456-3628, NSN 8340-01-456-3674****NSN 8340-01-516-6860, NSN 8340-01-516-6861, NSN 8340-01-516-6863****NSN 8340-01-491-1507, NSN 8340-01-491-1515, NSN 8340-01-491-1479****NSN 8340-01-516-6859, NSN 8340-01-516-6864, NSN 8340-01-516-6865****GENERAL INFORMATION**

---

**SCOPE**

This manual contains operator and unit level instructions/operations and care/maintenance for the Modular General Purpose Tent System (MGPTS). The manual covers site preparation, erection, care/maintenance, striking, cleaning, repair and storage of the MGPTS, for both Type I and Type II.

The MGPTS was designed to provide protection for personnel and equipment from the debilitating effects of continuous exposure in climatic categories: hot, basic, cold, wet climate, extreme heat and severe cold. It can also be utilized for medical units, troop billeting, command and control, humanitarian/disaster relief, storage applications, and limited organizational maintenance functions.

This system will replace the current General Purpose (GP) Tents, which require excessive time to erect and strike, lack commonality of parts, and cannot be complexed together with other tents in the inventory.

**MAINTENANCE FORMS AND RECORDS**

Department of the Army forms and procedures used for equipment maintenance will be those prescribed by DA PAM 738-750, Functional Users Manual for the Army Maintenance Management System (TAMMS); DA PAM 738-751, Functional Users Manual for the Army Maintenance Management System-Aviation (TAMMS-A); or AR 700-138, Army Logistics Readiness and Sustainability.

**REPORTING EQUIPMENT IMPROVEMENT RECOMMENDATIONS (EIR)**

If your MGPTS needs improvement, let us know. Send us an EIR. You, the user, are the only one who can tell us what you don't like about your equipment. Let us know why you don't like the design or performance. Put it on SF 368 (Product Quality Deficiency Report). Mail it to the address specified in DA PAM 738-750, Functional Users Manual for the Army Maintenance Management System (TAMMS), or as specified by the acquiring activity. We will send you a reply.

## **CORROSION PREVENTION AND CONTROL (CPC)**

Corrosion Prevention and Control (CPC) of Army material is a continuing concern. It is important that any corrosion problems with this item be reported so that the problem can be corrected and improvements can be made to prevent the problem in future items.

While corrosion is typically associated with rusting of metals, it can also include deterioration of other materials, such as rubber and plastic. Unusual cracking, softening, swelling, or breaking of these materials may be a corrosion problem.

If a corrosion problem is identified, it can be reported using a SF 368, Product Quality Deficiency Report. Use of key words such as "corrosion," "rust," "deterioration," or "cracking" will ensure that the information is identified as a CPC problem.

This form should be submitted to the address specified in DA PAM 738-750, Functional Users Manual for the Army Maintenance Management System (TAMMS).

## **DESTRUCTION OF ARMY MATERIAL TO PREVENT ENEMY USE**

Destruction of Army material to prevent enemy use shall be in accordance with TM 750-244-3, Procedure for Destruction of Army Material to Prevent Enemy Use.

## **PREPARATION FOR STORAGE OR SHIPMENT**

Refer to WP 0004 00 for Type I or WP 0005 00 for Type II to prepare the MGPTS for storage and shipment.

## **WARRANTY INFORMATION**

Warranty. A product registration card with identification numbers is packed with each tent. The registration card is packaged along with setup instructions in a clearly identifiable envelope inside the shipping container. This envelope will instruct the user how to send in the product registration card to Eureka! Tent when the tent is first deployed. The three-year warranty will begin on the date the Registration is received at Eureka! Tent. No warranty claims will be allowed against a product where a Product Registration card has not been received.

Limited Warranty. The manufacturer warrants the Modular General Purpose Tent Systems are free from major defects in materials or workmanship and will meet performance specifications as listed in sections 3.3 - 3.6.6 in solicitation number DAAK60-97-R-9622 for a period of three years after first deployment. If defects are found, call our Customer Service Center at 1-800-847-1460 for a return authorization. If, after inspection, we find that the product was defective in material or workmanship, we shall, at our option, either repair or replace it without charge. We are not responsible for normal wear and tear or for damage caused by accidents, misuse, alterations, or improper installations. Additionally, although we manufacture our products with quality fabrics, we are not responsible for the negative effects of climate, pollution or acts of God beyond those outlined in sections 3.3 - 3.6.6 in solicitation number DAAK60-97-R-9622. Because tents are temporary structures, it is necessary that each unit be installed and maintained according to the manufacturer's instructions.

**WARRANTY INFORMATION - continued**

There are no other express warranties beyond the terms of this limited warranty. In no event shall the manufacturer be liable for incidental or consequential damages.

**NOMENCLATURE CROSS-REFERENCE LIST**

<b>Common Name</b>	<b>Official Name</b>
Tent	Modular General Purpose Tent System
Vestibule	Vestibule
Lights	Light Set, Fluorescent, Portable
End section	Tent Section, End Module Fabric
Mid section	Tent Section, Mid Module Fabric
Arch assemblies	Arch, Tent Frame
Y pole	Pole, Tent (Y)
End pole	Pole, Tent (End)
Side pole	Tent Pole (Side)

**LIST OF ABBREVIATIONS/ACRONYMS**

AAL	Additional Authorized List	MTOE	Modified Table of Organization and Equipment
BII	Basic Issue Item	NHA	Next Higher Assembly
CAGEC	Commercial and Government Entity Code	NSN	National Stock Number
COEI	Component of End Item	NIIN	National Item Identification Number
CPC	Corrosion Prevention Control	PMCS	Preventative Maintenance Checks and Services
DS2	Decontamination Solution (Ready to Use)	RPSTL	Repair Parts and Special Tools List
ECU	Environmental Control Unit	SMR	Source, Maintenance, and Recoverability
EIR	Equipment Improvement Recommendation	SRA	Specialized Repair Activity
ft	Feet	STB	Supertropical Bleach—Decontamination Agent
ft <sup>3</sup>	Cubic feet	TAMMS	The Army Maintenance Management System
HCI	Hardness Critical Item	TEMPER	Tent, Extendable, Modular, Personnel
GP	General Purpose	TMDE	Test, Measurement, and Diagnostic Equipment
in.	Inch	TOE	Table of Organization and Equipment
ISO	International Standards Organization	U/M	Unit of Measure
MAC	Maintenance Allocation Chart	UOC	Usable On Code
MGPTS	Modular General Purpose Tent System	UUT	Under Unit Test

**SAFETY, CARE AND HANDLING**

Always observe **Warnings**, **Cautions**, and **Notes** in the manual. They appear before appropriate procedures. Be sure you read and understand each of the Warnings, Cautions, and Notes. Failure to observe them may cause damage to yourself, others, or equipment.

**END OF WORK PACKAGE**



**CHAPTER 1**

**DESCRIPTION AND  
THEORY OF OPERATION  
FOR  
MODULAR GENERAL PURPOSE TENT SYSTEM (MGPTS)**



**OPERATOR'S AND UNIT MAINTENANCE****MODULAR GENERAL PURPOSE TENT SYSTEM (MGPTS)**

NSN 8340-01-456-3633, NSN 8340-01-456-3628, NSN 8340-01-456-3674

NSN 8340-01-516-6860, NSN 8340-01-516-6861, NSN 8340-01-516-6863

NSN 8340-01-491-1507, NSN 8340-01-491-1515, NSN 8340-01-491-1479

NSN 8340-01-516-6859, NSN 8340-01-516-6864, NSN 8340-01-516-6865

**EQUIPMENT DESCRIPTION AND DATA****EQUIPMENT CHARACTERISTICS, CAPABILITIES, AND FEATURES**

The MGPTS is a frame supported (Type II) or pole supported (Type I) modular structure. Either version can be quickly erected under normal conditions. The MGPTS is issued in three sizes: small, medium, and large and two versions: Type I or Type II and in two exterior colors, green or tan. The MGPTS can also be complexed in various combinations of length.

**Characteristics:**

- Modular
- Lightweight structure
- Pole supported (Type I)
- Frame supported (Type II)

**Capabilities and Features:**

- Provides environmental protection for personnel, command and control, support, or maintenance
- Flexible configuration
- Complexed with other types of shelters
- Accommodates external environmental control unit

**Setup:**

- |        |                              |
|--------|------------------------------|
| Small  | four personnel in 27 minutes |
| Medium | four personnel in 36 minutes |
| Large  | six personnel in 67 minutes  |

**LOCATION AND DESCRIPTION OF MAJOR COMPONENTS****Type I - The major components of the MGPTS are as follows:**

Tent Poles (Side) **(1)** are 7-ft long fixed-length aluminum poles. At the top of the side poles, there is a cap assembly **(2)**. The base of the poles has a base plate with a stake tube. Guy ropes are attached to the cap assembly.

LOCATION AND DESCRIPTION OF MAJOR COMPONENTS – continued

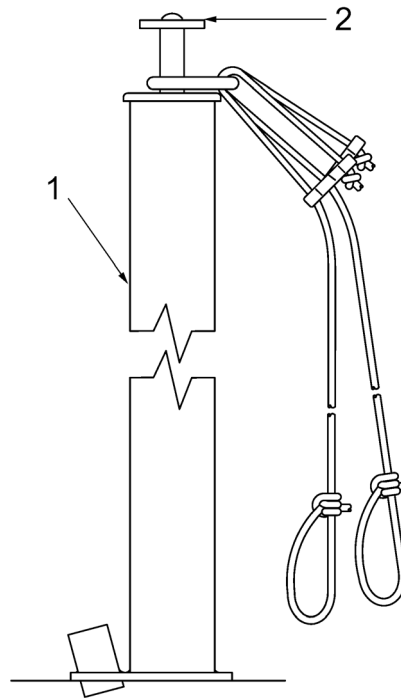

Pole, Tents (End) **(3)** are seven foot long aluminum poles extendable to nine feet. The end poles are extended by first pulling out a locking pin **(4)** on the upper leg assembly. Then pulling the upper leg assembly to the upper hole and pushing in the pin. At the top of the end poles there is a cap assembly, and the base of the poles have a stake tube. Guy ropes are attached to the cap assembly.

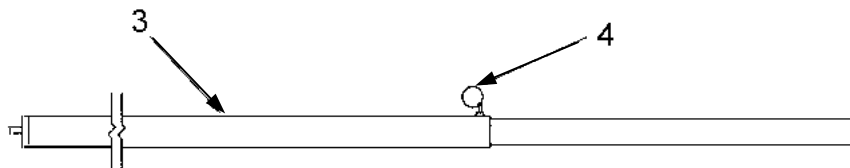

Pole, Tents (Y) **(5)** are aluminum poles that resemble a Y. The upper arms of the Y fold down for storage and transport. The base of the tent pole (Y) also has a stake tube.

End Sections **(6)** are made of polyester fabric that is white inside and green or tan on the outside. The roof, side and end walls are part of the end section. Attachment to other sections is made using grommets and becket lacing. Two flaps are buckled over the becket lacing. This makes the tent weather proof and light secure. Every end section has a door, window, ECU and electrical feed throughs.

**LOCATION AND DESCRIPTION OF MAJOR COMPONENTS - continued**

Mid Sections (**7**) are made of polyester fabric that is white inside and green or tan on the outside. The roof and sidewalls are part of the mid section. Attachments to other sections are made using grommets and becket lacing. Two flaps are buckled over the becket lacing. This creates a weather proof and light secure tent. Every mid section has a door and a window.

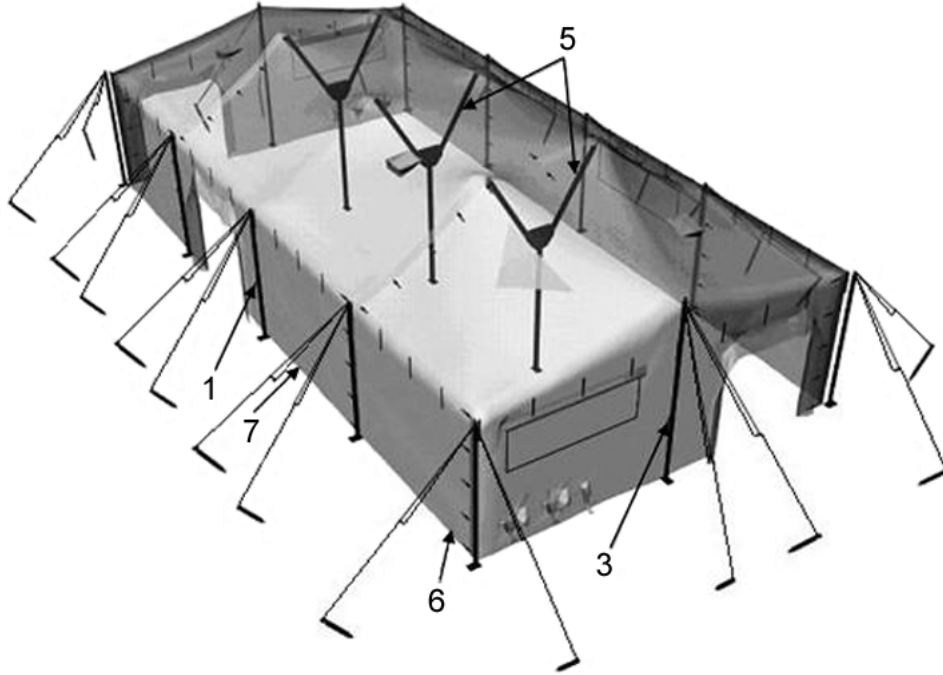
**Type II - The major components of the MGPTS are as follows:**

Tent Poles (Side) (**1**) are seven-foot long fixed-length aluminum poles. At the top of the side poles, there is a cap assembly (**2**). The base of the poles has a base plate with a stake tube. Guy ropes are attached to the cap assembly.

## LOCATION AND DESCRIPTION OF MAJOR COMPONENTS - continued

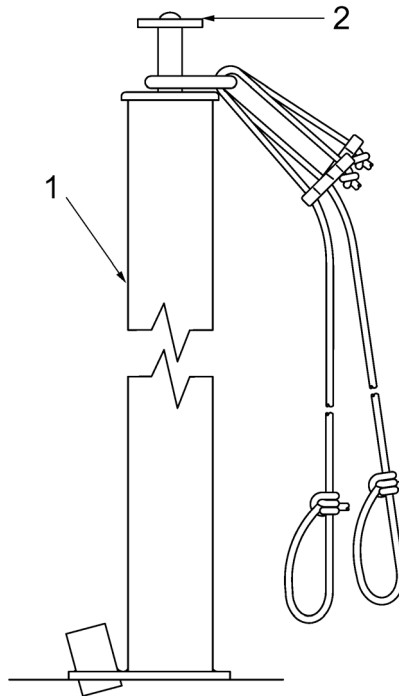

Pole, Tents (End) **(3)** are seven foot long aluminum poles extendable to nine feet. The end poles are extended by first pulling out a locking pin **(4)** on the upper leg assembly. Then pulling the upper leg assembly to the upper hole and pushing in the pin. At the top of the end poles there is a cap assembly, and the base of the poles have a stake tube.

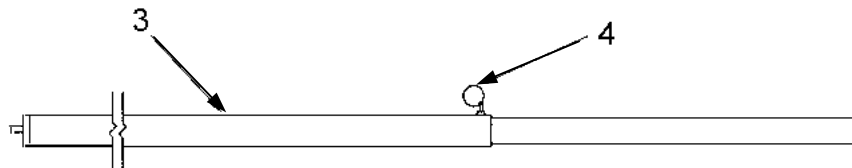

Arch Assemblies **(5)** are aluminum frame members. The fabric attach to the assemblies at the peaks and eaves. The leg of the Arch Assembly also has a stake tube. Guy ropes are attached to the top of the leg member.

End Sections **(6)** are made of polyester fabric that is white inside and green or tan on the outside. The roof, side and end walls are part of the end section. Attachment to other sections is made using grommets and becket lacing. Two flaps are buckled over the becket lacing. This makes the tent weather proof and light secure. Every end section has a door, window, ECU and electrical feed throughs.

**LOCATION AND DESCRIPTION OF MAJOR COMPONENTS - continued**

Mid Sections (7) are made of polyester fabric that is white inside and green or tan on the outside. The roof and sidewalls are part of the mid section. Attachments to other sections are made using grommets and becket lacing. Two flaps are buckled over the becket lacing. This creates a weather proof and light secure tent. Every mid section has a door and a window.

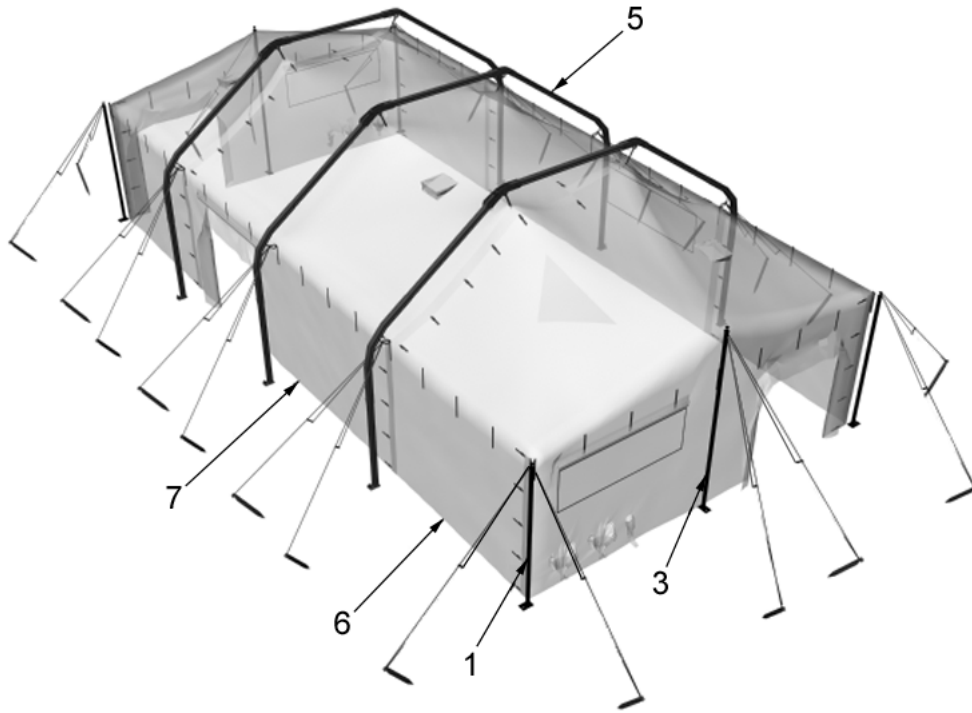

**LOCATION AND DESCRIPTION OF MAJOR COMPONENTS - continued****WARNING**

Do not use any type of non-vented heaters. The use of non-vented heaters will cause the accumulation of Carbon monoxide gas. Carbon monoxide gas is not visible and it has no smell. If symptoms such as headache, dizziness, fatigue, nausea, or irregular breathing occur, move affected personnel to fresh air. Failure to comply with this warning may result in personal injury or death.

All fuel burning heaters consume oxygen. Adequate ventilation must be maintained at all times. Keep roof vents clear of snow, ice or debris. Open doors, windows, flaps, hook and pile fastener wall closures as needed to introduce sufficient fresh air to replace oxygen consumed by heaters. If symptoms such as headache, dizziness, fatigue, nausea, or irregular breathing occur, move affected personnel to fresh air. Failure to comply with this warning may result in personal injury or death.

**End Section - The major components are as follows:**

Stovepipe Opening **(1)** allows passage for a 4-in. stovepipe. It has a protective cover that is secured with a hook and pile fastener.

Vent **(2)** is a passive vent type that involves porous foam, which is always open.

Door **(3)** is light secure with an integrated vestibule adapter. The vestibule adapter is compatible with a TEMPER vestibule.

Window **(4)** consists of a fixed screen section, clear plastic and fabric panels secured with hook and pile fasteners. The clear panel allows light in while providing weather security. The fabric panel covers the screen and plastic panels for weather and light security. The fabric and plastic panels can be rolled up and secured.

ECU Feed Throughs **(5)** are two environmental control feed-throughs provided near ground level. Heating or ventilation ducts can enter through these. The ECU feed-throughs can be closed using tie straps. This makes them weather proof and light secure.

Electrical Feed Through **(6)** is provided near the ground level for cables to enter the tent. The feed through can be closed using a tie strap. This makes it weather proof and light secure.



**LOCATION AND DESCRIPTION OF MAJOR COMPONENTS - continued**

Screen Walls (7) allow ventilation while keeping out insects. They can be rolled up to allow access.

Tie Tapes (8) are provided to secure rolled up fabric, screen, or clear plastic panels.

Mudskirts (9) are fabric sections attached to the bottom edge of sidewalls (10) and end sections (11). The mudskirts help keep moisture, debris, insects, and small animals out of tent. Sandbags may be placed on mudskirt to secure it.

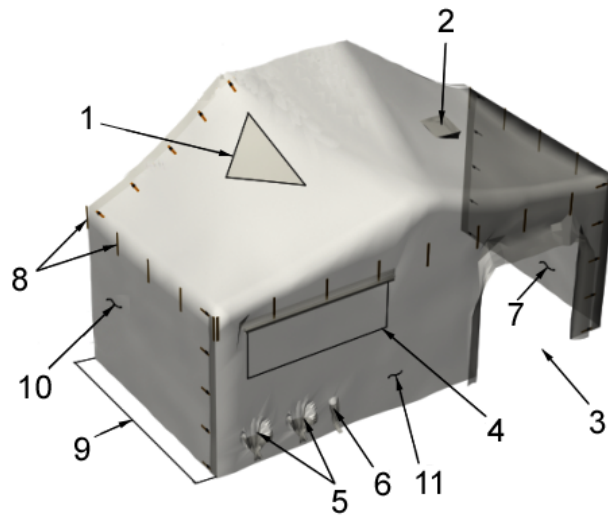

**DIFFERENCES BETWEEN MODELS**

The differences between the Type I and Type II for the three MGPTS sizes are the quantity of mid sections, Tent Poles (Side), Tent Poles (Y), and Arch Assemblies. The quantities of each required for the Type I MGPTS are listed in Table 1. The quantities of each required for the Type II MGPTS are listed in Table 2.

**Table 1. Quantity of Assemblies for the Type I MGPTS.**

Quantity			
	Small	Medium	Large
End Section	2	2	2
Mid Section	0	1	2
Tent Pole (Side)	6	10	14
Tent Pole (End)	2	2	2
Tent Pole (Y)	1	3	5
Arch Assembly	0	0	0

**Table 2. Quantity of Assemblies for the Type II MGPTS.**

Quantity			
	Small	Medium	Large
End Section	2	2	2
Mid Section	0	1	2
Tent Pole (Side)	4	4	4
Tent Pole (End)	2	2	2
Tent Pole (Y)	0	0	0
Arch Assembly	1	3	5

**EQUIPMENT DATA**

**Table 3. Type I MGPTS Component Weights.**

Items	Weight	Small Qty	Small Weight	Medium Qty	Medium Weight	Large Qty	Large Weight
End Section	131	2	262	2	262	2	262
Mid Section	169	0	0	1	169	2	338
Tent Pole (Y)	38	1	38	3	114	5	190
Tent Pole (Side)	8	6	48	10	80	14	112
Tent Pole (End)	15	2	30	2	30	2	30
Stakes and Bags			54		81		95
Actual Weight			<b>432</b>		<b>736</b>		<b>1027</b>

**Table 4. Type II MGPTS Component Weights.**

Items	Weight	Small Qty	Small Weight	Medium Qty	Medium Weight	Large Qty	Large Weight
End Section	131	2	262	2	262	2	262
Mid Section	169	0	0	1	169	2	338
Arch Assembly	85	1	85	3	255	5	425
Tent Pole (Side)	8	4	32	4	32	4	32
Tent Pole (End)	15	2	30	2	30	2	30
Stakes and Bags			54		81		95
Actual Weight			<b>463</b>		<b>829</b>		<b>1182</b>

**Table 5. Environmental Capabilities.**

Setup Temp.	-60 to 120 ° F
Setup Wind	25 mph max
Operate Temp.	-60 to 120 ° F
Operate Wind	55 mph steady state
	65 mph gusts

**Table 6. Packaged Volumes.**

End Section Bag	7.59 ft <sup>3</sup>
Mid Section Bag	15.04 ft <sup>3</sup>
End Poles Bag	5.43 ft <sup>3</sup>
Mid Poles Bag	3.48 ft <sup>3</sup>
Mid Frame Bag	17.36 ft <sup>3</sup>
End Frame Bag	17.36 ft <sup>3</sup>



---

**OPERATOR'S AND UNIT MAINTENANCE****MODULAR GENERAL PURPOSE TENT SYSTEM (MGPTS)****NSN 8340-01-456-3633, NSN 8340-01-456-3628, NSN 8340-01-456-3674****NSN 8340-01-516-6860, NSN 8340-01-516-6861, NSN 8340-01-516-6863****NSN 8340-01-491-1507, NSN 8340-01-491-1515, NSN 8340-01-491-1479****NSN 8340-01-516-6859, NSN 8340-01-516-6864, NSN 8340-01-516-6865****THEORY OF OPERATION**

---

**GENERAL INFORMATION**

The MGPTS is available as a Type I or a Type II system. It will serve as billeting or field service functions. All sizes of the MGPTS are 18 feet wide and 7 feet high at the top of the sidewall. The MGPTS can be extended in 18-ft increments by adding mid modules.

**FABRIC SECTION**

The current GP tents use fabric, which drapes over poles or attaches to arch frame members. The MGPTS uses the concept of a tensioned fabric roof to create a structure, which distributes wind, rain and snow loads from the fabric directly to the support system. Tensioned fabric structures distribute loads more efficiently with lighter support systems than comparable non-tensioned fabric tents. The use of interchangeable components between different size tents reduces logistics burdens and saves significant depot charges.

**END OF WORK PACKAGE**



**CHAPTER 2**

**OPERATOR INSTRUCTIONS**  
**FOR**  
**MODULAR GENERAL PURPOSE TENT SYSTEM (MGPTS)**





**OPERATOR'S AND UNIT MAINTENANCE  
MODULAR GENERAL PURPOSE TENT SYSTEM (MGPTS)  
NSN 8340-01-456-3633, NSN 8340-01-456-3628, NSN 8340-01-456-3674  
NSN 8340-01-491-1507, NSN 8340-01-491-1515, NSN 8340-01-491-1479  
TYPE I-OPERATION UNDER USUAL CONDITIONS**

This section applies to the Type I MGPTS only. If you are setting up a Type II MGPTS go to Work Package 0005 00 TYPE II-Operation Under Usual Conditions.

### SETUP TYPE I TENT SYSTEM

#### NOTE

These instructions are based on the medium MGPTS. For other tent sizes, the number of mid sections and poles will differ. Make modifications as required.

### SITTING REQUIREMENTS

Select an area to erect the tent. Ensure the area will be large enough for the tent and guy ropes that will be erected (see Table 1). The area should be clear of trees, rocks and debris. Choose a relatively flat area, the ground should not vary by more than 6 inches. A trench should be dug around the perimeter of the tent about 2-ft away from the edge. A drainage ditch should also be dug for water to exit the perimeter trench.

**Table 1. Area Setup Requirements.**

<b>Tent Model:</b>	<b>Length</b>	<b>Width</b>	<b>Height</b>
Small	34 ft	34 ft	12 ft
Medium	52 ft	34 ft	12 ft
Large	70 ft	34 ft	12 ft

### LAYOUT FABRIC SECTIONS

1. Identify each fabric section required. For the medium MGPTS, you will need two end fabric sections and one Mid Fabric Section.

## LAYOUT FABRIC SECTIONS - continued

**WARNING**

Fabric sections are heavy. Always lift with your legs not your back. Failure to observe this warning may result in back injury.

2. Transport each required fabric section into area where tent will be erected.
3. Unfold each mid fabric section **(1)** and end section **(2)** so that the inside (white side) is down and the green or tan side is up. Place these sections in center area where tent is to be setup.

**NOTE**

The mid fabric section **(1)** has lace and grommets on both ends. The end sections **(2)** have lace and grommets on one end.

4. Position end sections **(2)** on either side of the mid section **(1)** so that becket laces **(3)** align. Lay tent out flat. Fold side walls and end walls of mid **(1)** and end sections **(2)** under roof section so that only roof portions are exposed. This will allow easier access to the pole attachment points.

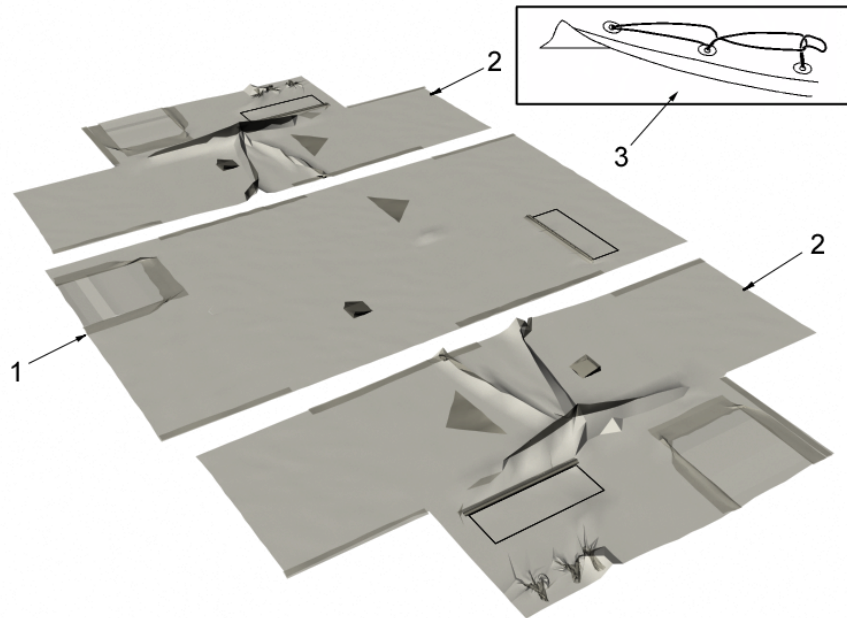

**CONNECT FABRIC SECTIONS**

Use the following procedures to connect becket lace between each end section and mid section:

**NOTE**

Split the four personnel into two person teams. Each team should perform steps 1-11 at the same time on opposite ends of the tent.

1. Find the two large snap hooks **(1)** at the center edge of end section and mid section roofs on underside of tent. Connect the snap hooks **(1)**.

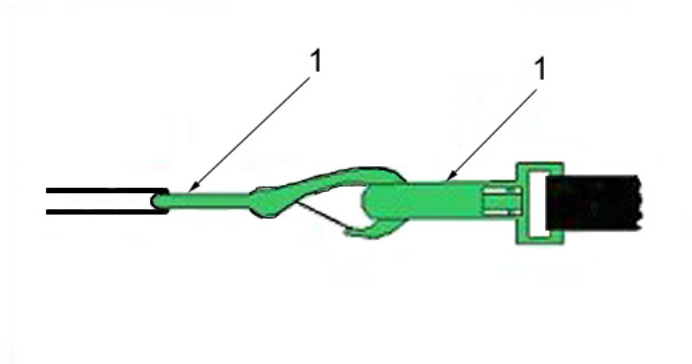

2. Find the becket lace **(2)** at one end of roof. You may start at either end of roof.

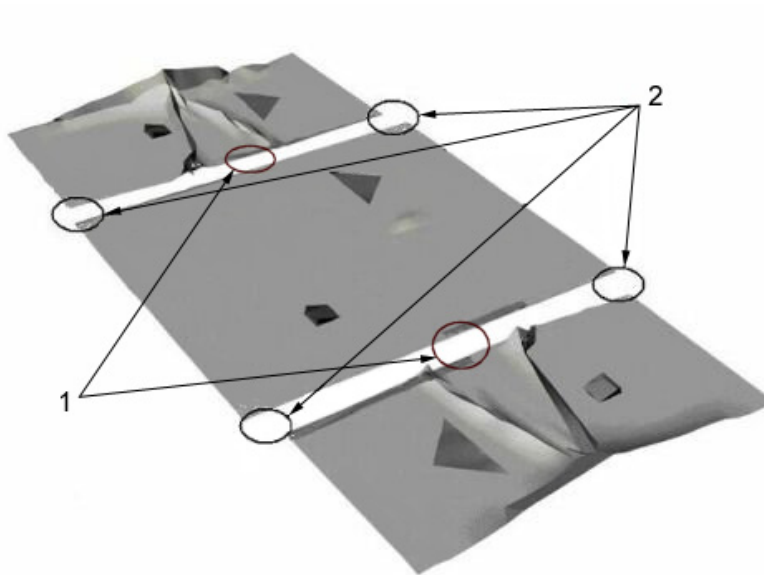

**CONNECT FABRIC SECTIONS - continued**

3. Lace the fabric sections together by using the following instructions. Insert the first rope loop (1) on one roof section through the first small grommet (2) of the adjoining roof section (3).

**NOTE**

Loops always enter the white side of the fabric and exit the green or tan side. All loops should be pulled tight.

4. Insert the second loop (4) through the second grommet (5) and through the first loop (1). Insert the third loop (6) through the third grommet (7) and the second loop (4). Repeat this pattern until reaching the other side of the tent.

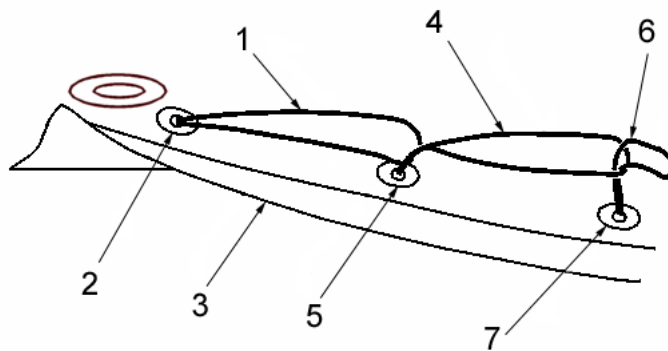

5. At the end, tie off last becket lace by using the following instructions: Insert the next-to-last becket lace (8) through loop of last becket lace (9). Pull the next-to-last becket lace (8) back towards the ridge and tie off with half-hitch knot.

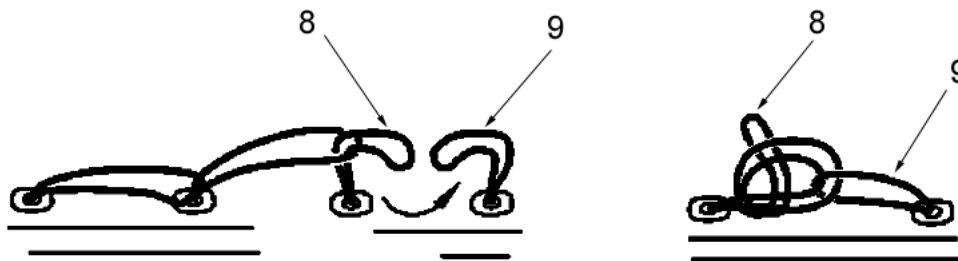

6. Pull 1-1/2-in. web pole loop (1) through grommet (2) at perimeter.
7. Flaps are identical. It does not matter which is on top or bottom.

**CONNECT FABRIC SECTIONS - continued**

8. Fold one flap (5) over becket lace.
9. Feed 1-1/2-in. web pole loop (1) at eave through slit in flap (5).
10. Fold other flap (6) along the length of the tent over the first flap (5) and feed 1-1/2-in. web pole loop (1) through slit in outer flap (6). Then, connect buckles (7) along the flap.

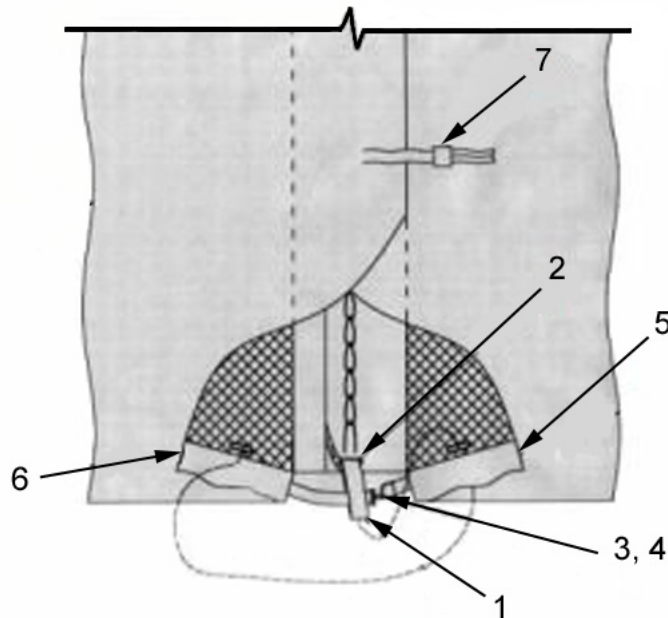

11. Connect D-ring (3) on  $\frac{3}{4}$ -inch strap at the eave to adjoining section's snap hook (4).

**CONNECT FABRIC SECTIONS - continued****NOTE**

Make sure d-ring strap is below 1-1/2-in. web pole loop.

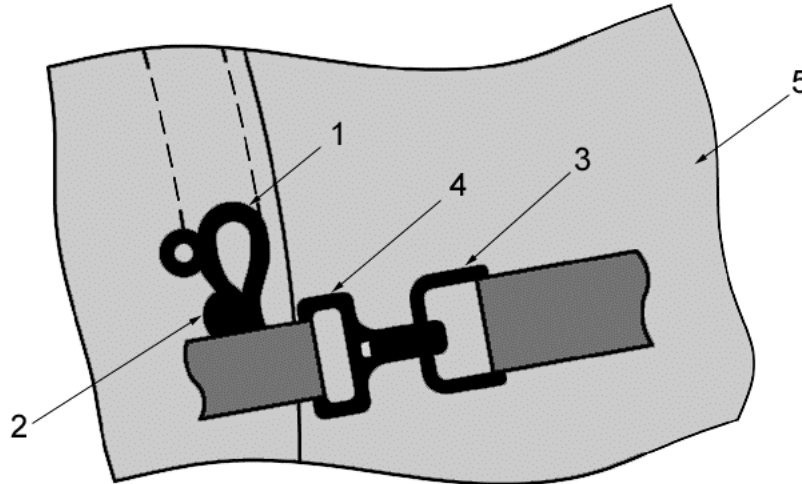

12. With one person at each corner of the tent, stretch fabric tight to remove slack.

**SETTING UP TENT POLES****NOTE**

Stay in your two person teams. Each team should perform steps one through sixteen on opposite ends of the tent.

**NOTE**

Side poles are not adjustable. For the medium type I MGPTS all ten side poles will be used.

1. Locate side poles (1).
2. Make sure each side pole (1) has two guy ropes (2) attached to cap assembly (3).
3. Place one side pole (1) at each corner of tent (4), and at each 1-1/2-in. web loop along the side eave. Place cap assembly spindle (5) through 1-1/2-in. web loop (6) at eave.

## SETTING UP TENT POLES - continued

**NOTE**

At each corner of the tent make sure web loops are pulled through slit in fabric shingle.

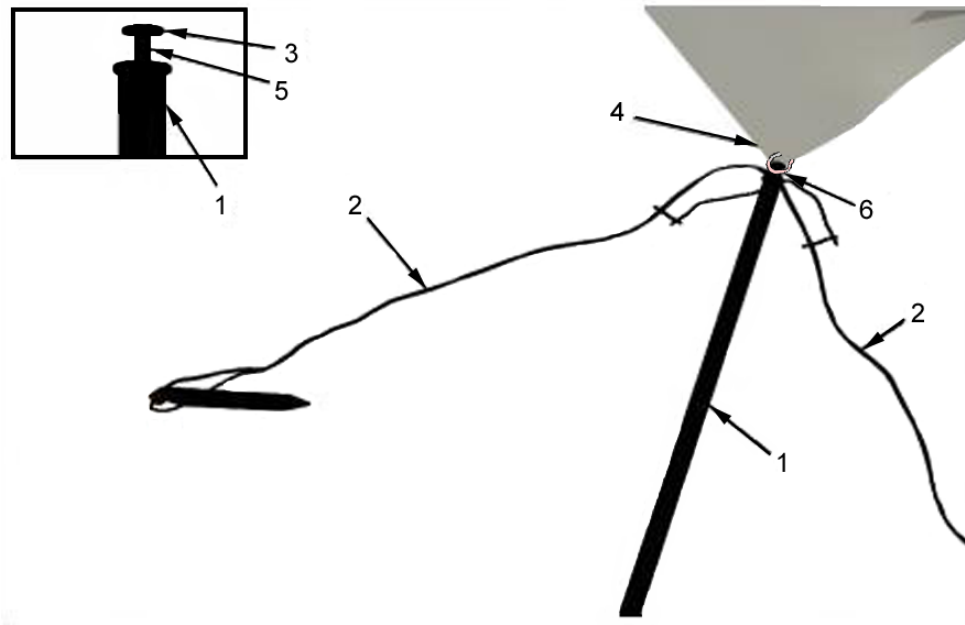

4. Find two end poles (1). Adjust them to maximum height by pulling pin (2) out at bottom of pole. Push pin (2) back in when holes are aligned. Place cap assembly spindle (3) through 1-1/2-in. web loop at middle of each tent end section's roof edge.

**SETTING UP TENT POLES - continued**

**NOTE**

Ensure the flat side of the pole is on the ground with the pin facing up, so that guy ropes slide freely through ring at top.

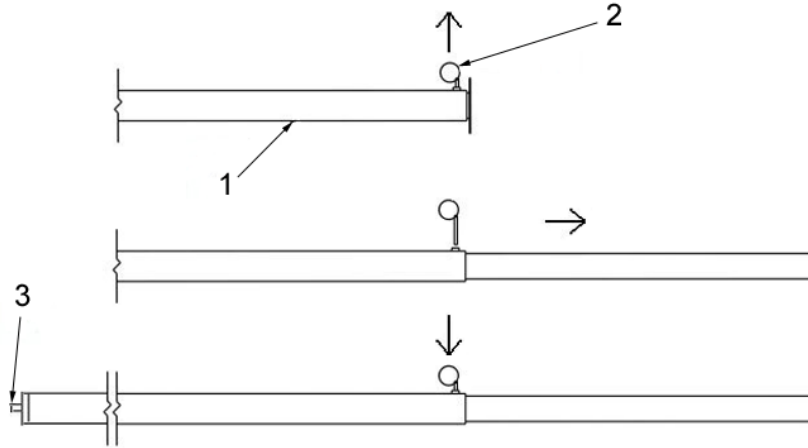

5. Corner poles should be aligned with fabric seam (1) in end section roof. Stakes may then be placed 6-ft out along pole and 1-ft on either side of pole.
6. Follow staking diagram below. Drive in the 36-in. wood stakes at all points indicated on diagram. It is important to have a stake at each of the marked points.

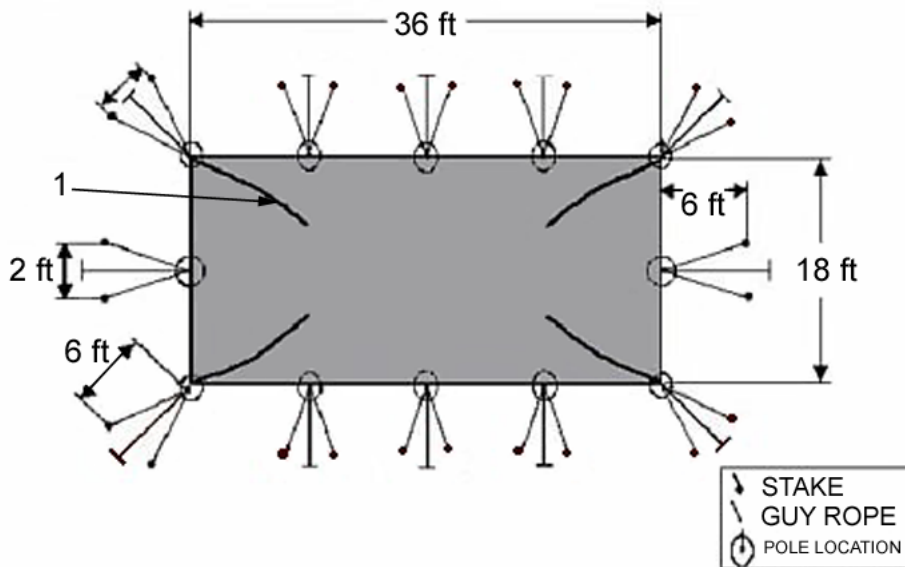



**SETTING UP TENT POLES - continued**

7. Drive stakes 6-ft out from tent edge and angle stake slightly away from tent. Wood stakes (1) should be driven in until only 6-in. extend above the ground.

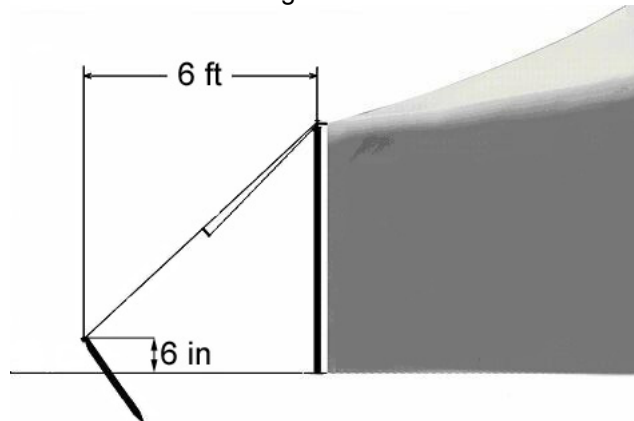

8. Place guy ropes (1) over wood stakes (2), making sure that ropes are not twisted or crossed. Loosen rope adjustment to leave plenty of slack. This will make it easier to stand poles up. Connect guy ropes at all pole locations.
9. Start at one corner. One person lifts corner roof fabric (3) while the second person grasps pole (4) and rotates bottom of pole under roof fabric (3) and stands pole up so that bottom of pole is angled in toward center of tent. Tighten guy ropes (1), by sliding tensioner (5), to keep poles from falling.
10. Repeat step nine for other two corners.

**NOTE**

Guy ropes must be snug to keep poles from falling.

11. Stand side poles up along each side of the tent. One person lifts roof fabric (4). Other person grasps pole (1), rotates bottom of pole under roof fabric (4) and stands pole up so that bottom of pole is angled slightly in towards center of tent. Tighten guy ropes (2) to keep poles from falling.
12. Repeat step eleven for all side poles.

## SETTING UP TENT POLES - continued

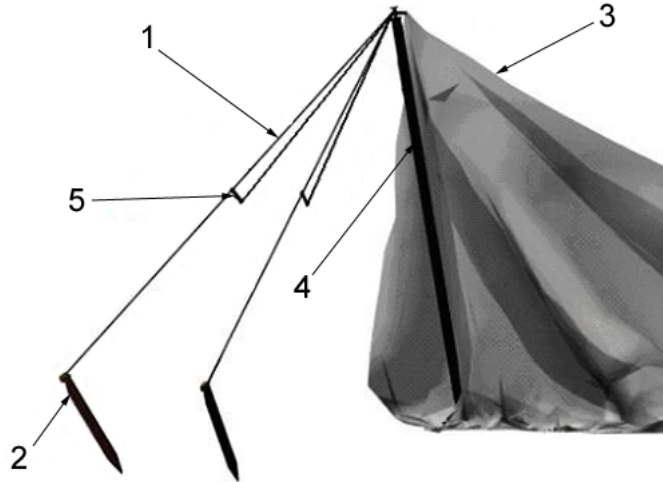

13. Roll up one 9-ft long sidewall of tent. Use tie straps at eave to secure the rolled up section.

**NOTE**

If liner is required, install the liner before raising the Y-Poles and end poles (see WP 0007 00, Installing liner in type I tent system).

**NOTE**

If lights are authorized, install light assemblies before raising Y-Poles and end poles and after the liner if authorized (see page 0004 00-14, Installing light assemblies).

**NOTE**

If plenum is required, install the plenum before raising the Y-Poles and end poles and after the liner (if installed) and lights (if installed). Refer to WP 0008 00 for installation instructions.

14. Stand end pole up. One person lifts roof fabric (4). Other person grasps pole, rotates bottom of pole under roof fabric (4) and stands pole up so that bottom of pole is angled slightly in towards center of tent. Place flat side of end pole towards tent so that guy ropes slide freely through ring at top. Tighten guy ropes (2) to keep pole from falling.

## SETTING UP TENT POLES - continued

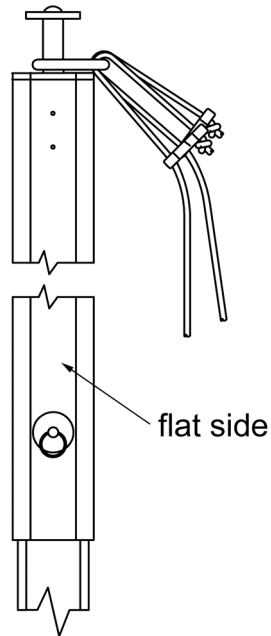

15. At other end of tent, stand end pole up. One person lifts roof fabric **(4)**. Other person grasps pole, rotates bottom of pole under roof fabric **(4)** and stands pole up so that bottom of pole is angled slightly in towards center of tent. Place flat side of end pole towards tent so that guy ropes slide freely through ring at top. Tighten guy ropes **(2)** to keep pole from falling.

**RAISING TYPE I TENT SYSTEM****WARNING**

Use care to ensure fingers or other body parts are not caught in Y-Pole hinge point. Body parts may get pinched or caught. Failure to comply may result in serious injury to personnel.

1. Locate Y-Poles **(1)**. Identify the peak fittings **(2)** which are metal tubes attached to flat metal plates located on the inside of the roof fabric. Using two people carry each Y-Pole into tent through the sidewall opening. Do not open y-arms while carrying Y-Pole. Position Y-Poles **(1)** on ground. Unfold y-arms. Tops of y-arms should be located under peak fittings **(2)** on bottom side of tent.

**NOTE**

If lights are authorized, place the y-arms between the lights.

**NOTE**

If plenum is authorized, place plenum between the y-arms.

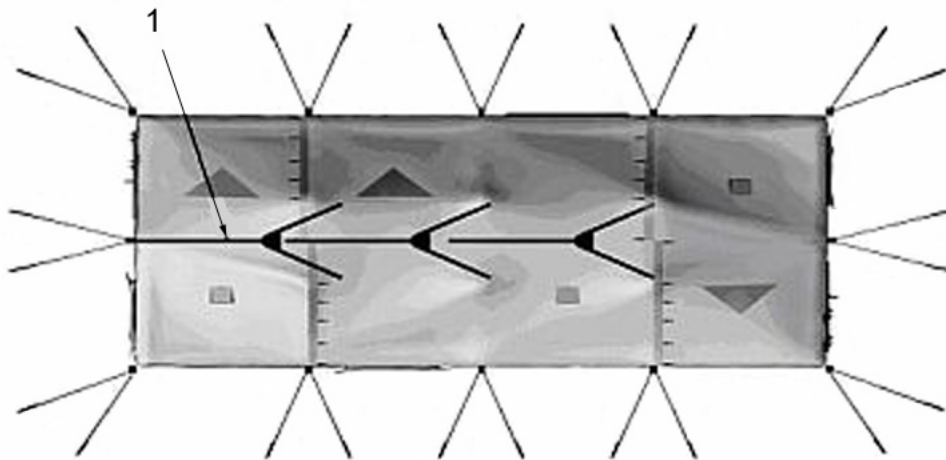

2. Raise Y-Pole. With one person holding each y-arm **(3)** and the third person grasping the pole body, place peak fittings **(2)** all the way into ends of the y-arms **(3)**.

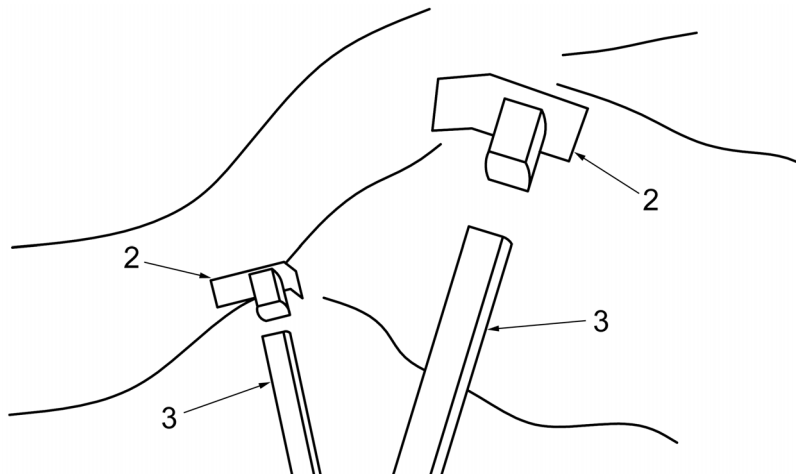
**RAISING TYPE I TENT SYSTEM - continued****WARNING**

Use care to ensure fingers or other body parts are not pinched while inserting y-arms into peak fittings. Body parts may get pinched or caught. Failure to comply may result in serious injury to personnel.

3. Once both peak fittings **(2)** are inserted into y-arms **(3)**, lift Y-Pole **(1)** to a vertical position.
4. Repeat this procedure for all Y-Poles.
5. From one end, view Y-Poles and make sure they are aligned.

## TENSIONING TYPE I TENT SYSTEM

1. Corners should be tensioned first. Tension one corner at a time.
  - a. Start at a corner. The first person should position himself between the stakes (1) and pole (2). The same person should grasp pole (2) at top, below cap assembly with both hands. This person rocks back towards stake (1) keeping base of the pole in place. Second person tightens guy ropes (3), by sliding tensioner (4) down b (3). Both people grasp pole and straighten pole (2) to a vertical position.

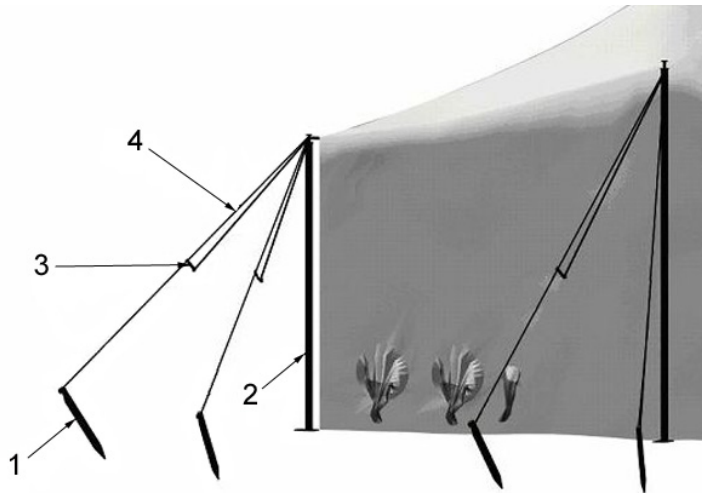

- b. Repeat procedure on other three corners.
- c. Repeat this procedure on side poles.
- d. Repeat this procedure for the two end poles until entire tent is tensioned.

### NOTE

Sidewall can be configured in three different ways: all walls down, cloth walls rolled up with screen walls down or both cloth walls and screen walls rolled up.

2. Secure vertical fabric sections. For both attachment points of wind straps on sidewalls, pull straps through slit on opposing wall section.
  - a. Starting at the top of the vertical fabric sections attach them together with the fasteners.
  - b. Pull both sets of strap ends of wind straps through the corresponding slit on outer flap.
3. Starting at top of vertical fabric sections, connect the four buckles on outer flap.
4. Wrap both wind straps around pole and tie straps with an appropriate knot so that the sidewalls hang vertically.

**TENSIONING TYPE I TENT SYSTEM - continued**

5. Attach hook and pile fasteners on rain flaps to sidewall flap for blackout integrity.
6. Repeat these procedures for all pole locations.

**NOTE**

Tweak Y-Poles after completion of tensioning.

7. Staking sidewalls and poles:
  - a. Locate the 12-in. polycarbonate stakes.
  - b. Locate the rope loop facing out at the base of the Side Walls.
  - c. Insert finger into rope loop **(1)**, twist rope loop to form a figure 8. Place the two newly created loops around finger. Insert stake into both loops and drive stake into ground.

**NOTE**

Do not drive 12-in. stakes all the way into the ground; leave them about two inches out. This will make it easier to remove the stakes.

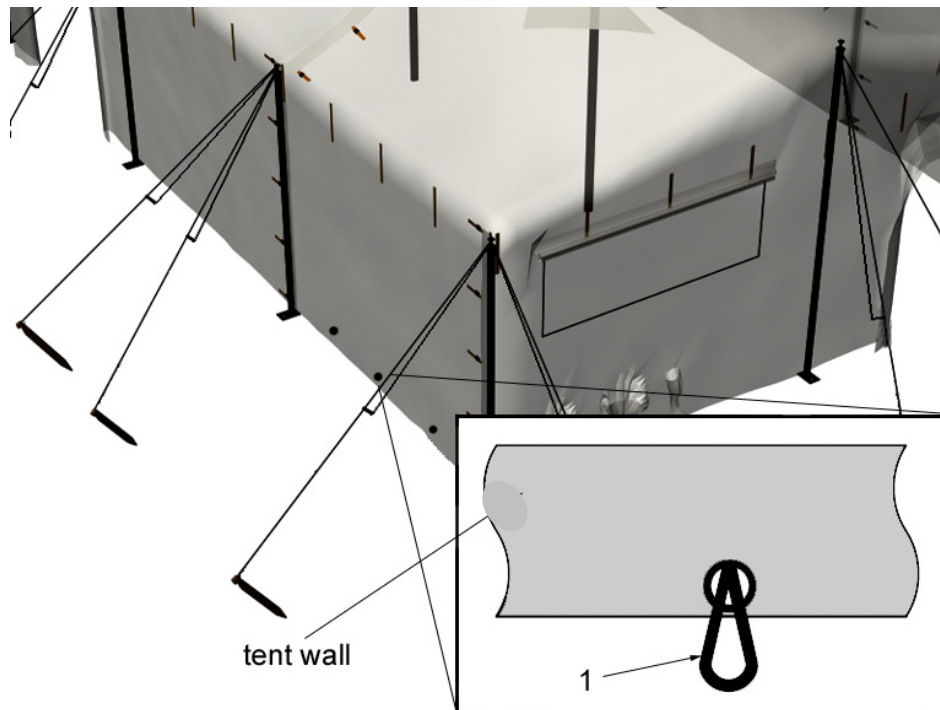

- d. Drive a stake through the stake tube **(2)** at base of pole and the rope loop **(1)**.

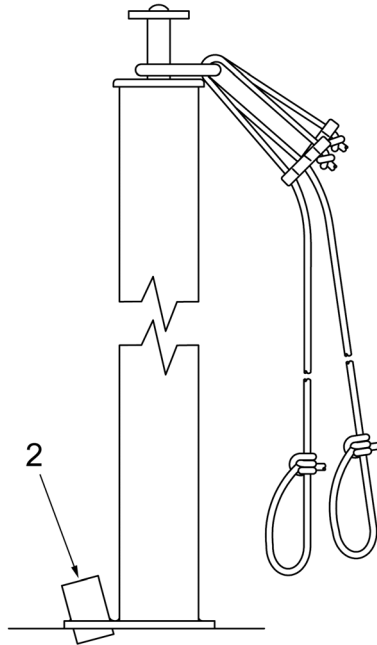
**TENSIONING TYPE I TENT SYSTEM - continued**

- e. Repeat this procedure for all rope loops and stake tubes.

**NOTE**

If floor is authorized, install the floor now. See work package 0006 00 for setup instructions.

**NOTE**

If liner is authorized, install the liner now. See work package 0007 00 for setup instructions.



**INSTALLING LIGHT ASSEMBLIES**

Use these procedures to complete installation of the light hangers.

**WARNING**

Do not connect plugs to power source before installing light assemblies.

**NOTE**

When installing light assemblies, lower the Y-Poles and end poles if they are installed.

1. Inside light set case (1), locate light support strap assembly (2).

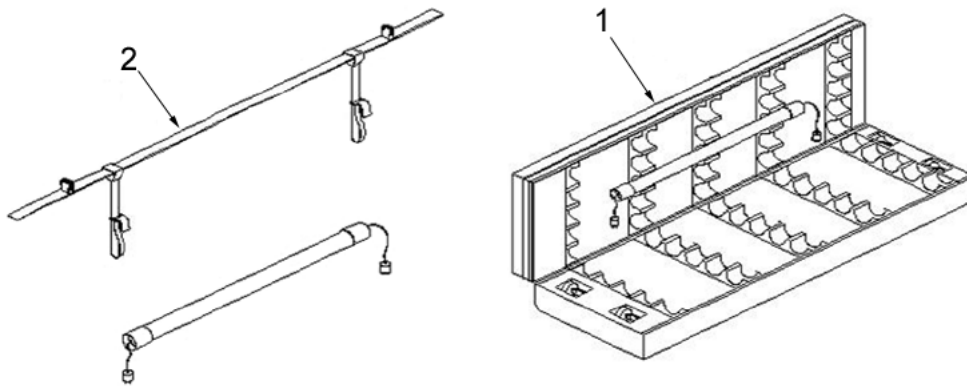
**WARNING**

Light set case is heavy. Two persons are required to lift light set case to avoid injury to personnel. Failure to comply may result in serious injury.

2. Carry lights and light support strap assembly (2) into tent.

**INSTALLING LIGHT ASSEMBLIES - continued**

3. Locate light hanger attached on inside of fabric near peak fitting.

**NOTE**

To prevent damage, leave lights in case until ready to install. Make sure male plug end is toward external power source.

4. Attach the light support strap to the light in the following manner:
  - a. Wrap strap loops around each end of light on inside of rubber end caps.
  - b. Pull strap up through d-ring and press down to engage hook and pile fasteners.
  - c. Orientate plug properly, so that it can be mated to next light, ensuring reflecting surface faces up and lamp faces down.
  - d. Repeat step (a) through (c) for additional lights (if needed).
5. Attach light support straps to light hangers.
6. Repeat this procedure for all light assemblies.
7. Connect lights.

**CAUTION**

Do not connect more than 12 lights together. Damage to electrical circuit may result.

**NOTE**

If Y-Poles and end poles were installed before lights, raise them into position again now.

**NOTE**

If plenum is authorized, install the plenum now. See work package 0008 00 for instructions.

**INSTALL VESTIBULE**

When authorized, vestibule may be used as a passageway or blackout entryway. It may be connected to an end or mid section doorway. Erect the vestibule as follows for all configurations.

**INSTALL VESTIBULE - continued**

1. Remove the stakes that block the path of the vestibule and re-stake them in a position out of the vestibule's way.
2. Re-tension the relocated stake's guy ropes.
3. Locate and unroll vestibule adapter at tent door.
4. Locate, layout and assemble vestibule arch assembly **(1)** components. The vestibule arch assembly **(1)** comprises of a vestibule header **(2)** and two legs **(3)**.

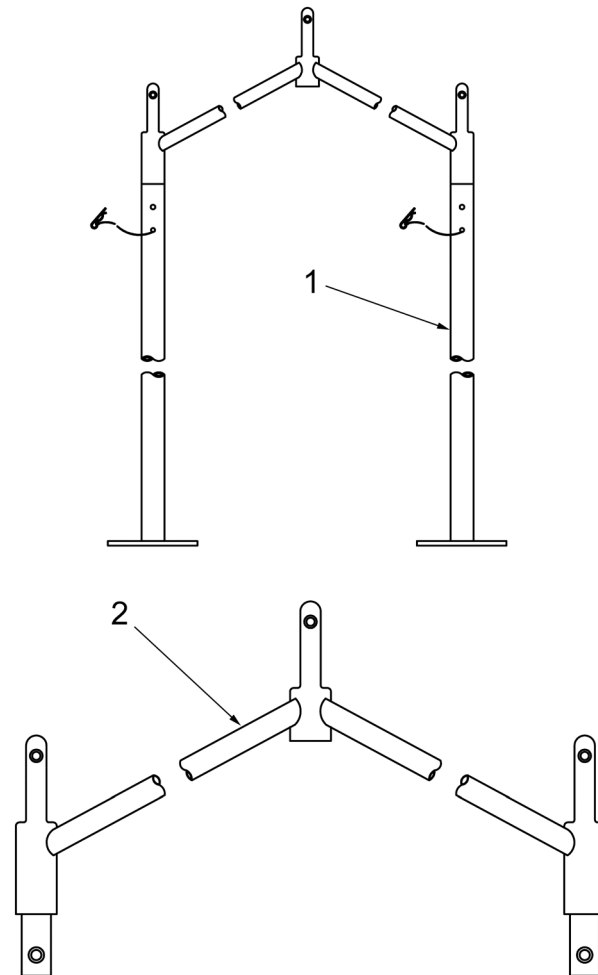

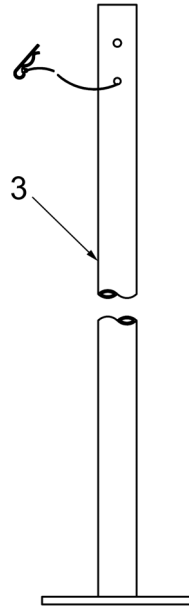
**INSTALL VESTIBULE - continued****CAUTION**

Position hitch clip pin (the curved part) towards inside of vestibule arch assembly **(1)**. Vestibule fabric may tear if (the curved part) hitch clip end is pushing against the fabric.

5. Open tent door and place all vestibule arch assemblies **(1)** inside.
6. Starting at the vestibule peak, becket lace the vestibule fabric to the adapter through grommets **(4)** lacing towards the eave, tie off with half hitch knot. Becket lace the vestibule fabric to the adapter through grommets lacing towards the ground, tie off with half hitch knot. Repeat this procedure for the other side of the vestibule.

INSTALL VESTIBULE - continued

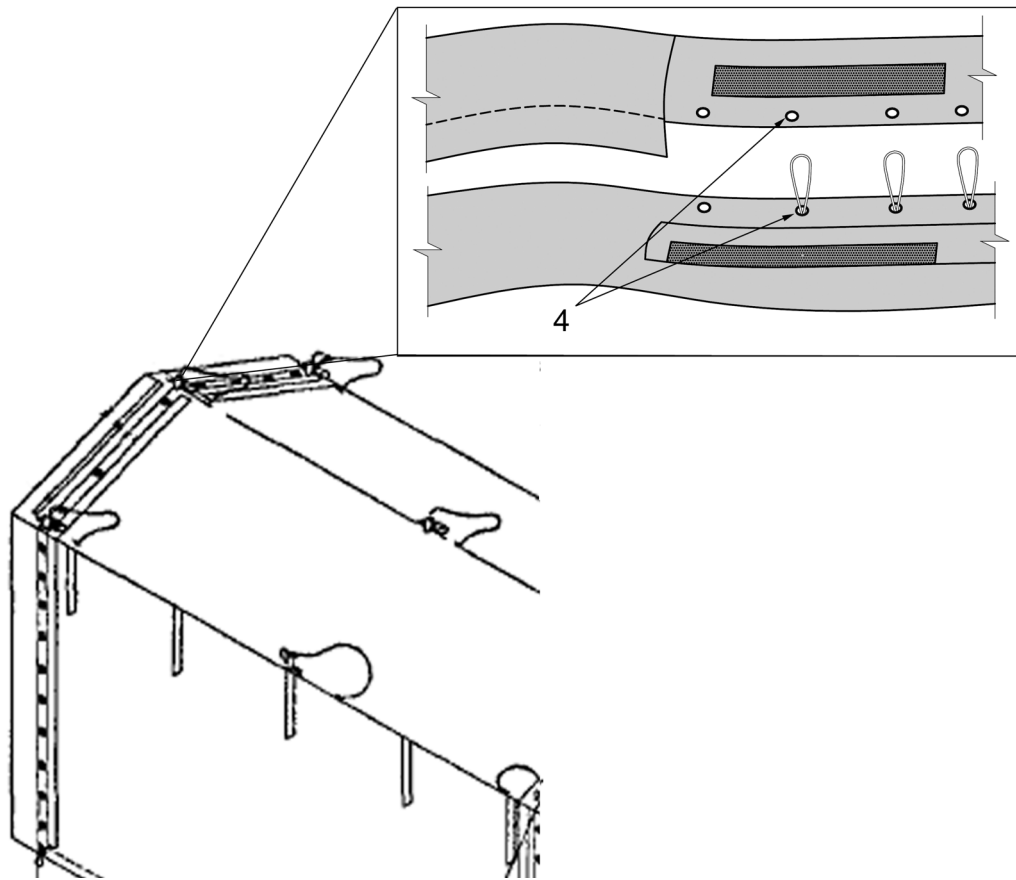

7. Align vestibule spindle grommet (5) with vestibule adapter spindle grommet (5).

## INSTALL VESTIBULE - continued

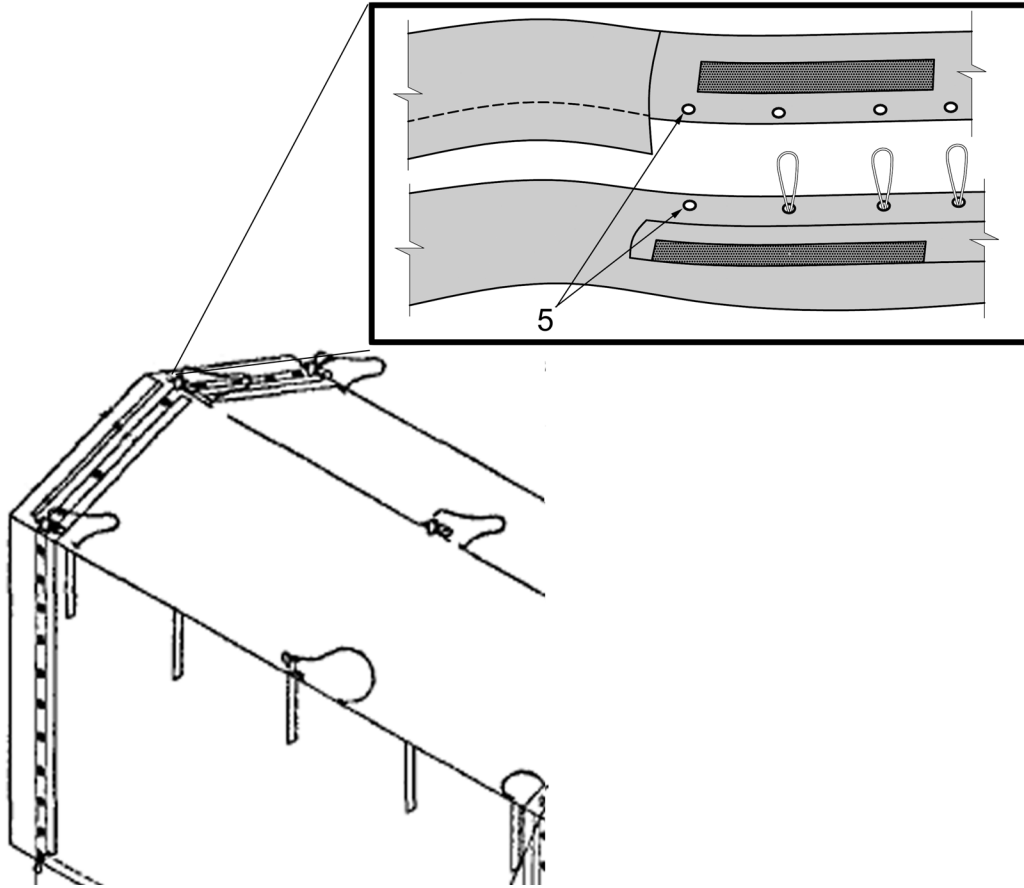

8. Insert vestibule frame spindles in vestibule spindle grommet and vestibule adapter grommet. Secure ridge grommets with hitch clip pins.
9. Raise vestibule arch assembly **(1)** into a vertical position.
10. Repeat steps eight and nine for the remaining vestibule arch assemblies.
11. Extend arches and fabric.
12. Install two guy ropes under hitch clip pins on eave spindles of last vestibule arch.
13. Place 24-in. wooden stakes about 6-ft out, facing towards vestibule door.
14. Tie guy ropes to stakes and tighten.
15. Secure vestibule fabric to vestibule arch with tie tapes.

---

## **OPERATING PROCEDURES**

### **Operate Doors**

Use following procedures to operate the doors on the MGPTS:

Door is opened and closed using hook and pile fasteners. The inner door can be rolled up (towards the inside to prevent rain from being trapped within the folds) and secured with straps at the top.

Outside the tent there is a sliding door. The sliding door can be secured in the open position with attached straps, and secured in the closed position with buckles.

### **Operate Windows**

Use following procedures to operate tent windows. Windows can be opened for ventilation or closed due to inclement weather. Windows have three panels.

The fabric cover and clear windows are closed by hook and pile fasteners.

The fabric cover and clear window can each be held open with tie tapes.

Each layer must be rolled up towards the inside to prevent rain from being trapped within the folds.

To fully close the fabric cover, the clear window must first be unrolled and secured.

---

**OPERATING PROCEDURES - continued****Operate Roof Vents**

---

**WARNING**

---

Do not use any type of non-vented heaters. The use of non-vented heaters will cause the accumulation of carbon monoxide gas. Carbon monoxide gas is not visible and it has no smell. If symptoms such as headache, dizziness, fatigue, nausea, or irregular breathing occur, move affected personnel to fresh air. Failure to comply with this warning may result in personal injury or death.

All fuel burning heaters consume oxygen. Adequate ventilation must be maintained at all times. Keep roof vents clear of snow, ice, or debris. Open doors, windows, flaps, hook and pile fastener wall closures as needed to introduce sufficient fresh air to replace oxygen consumed by heaters. If symptoms such as headache, dizziness, fatigue, nausea, or irregular breathing occur, move affected personnel to fresh air. Failure to comply with this warning may result in serious injury or death to personnel.

**NOTE**

Roof vent is made from foam and is always open, no operation is required.

**Operate Fabric Walls**

Outside walls can be rolled up (towards the inside to prevent rain from being trapped within the folds) and tied off for ventilation if needed.

**Operate Stovepipe Openings**

The stovepipe vent is opened and closed by pulling the cord **(1)** attached to the vent cover **(2)**. To open, pull the cord **(1)** to the opposite side of the tent. To close, pull cord to the near side. The vent cover will secure itself when it is closed.

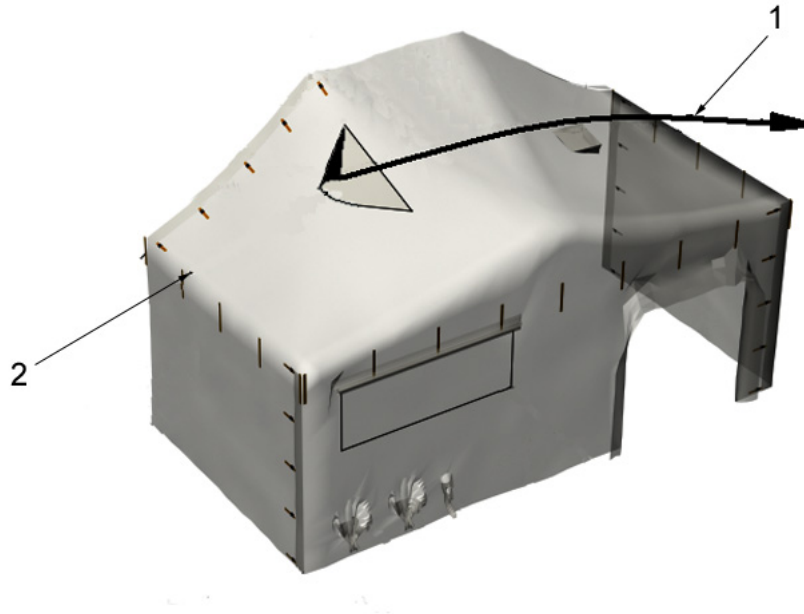

**OPERATING PROCEDURES - continued****REMOVE VESTIBULE**

Use following procedures to remove the vestibule:

1. Remove the 12-in. pins in base plates of vestibule arch assemblies (if installed).
2. Loosen guy lines to stakes.
3. Remove 24-in. wooden stakes.
4. On last vestibule arch remove two guy ropes on eave spindles.
5. On tent door, untie becket lace from ridge to eave, unseal weather flap, remove the remaining hitch clip pins and complete becket unlacing.
6. Remove vestibule arch spindles from grommets.
7. Remove vestibule arch and fabric from adapter.
8. Repeat procedures one through seven for remaining vestibule(s).

**REMOVE LIGHT ASSEMBLIES**

Use the following procedures to remove the light support strap assemblies.



---

**WARNING**

---

Lethal voltage is present when light set is connected to a power source. Disconnect power source prior to removing light assemblies. Failure to do so may cause serious injury or death.

1. Locate light case.
2. Turn off light and disconnect from power source. Un-mate plugs from all lights.

**NOTE**

Y-Poles and end poles must be lowered before striking lights and light plugs must be unmated to prevent damage to lights.

3. Pull light support strap down through D-ring and disengage hook and pile fasteners.
4. Unwrap light support strap around each end of light.
5. Place light in light case.
6. Repeat steps one through five for removal of additional lights.
7. Remove light support strap assembly.
8. Place light support strap assembly in light case.

---

**STRIKING TYPE I TENT SYSTEM****NOTE**

If the MGPTS is equipped with a plenum, remove the plenum first before striking tent. Refer to WP 0008 00 for instructions.

**NOTE**

If the MGPTS is equipped with a lights, remove the lights before striking tent. Refer to "Remove Light Assemblies" in this work package for instructions.

**NOTE**

If the MGPTS is equipped with a liner, remove the liner before striking tent. Refer to WP 0007 00 for instructions.

**NOTE**

If the MGPTS is equipped with a floor, remove the floor before striking tent. Refer to WP 0006 00 for instructions.

**Strike the Tent**

1. Make sure fabric is dry before disassembly.
2. Unfasten buckles.
  - a. Unfasten buckles on sidewalls and untie wind straps from poles.
  - b. Detach hook and pile fasteners at sidewall connections, pulling straps through slits. Repeat this procedure until all of side and corner wall connections are detached.
3. Loosen guy ropes to reduce tension on fabric. Do not remove guy ropes.
4. Remove stakes from rope loops and stake tubes on poles around skirt of tent.

**STRIKING TYPE I TENT SYSTEM - continued**

5. Remove Y-Poles.
  - a. Go inside of tent, using three persons, remove Y-Poles from peak fittings one at a time.
  - b. Position Y-Pole on ground then fold arms down.



---

**WARNING**

---

While folding down Y-Pole arms caution must be used to avoid pinching fingers.

- c. Move Y-Poles to outside of tent for placement in pole bag.
6. Drop poles.
  - a. Loosen guy ropes for poles.
  - b. Lower poles to the ground in the following order: end, side and corner poles.
  - c. Remove poles from 1-1/2-in. web loop.

**NOTE**

Ensure Y-Poles are stored with the pins facing up to prevent tearing or ripping bag.

- d. Move poles to location for placement in pole bags.

**STRIKING TYPE I TENT SYSTEM - continued****NOTE**

Use two-man teams.

7. Separate fabric sections.
  - a. Lift flap and remove 1 1/2-in. web loop at the becket lace between each end and mid section.
  - b. Unhook d-ring from snap hook at eave joint sections **(1)**.
  - c. Unhook buckles on roof and unfold flaps.
  - d. Unlace becket lace.
  - e. Remove becket lace from grommets.
  - f. Unhook snap hook **(2)** at the center edge of the end and mid section.

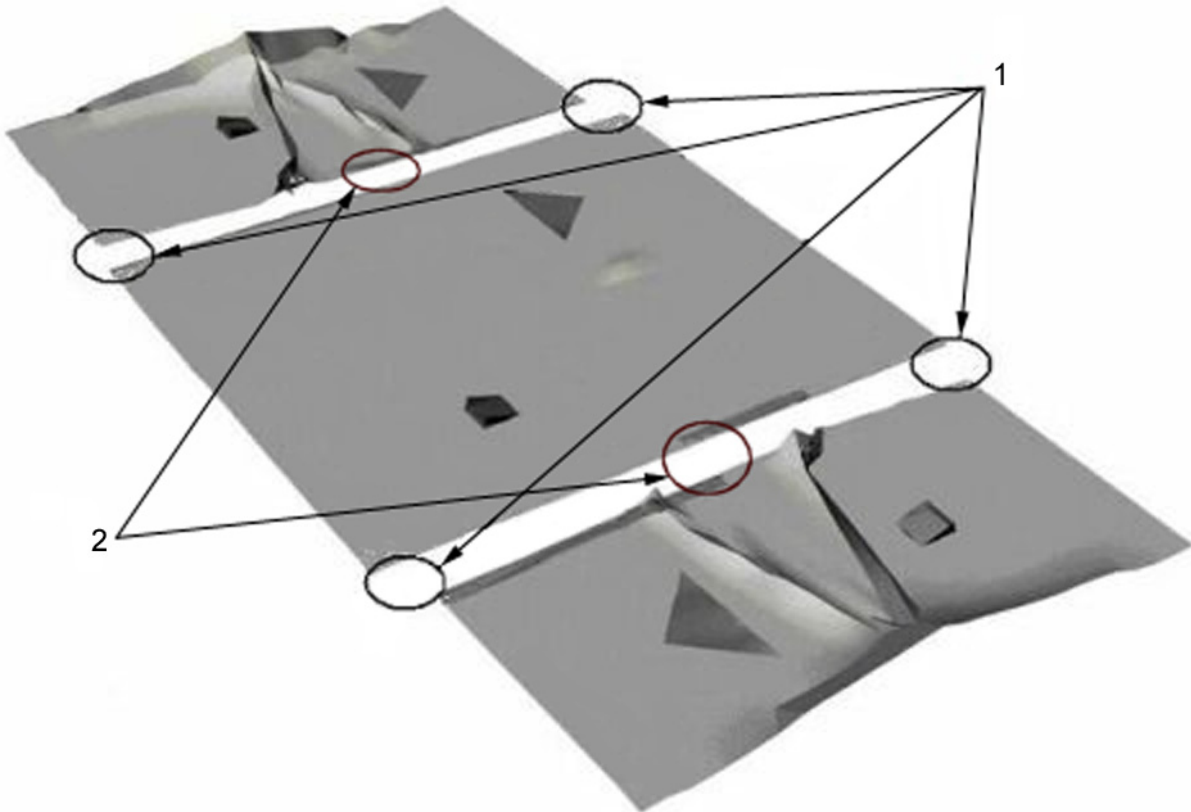

- g. Move fabric sections for folding and placement in transport bags.

**FOLD FABRIC SECTION**

The following section will demonstrate tent packing procedures for the MGPTS.

1. The end sections are to be folded as follows:
  - a. Start with the end fabric section spread out flat, with the green or tan side facing upward.
  - b. Fold each end section wall over the end section roof as shown.
  - c. Fold end wall over end section roof.
  - d. Fold edges of roof inward on themselves, so that both meet at the center of the end section roof.
  - e. Fold fabric in half, so that the entire width of the folded section is less than 5 ft.
  - f. Roll fabric as illustrated.

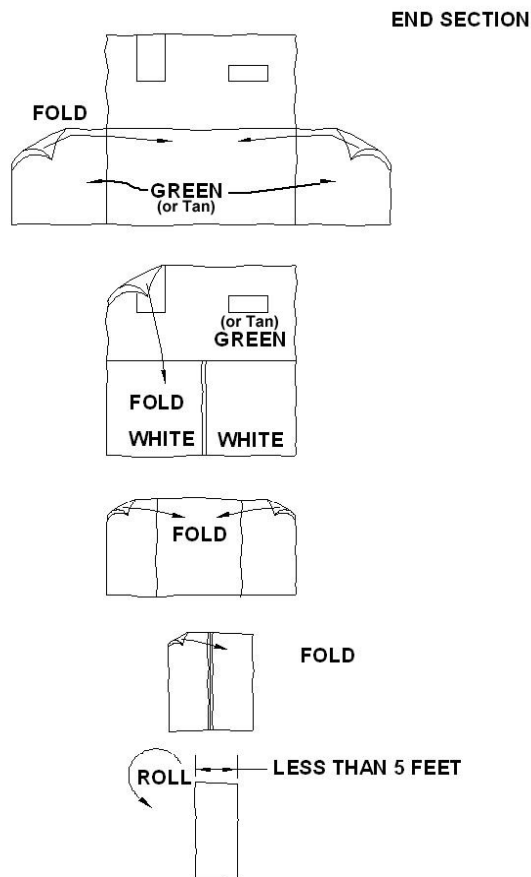

**FOLD FABRIC SECTION - continued**

2. The mid sections (if used) are to be folded as follows.
  - a. Start with the mid section spread out with the green or tan side up, as shown below.
  - b. Fold mid section walls over mid section roof so that the two outer edges of the fabric meet at the middle of the roof. Fold walls with the windows and door onto roof cloth, up to the perimeter edge, where wall meets roof cloth.
  - c. Fold the mid section fabric in on itself as illustrated, so that the edges meet at the middle of the roof.
  - d. Fold the edges of the mid section one final time, so that the width of the folded section is less than five ft.
  - e. Roll fabric as illustrated.

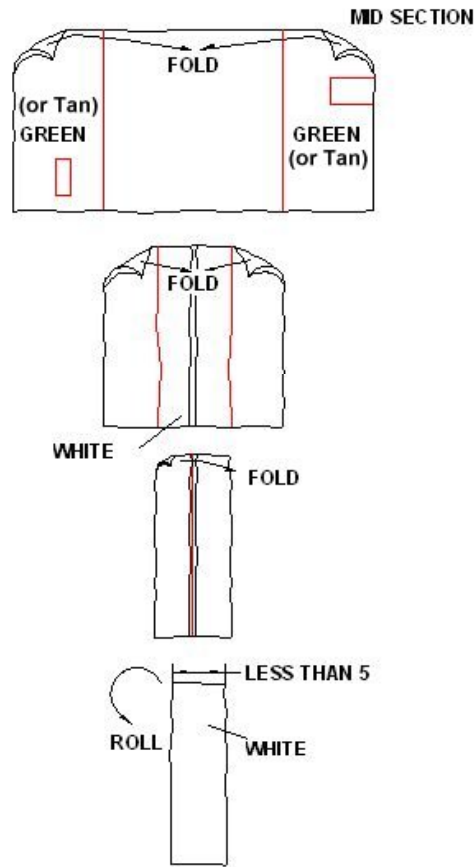

**FOLD FABRIC SECTION - continued**

3. Ensure that all elements of the MGPTS are inspected as specified in the Preventive Maintenance Checks and Services (PMCS), WP 0011 00.
4. Check all poles to ensure they are folded and locked in their original shipped condition.
  - a. End poles should be retracted and locked at their original 7-foot height.
  - b. Side and end poles should have guy ropes and all original equipment attached as specified in the RPSTL WP 0027 00 and WP 0028 00.
  - c. Y-poles should have the y-arms folded down to their original shipped condition.
5. Place tent contents in properly labeled bags.

The folded End Section fabric should be packed in the bag labeled "End Fabric Module."  
For the Type I MGPTS, the bag labeled "End Poles," should have the following contents stored in it:

- 1 Tent Pole (Y) Assembly
- 2 Tent Pole (End) Assemblies
- 6 Tent Pole (Side) Assemblies
- 16 36-in. wood stakes
- 24 12-in. polycarbonate stakes
- 1 Repair Kit

The folded Mid Section Fabric should be packed in the bag labeled "Mid Fabric Module."

For the Type I MGPTS, the bag labeled "Mid Poles," should have the following contents stored in it:

- 2 Tent Pole (Y) Assemblies
- 4 Tent Pole (Side) Assemblies
- 8 36-in. wood stakes
- 12 12-in. polycarbonate stakes

Ensure that transport bags are in one location and ready for shipment or storage.

Storage of the MGPTS should be short, if not maintained. Items should be mission readied for deployment within 24 hours. While in storage, maintenance records should be kept. Before placing the MGPTS in long-term storage, all problems should be fixed. All Modification Work Orders (MWO's) should be incorporated.

**STORAGE SITE SELECTION**

Inside storage is preferred for items selected for long term storage. If inside storage is not available; trucks, vans, and other containers may be used.

**END OF WORK PACKAGE**



---

**OPERATOR'S AND UNIT MAINTENANCE  
MODULAR GENERAL PURPOSE TENT SYSTEM (MGPTS)  
NSN 8340-01-516-6860, NSN 8340-01-516-6861, NSN 8340-01-516-6863  
NSN 8340-01-516-6859, NSN 8340-01-516-6864, NSN 8340-01-516-6865  
TYPE II-OPERATION UNDER USUAL CONDITIONS**

---

This section applies to the Type II MGPTS only. If you are setting up a Type I MGPTS go back to work package 0004 00 titled TYPE I-Operation Under Usual Conditions.

### NOTE

These instructions are based on the medium MGPTS. For other tent sizes, the number of mid sections and poles will differ. Make modifications as required.

### SITTING REQUIREMENTS

Select an area to erect the tent. Ensure the area will be large enough for the tent and guy ropes that will be erected (see Table 1). The area should be clear of trees, rocks and debris. Choose a relatively flat area, the ground should not vary by more than 6 inches. A trench should be dug around the perimeter of the tent about 2-ft away from the edge. A drainage ditch should also be dug for water to exit the perimeter trench.

**Table 1. Area Setup Requirements.**

<b>Tent Model:</b>	<b>Length</b>	<b>Width</b>	<b>Height</b>
Small	34 ft	34 ft	12 ft
Medium	52 ft	34 ft	12 ft
Large	70 ft	34 ft	12 ft

### LAYOUT FABRIC SECTIONS

1. Identify each fabric section required. For the medium MGPTS you will need two end fabric sections and one mid fabric section.

## LAYOUT FABRIC SECTIONS – continued

**WARNING**

Fabric sections are heavy. Always lift with your legs not your back. Failure to observe this warning may result in back injury.

2. Transport each required fabric section into area where tent will be erected.
3. Unfold each mid fabric section **(1)** and end section **(2)** so that the inside (white side) is down and the green or tan side is up. Place these sections in center area where tent is to be setup.
4. The mid fabric section **(1)** has lace and grommets on both ends.
5. The end sections **(2)** have lace and grommets on one end.
6. Position end sections **(2)** on either side of the mid section **(1)** so that becket laces **(3)** align. Lay tent out flat. Fold side walls and end walls of mid **(1)** and end sections **(2)** under roof section so that only roof portions are exposed. This will allow easier access to the pole attachment points.

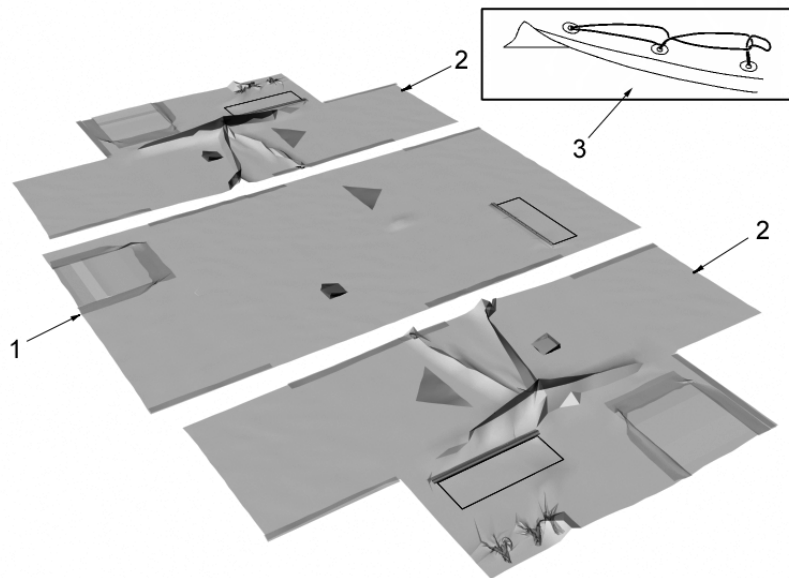

**CONNECT FABRIC SECTIONS**

Use the following procedures to connect becket lace between each end section and mid section:

**NOTE**

Split the four personnel into two person teams. Each team should perform steps 1-12 at the same time on opposite ends of the tent.

1. Find the two large snap hooks **(1)** at the center edge of end section and mid section roofs on underside of tent. Connect the snap hooks **(1)**.

**NOTE**

Type II tent system will have set of two snap hooks to be connected.

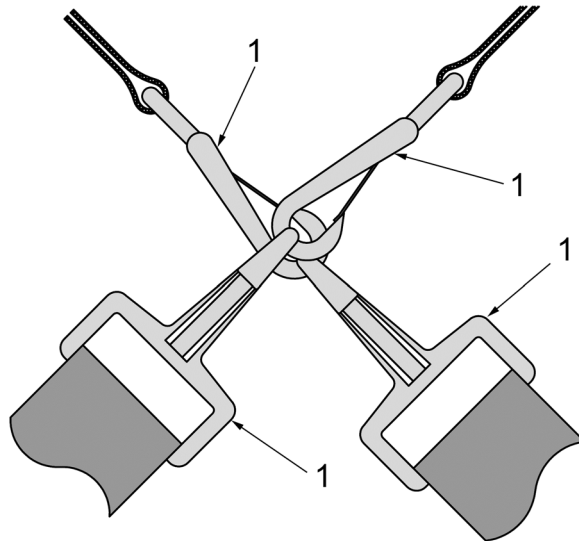

2. Find becket lace **(2)** at one end of roof. You may start at either end of roof.

**CONNECT FABRIC SECTIONS - continued**

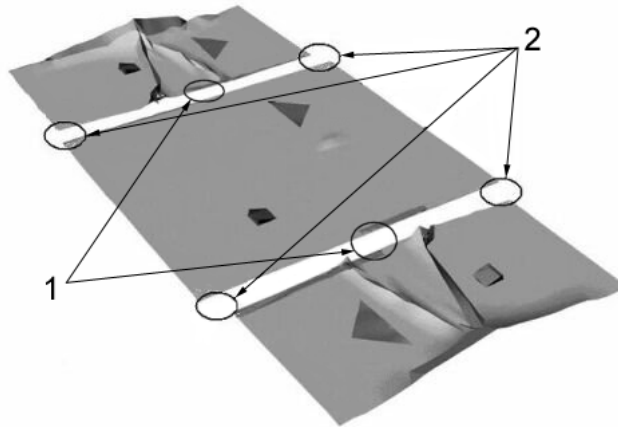

3. Lace the fabric sections together by using the following instructions. Insert the first rope loop (3) on one roof section through the first small grommet (4) of the adjoining roof section (5). Loops always enter the white side of the fabric and exit the green or tan side. All loops should be pulled tight. Insert the second loop (6) through the second grommet (7) and through the first loop (3). Insert the third loop (8) through the third grommet (9) and the second loop (6). Repeat this pattern until reaching the other side of the tent.

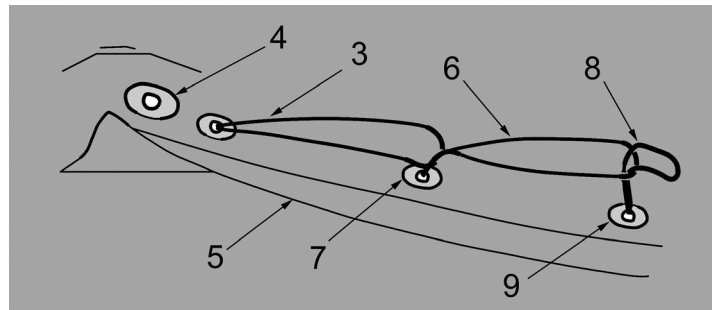

**NOTE**

Each grommet must have a loop inserted.

4. At the peaks of the tent you will need to pull the hanger pin (10) on the peak fitting (11) through the grommet on the lace line.

CONNECT FABRIC SECTIONS - continued

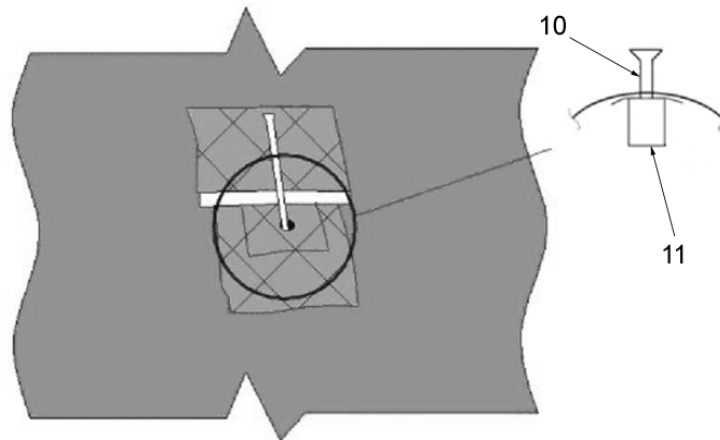

- At the end, tie off last becket lace by using the following instructions: Insert the next-to-last becket lace (12) through loop of last becket lace (13). Pull the next-to-last becket lace (12) back towards the ridge and tie off with half-hitch knot.

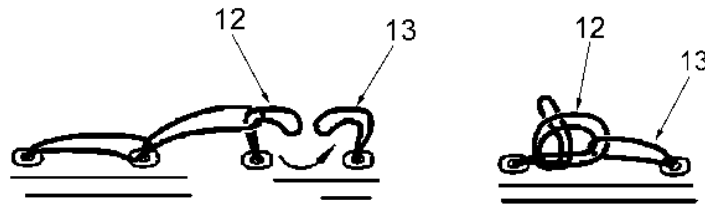

- Pull 1-1/2 inch web pole loop (14) through grommet (15) at eave.

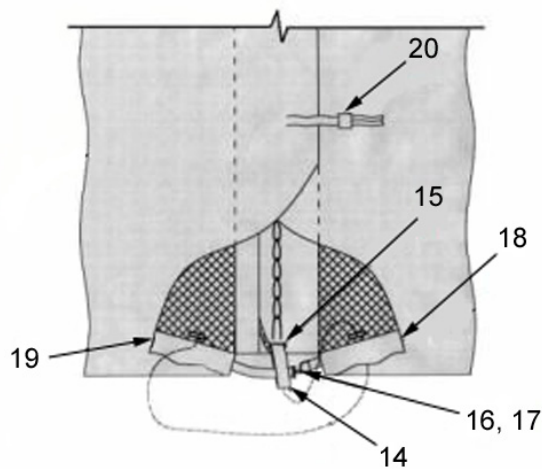

**CONNECT FABRIC SECTIONS - continued**

7. Connect D-ring (16) on  $\frac{3}{4}$ -in. strap at the eave to adjoining section's snap hook (17).

**NOTE**

Make sure d-ring strap is below 1-1/2-in. web pole loop.

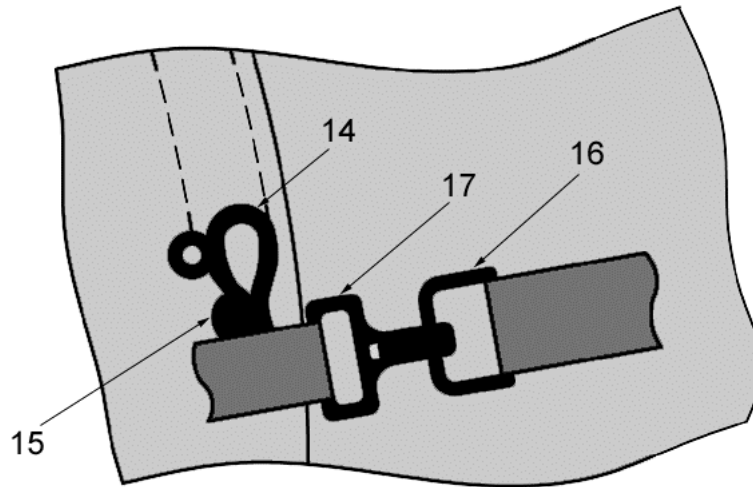

8. Flaps are identical. It does not matter which is on top or bottom.
9. Fold one full-length flap (18) over becket lace and pull the 1-1/2 inch web loop at each eave through the slit in the flap.
10. At the peak of the tent open both hanger pin opening covers. Push the hanger pin through the hanger pin opening in the flap at each hanger pin location. Connect the buckles along the lace line.
11. Fold the other full-length flap (19) over first flap (18) and pull the 1-1/2 inch web loop at each eave through the slit in the flap.
12. Push the hanger pin through the hanger pin opening in the outer flap at each hanger pin location. Pull both hanger pins to its full extension.
13. At center of tent, additional flap with hook and pile fasteners (21) must be attached to outer flap. Connect buckles after flap is installed. Roll additional unused center flap and connect buckles.

**CONNECT FABRIC SECTIONS - continued**

14. Connect buckles along entire outer flap.

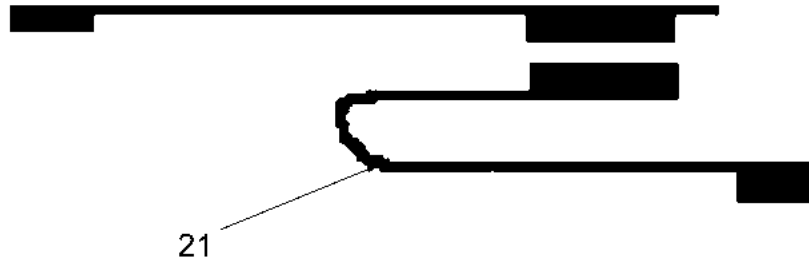

15. Repeat for all lace lines.
16. With one person at each corner of the tent, fabric should be stretched tight to remove slack.

**SETUP TYPE II TENT SYSTEM****WARNING**

Use care to ensure fingers, or other parts are not caught in frame rafter assembly hinge points.

**NOTE**

Split the four personnel into two person teams. Each team should perform steps 1-8 on opposite sides of the tent.

1. Locate three frame rafter assemblies **(1)**. Do not open the rafter arms while carrying the frame rafter assemblies. Lay the frame rafter assemblies on the ground.

SETUP TYPE II TENT SYSTEM - continued

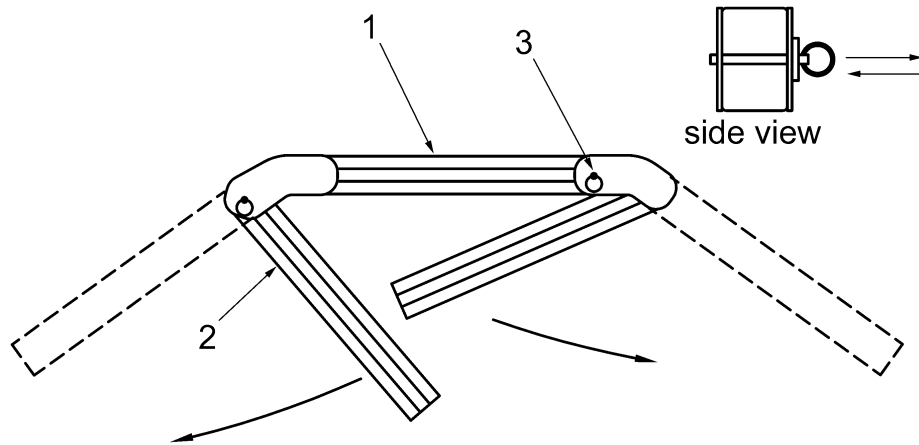

2. For each frame rafter assembly unfold the rafter arms (2). Lock the rafter arms (2) in place by pulling pin (3) out, aligning the holes in the rafter arm with pin (3), and pushing pin (3) back into the arm.
3. Locate the hangar pin (4) on the tent fabric (5).

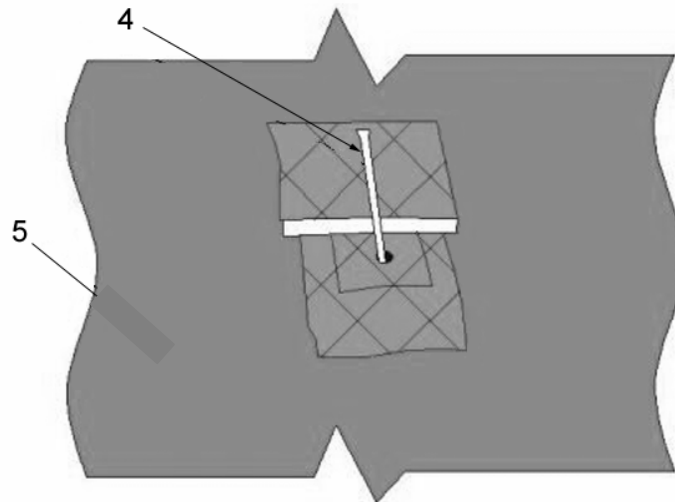

4. Lay the frame rafter assemblies (1) on the tent fabric (5) with openings on frame hanger assembly (6) facing up.



**SETUP TYPE II TENT SYSTEM - continued**

5. Slide-open the metal tab on the frame hangar assembly (6).
6. Insert hanger pins (4) into opening on frame hangar assembly (6).

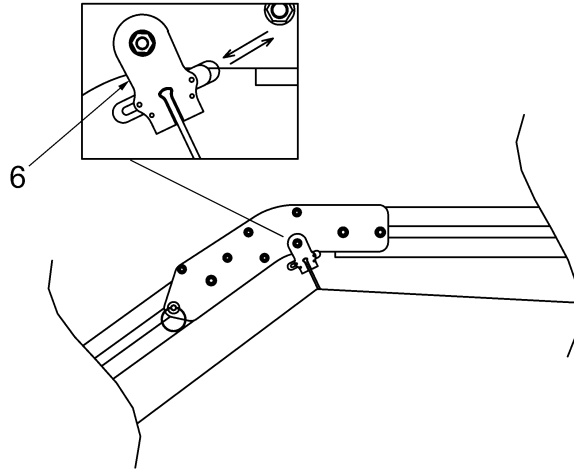

7. Close opening by sliding metal tab for each peak.
8. Repeat steps two through seven for all remaining arch assemblies.
9. Locate side poles (7). Four side poles are required for the Type II Tent System. Make sure each side pole (7) has two guy ropes (8) attached to cap assembly (9).
10. Place one side pole (7) at each corner of tent fabric (5). Place cap assembly spindle (10) through 1-1/2-in. web loop (11) at each corner eave.

SETUP TYPE II TENT SYSTEM - continued

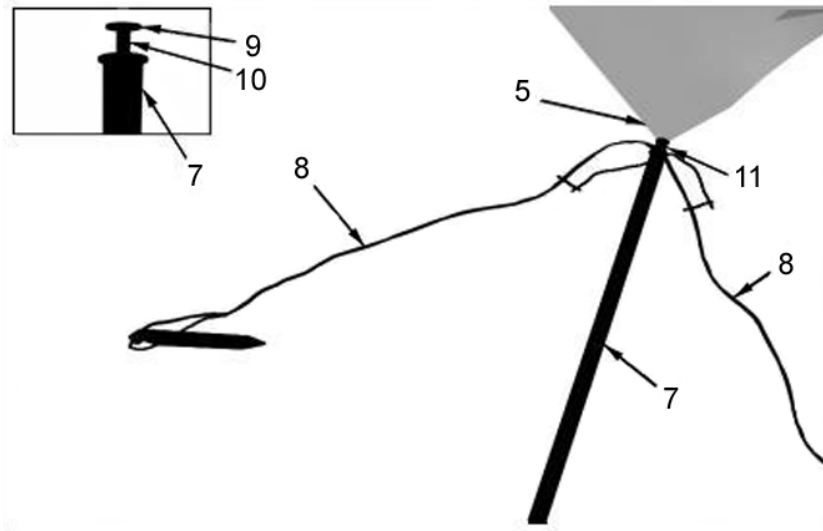

**NOTE**

At corners of tent, make sure web loops are pulled through slit in fabric shingle.

11. Find two end poles (12). Adjust them to maximum height by pulling pin (13) out at bottom of pole. Push pin (13) back in when holes are aligned. Place cap assembly spindle (9) through 1-1/2-in. web loop at middle of each tent end section's roof edge. Place flat side of end pole towards tent so that guy ropes slide freely through ring at top.

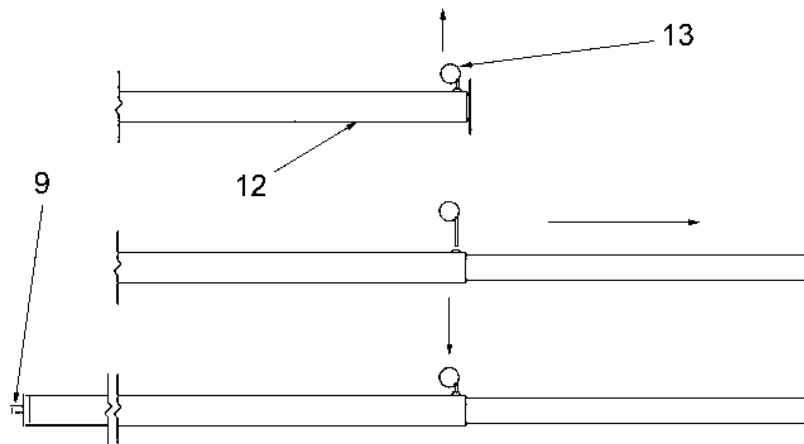

**SETUP TYPE II TENT SYSTEM - continued**

12. Poles at the corner should be aligned with fabric seam (14) in end section roof. Position stakes one foot from base of pole and one foot to each side of pole.

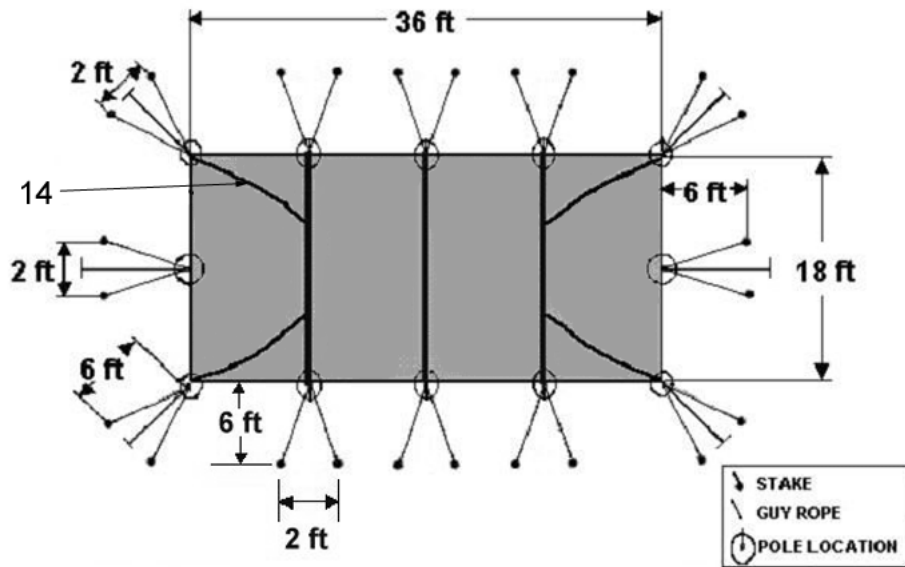

13. End poles (12) can be staked by placing stakes (15) one foot from upper leg edge and one foot to each side of end pole.

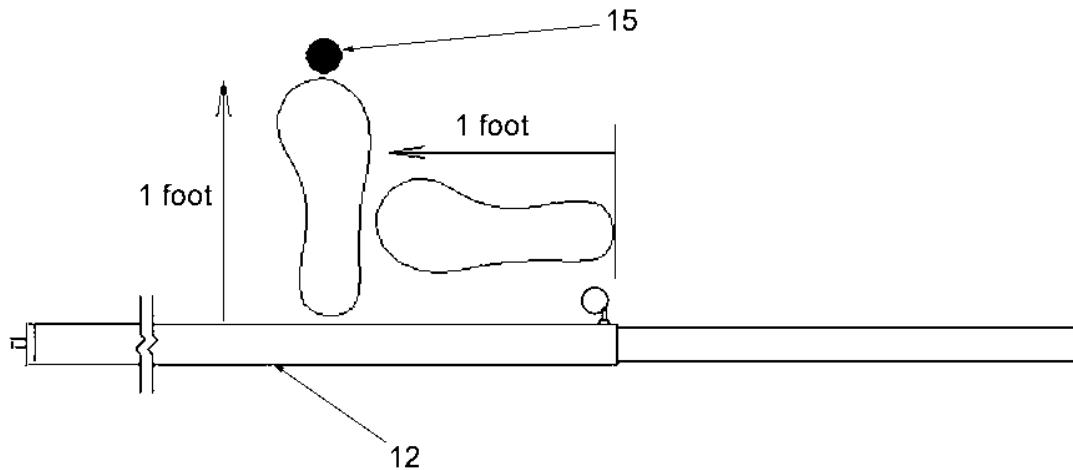

14. Follow staking diagram above. Drive in 36-inch wood stakes at all points indicated on diagram.

15. It is important to have a stake at each of the marked points.

**SETUP TYPE II TENT SYSTEM - continued**

16. Drive stakes six feet out from tent edge and angle stake slightly away from tent.
17. Wood stakes should be driven in until only six inches extend above the ground.

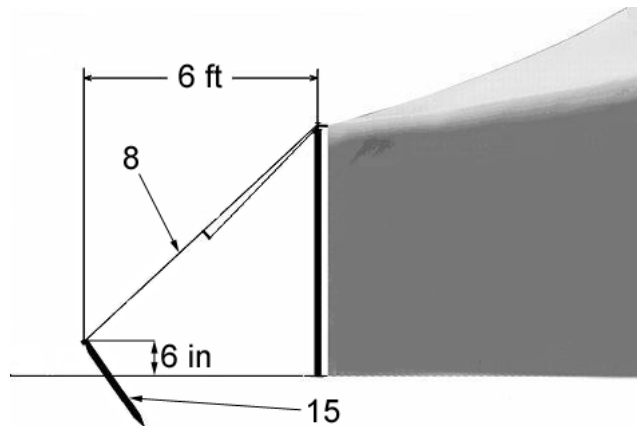

18. Place guy ropes (8) over wood stakes (15), making sure that ropes are not twisted. Loosen rope adjustment to leave plenty of slack. This will make it easier to stand poles up. Connect guy ropes at all pole locations.

**RAISING TYPE II TENT SYSTEM**

1. Two persons are required. Start at one corner. One person lifts corner roof fabric (1) while the second person grasps pole (2) and rotates bottom of pole under roof fabric (1) and stands pole up so that bottom of pole is angled in toward center of tent. Snug guy ropes (3) by sliding the tensioner (4) to keep poles from falling.

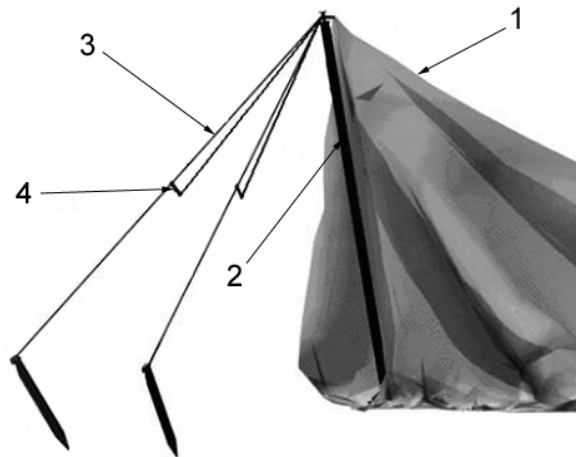

2. Repeat step one for other three corners.

**RAISING TYPE II TENT SYSTEM - continued****NOTE**

Guy ropes must be snug, to keep poles from falling.

3. Two persons are required. Stand end poles up on each end of the tent. One person lifts roof fabric **(1)**. Other person grasps pole, rotates bottom of pole under roof fabric **(1)** and stands pole up so that bottom of pole is angled slightly in towards center of tent. Place flat side of end pole towards tent so that guy ropes slide freely through ring at top. Snug guy ropes **(3)** to keep poles from falling.
4. Repeat for other end pole.
5. Locate the frame leg sections **(5)**. With the frame leg section on the ground, adjust the leg to the maximum height by pulling out the locking pin **(6)**, extending the leg section to the maximum position and then pushing the locking pin in through the aligned holes.

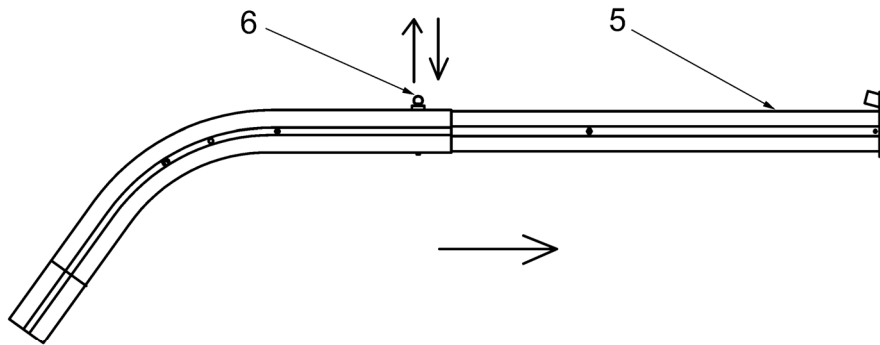

6. Slide the **frame leg section (5)** on to the **arch rafter assembly (7)** until it hits the stop bolt.
7. Repeat Step five and six for all frame leg sections.

RAISING TYPE II TENT SYSTEM - continued

**NOTE**

Remain in two-person teams for next step.

**NOTE**

When installing leg sections, ensure they are facing same direction.

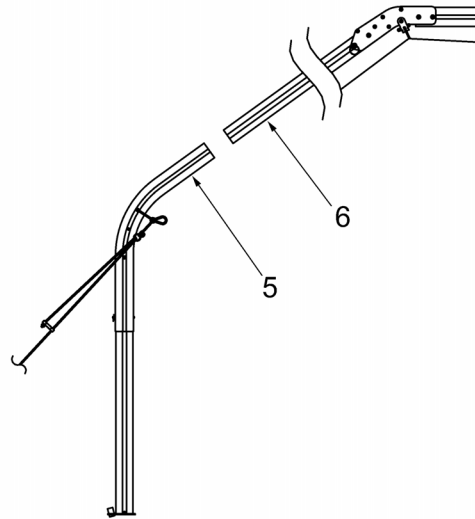

8. Beginning at the arch assembly (8) on one end, position two personnel on each side. Together, lift and walk the arch assembly into position.

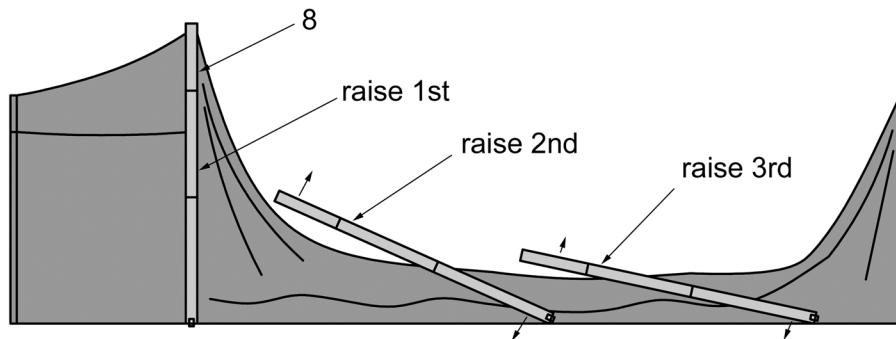

**RAISING TYPE II TENT SYSTEM - continued****NOTE**

If necessary, a fifth person inside tent, pushing up at the peak fitting will help to raise the tent.

9. At the arch assembly **(8)** in the middle, position two personnel on each side. Together, lift and walk the arch assembly into position.
10. At the arch assembly **(8)** at the end, position two personnel on each side. Together, lift and walk the arch assembly into position.
11. Locate the rope and snap assemblies **(9)** at the curved section of each arch assembly **(8)**. Locate the web pick up loops at the lace line. With one person on outside, locate one person on inside pushing fabric out and connect the snap to the web pick up loop. Repeat for all frame assembly snaps.

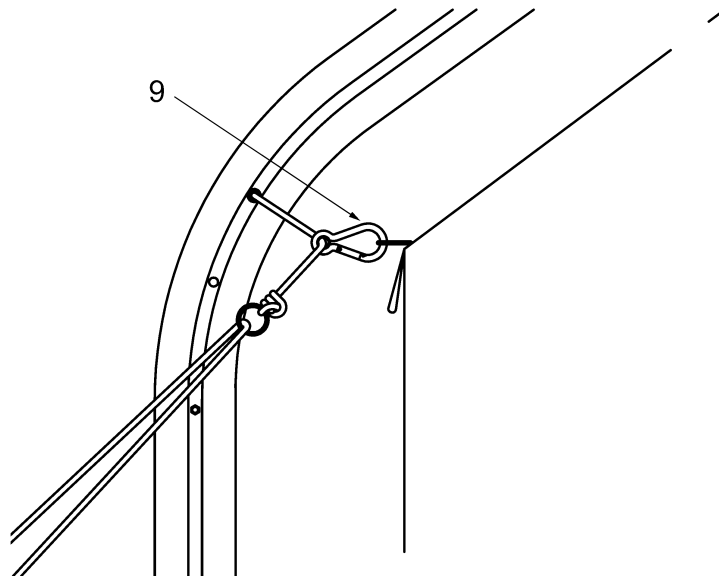

12. Locate the guy ropes on each of the arch assemblies. Cross guy ropes between arches and stakes on each arch and place the guy ropes over the wood stakes, making sure that ropes are not twisted.

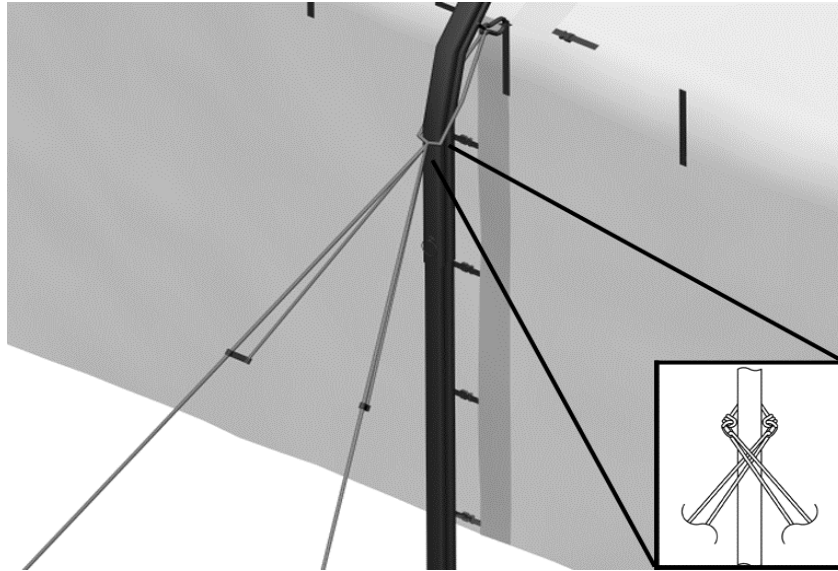
**RAISING TYPE II TENT SYSTEM - continued****TENSIONING TYPE II TENT SYSTEM**

1. Tensioning tent. Corners should be tensioned first. Tension one corner at a time.
  - a. Start at a corner. The first person should stand between the stakes **(1)** and pole **(2)**.
  - b. Grasp pole **(2)** at top, below cap assembly with both hands. This person rocks back towards stake **(1)** keeping base of pole in place.
  - c. Second person tightens guy ropes, by sliding tensioner **(3)** down guy rope **(4)**. Both people grasp side pole and straighten side pole **(2)** to vertical position.



## TENSIONING TYPE II TENT SYSTEM - continued

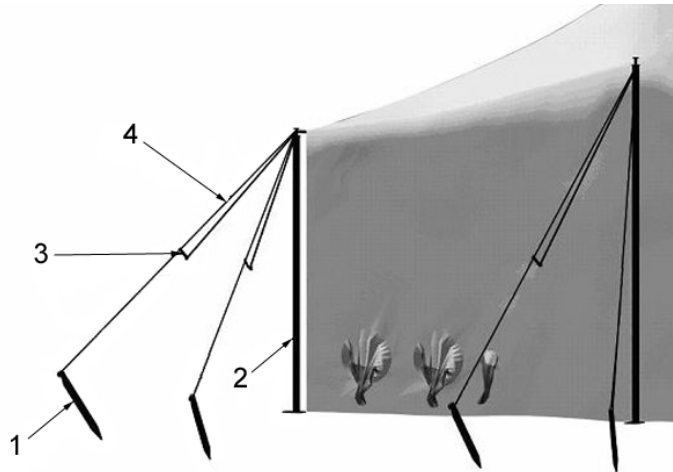

- d. Repeat procedure on other three corners.
- e. For each end pole. The first person should stand between the stakes **(1)** and end pole.
- f. Grasp the pole at top, below cap assembly with both hands. This person rocks back towards stake **(1)** keeping base of pole in place.
- g. Second person tightens guy ropes, by sliding tensioner **(3)** down guy rope **(4)**. Both people grasp end pole and straighten to vertical position.

**NOTE**

Sidewall can be configured in three different ways: all walls down, cloth walls rolled up with screen walls down, both cloth walls and screen walls rolled up.

2. If lights, liner, or plenum are authorized, lower the frame arches in the following manner:
  - a. Roll up one 9-ft long sidewall section of the tent. Use tie straps at eave to secure the rolled up section.

**TENSIONING TYPE II TENT SYSTEM - continued**

- b. Starting at one end, disconnect the guy ropes from the frame assembly from the stakes only. Leave the snap connected to the web loop. Repeat for all arch assemblies.
  - c. Remove stakes from stake tubes at the base of frame arches (if installed).
  - d. Starting at one end, with two persons at each frame leg, lower the frame assembly.
  - e. Loosen guy ropes for end poles.
  - f. Remove stakes from stake tubes at the base of the end poles (if installed).
  - g. Lower end poles so that d-rings on inside peak(s) are within reach.
  - h. If liner is authorized, install the liner before lights and plenum (see WP 0007 00).
  - i. Install lights if authorized (see page 0005 00-17) before installing plenum (if authorized).
  - j. Install plenum if authorized (see work package 0008 00).
3. If lights, liner or plenum have been installed, raise the frame arches in the following manner:

**NOTE**

Two persons are required.

- a. Raise the end poles. Stand end poles up on each end of the tent. One person lifts roof fabric. Other person grasps pole, rotates bottom of pole under roof fabric and stands pole up so that bottom of pole is angled slightly in towards center of tent.
- b. Place flat side of end pole towards tent so that guy ropes slide freely through ring at top. Snug guy ropes to keep poles from falling.
- c. Starting at one end of the tent, with two people at each arch leg, re-raise the arch.
- d. At the middle frame arch, with two people at each arch leg, re-raise the arch.

**TENSIONING TYPE II TENT SYSTEM - continued**

- e. At the last frame arch, with two people at each arch leg, re-raise the arch.
- f. Locate the guy ropes on each of the arch Assemblies. Cross guy ropes between frame arch and stakes on each arch and place the guy ropes over the wood stakes, making sure that ropes are not twisted.
- g. Tighten the guy ropes on all of the arch assemblies by sliding the dog bone toward the stakes.

**NOTE**

Make sure all arch assemblies are in a vertical position as well as end poles and poles at the corner.

4. Secure vertical fabric sections. For both attachment points of wind straps on sidewalls, pull straps through slit on opposing wall section.
  - a. Pull both sets of wind straps through the corresponding slit on outer flap.
  - b. Starting at the top of the vertical fabric sections attach fabric sections together with fasteners.
5. Starting at top of vertical fabric sections, connect the four buckles on outer flap.
6. Wrap both wind straps around pole and tie straps with an appropriate knot so that the sidewalls hang vertically.
7. Attach hook and pile fasteners on rain flaps to sidewall flap for blackout integrity.
8. Repeat steps four through seven for all vertical fabric section mating areas.
9. Staking sidewalls and poles:
  - a. Locate the 12-inch polycarbonate stakes.
  - b. Locate the rope loops **(1)** at the base of the side walls.

TENSIONING TYPE II TENT SYSTEM - continued

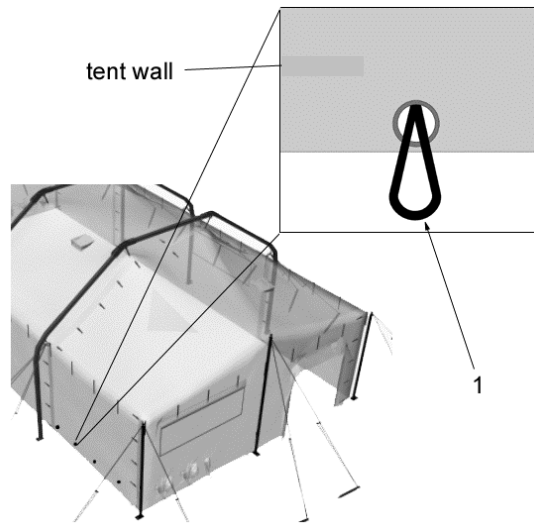

- c. Insert finger into rope loop, twist rope loop to form a figure 8. Place the two newly created loops around finger. Insert stake into both loops and drive stake into ground.

**NOTE**

Do not drive 12-in. stakes all the way into the ground; leave them about two inches out. This will make it easier to remove the stakes.

- d. Drive a stake through the stake tube (2) at the base of all frame arches and poles.

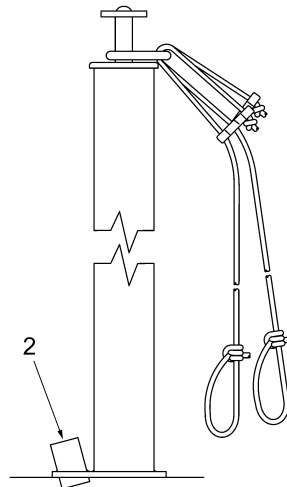

## INSTALL LIGHT ASSEMBLIES

## NOTE

If the arch assemblies and end poles are raised, they must be lowered before the lights can be installed and re-raised after, refer to page 0005 00-26 for lowering and 0005 00-11 for raising instructions.

1. Inside light set case (1), locate light support strap assembly (2).

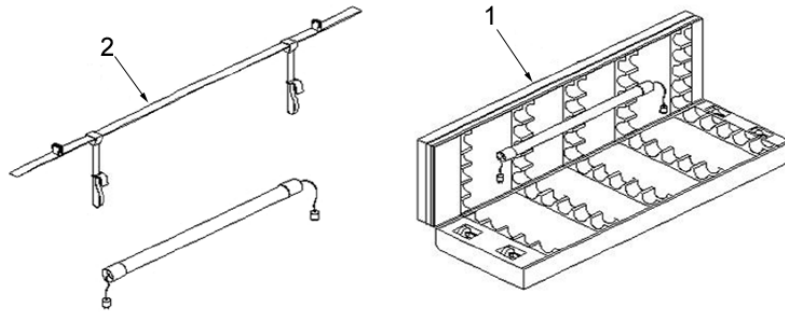

2. Inside tent, locate light hanger (3) at peak of end section fabric.

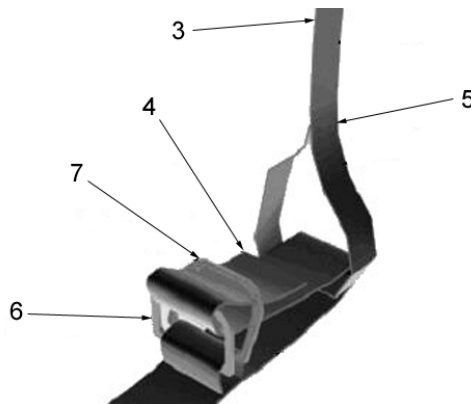

3. Place one end (4) of light support strap assembly (2) through loop (5) on end of lighting hanger (3). The d-rings should now be facing the ground.
4. Light support strap assembly (2) is then folded over itself so that D-rings (6) and (7) face the tent roof.
5. Pull the end (4) of light support strap assembly (2) through both D-rings (6) and (7) on assembly. Loop end (4) of assembly around the second D-ring (6) and through the first D-ring (7) to secure.

**INSTALL LIGHT ASSEMBLIES - continued**

6. Locate light hanger attached on inside of fabric near the peak fitting.
7. Secure other end of light support strap assembly **(2)** to light hanger and secure in similar manner.
8. Repeat procedure one through seven for light strap assembly between the mid and end section.
9. Install lights.



---

**WARNING**

---

Two persons are required to lift light set case to avoid injury to personnel.

**NOTE**

To prevent damage, leave luminaries in case until ready to install. Make sure male plug end is toward external power source.

- a. Wrap strap loops around each end of light on inside of rubber end caps.
- b. Pull strap up through d-ring and press down to engage hook and pile fasteners.
- c. Mate plug properly to next light, ensuring reflecting surface faces up and lamp faces down.
- d. Repeat step a through c for additional lights.

---

**CAUTION**

---

Do not connect more than 12 lights together. Damage to electrical circuit may result.

- e. Connect lights.

**INSTALL VESTIBULE**

When authorized, vestibule may be used as a passageway or blackout entryway. It may be connected to an end or mid section doorway. Erect the vestibule as follows for all configurations.

1. Remove the stakes that block the path of the vestibule and re-stake them in a position out of the vestibule's way.
2. Tension the relocated stake's guy ropes again.
3. Locate and unroll vestibule adapter at tent door.

**INSTALL VESTIBULE - continued**

4. Locate, layout, and assemble vestibule arch assembly (1) components. The vestibule arch assembly (1) comprises of a vestibule header (2) and two legs (3).

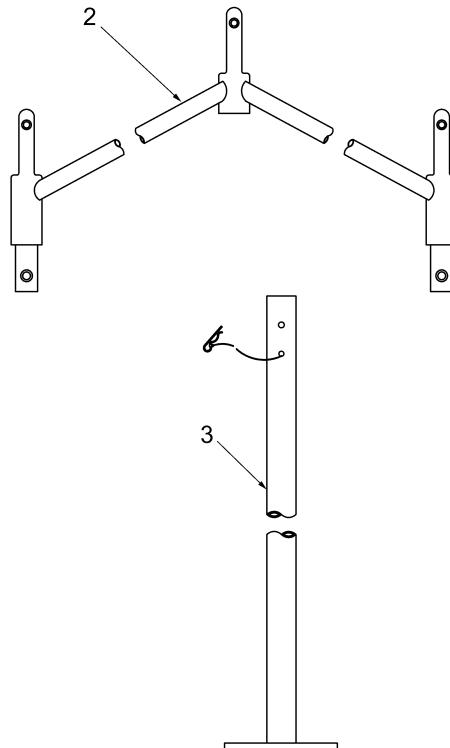
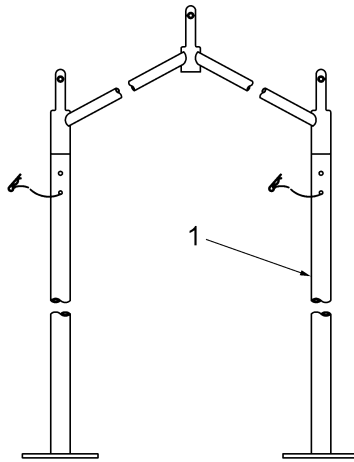

**INSTALL VESTIBULE - continued****CAUTION**

Position hitch clip pin (the curved part) towards inside of vestibule arch assembly. Vestibule fabric may tear if (the curved part) hitch clip end is pushing against the fabric. Failure to comply may result in damage to the equipment.

5. Open tent door and place all vestibule arch assemblies **(1)** inside.
6. Starting at the vestibule peak, becket lace the vestibule fabric to the adapter through grommets **(4)** lacing towards the eave, tie off with half hitch knot. Becket lace the vestibule fabric to the adapter through grommets lacing towards the ground, tie off with half hitch knot. Repeat this procedure for the other side of the vestibule.

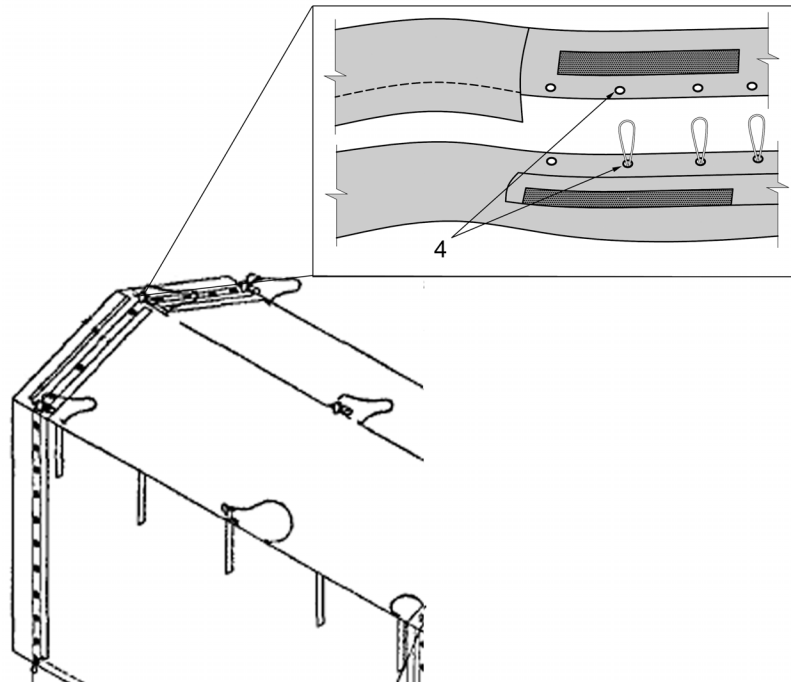

7. Align vestibule spindle grommet **(5)** with vestibule adapter spindle grommet **(5)**.



## INSTALL VESTIBULE - continued

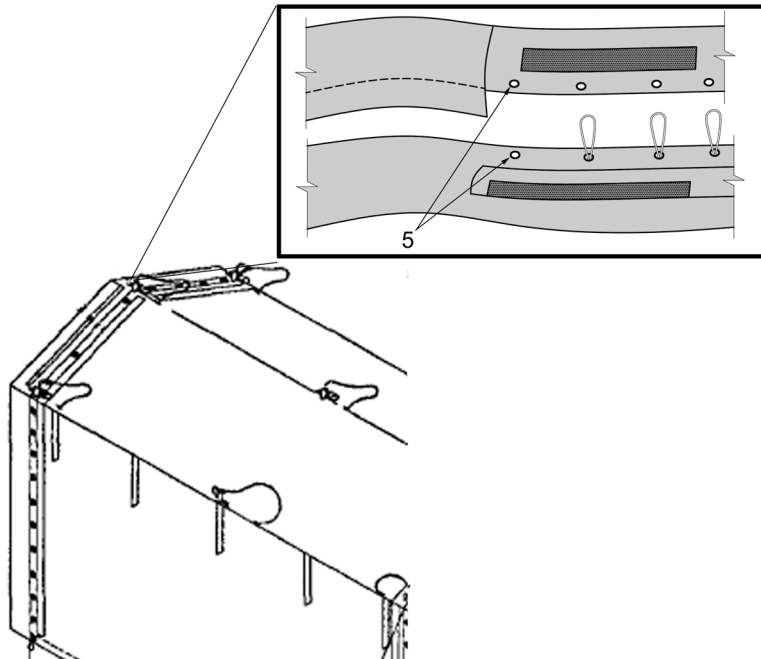

8. Insert vestibule frame spindles in vestibule spindle grommet and vestibule adapter grommet. Secure ridge grommets with hitch clip pins.
9. Raise vestibule arch assembly **(1)** into a vertical position.
10. Repeat steps eight and nine for the remaining vestibule arch assemblies.
11. Extend arches and fabric.
12. Install two guy ropes under hitch clip pins on eave spindles of last vestibule arch.
13. Place 24-in. wooden stakes about 6 feet out, facing towards vestibule door.
14. Tie guy ropes to stakes and tighten.
15. Secure vestibule fabric to vestibule arch with tie tapes.

---

## **OPERATING PROCEDURES**

### **Operate Doors**

Use following procedures to operate door on MGPTS:

Door is opened and closed using hook and pile fasteners. The inner door can be rolled up (towards the inside to prevent rain from being trapped within the folds) and secured with straps at the top.

Outside the tent there is a sliding door. The sliding door can be secured in the open position with attached straps, and secured in the closed position with buckles.

### **Operate Windows**

Windows can be opened for ventilation or closed due to inclement weather. Windows have three panels.

The fabric cover and clear windows are closed by hook and pile fasteners.

The fabric cover and clear window can each be held open with tie tapes.

Each layer must be rolled up towards the inside to prevent rain from being trapped within the folds. To fully close the fabric cover, the clear window must first be unrolled and secured.

---

**OPERATING PROCEDURES – continued****Operate Roof Vents**

---

**WARNING**

---

Do not use any type of non-vented heaters. The use of non-vented heaters will cause the accumulation of carbon monoxide gas. Carbon monoxide gas is not visible and it has no smell. If symptoms of headache, dizziness, fatigue, nausea, or irregular breathing occur, move affected personnel to fresh air. Failure to comply with this warning may result in personal injury or death.

All fuel burning heaters consume oxygen. Adequate ventilation must be maintained at all times. Keep roof vents clear of snow, ice, or debris. Open doors, windows, flaps, hook and pile fastener wall closures as needed to introduce sufficient fresh air to replace oxygen consumed by heaters. If symptoms of headache, dizziness, fatigue, nausea, or irregular breathing occur, move affected personnel to fresh air. Failure to comply with this warning may result in personal injury or death.

**NOTE**

Roof vent is made from foam and is always open; no operation is required.

**Operate Fabric Walls**

Outside walls can be rolled up (towards the inside to prevent rain from being trapped within the folds) and tied off for ventilation if needed.

**Operate Stovepipe Openings**

The stovepipe vent is opened and closed by pulling the cord **(1)** attached to the vent cover **(2)**. To open, pull the cord **(1)** to the opposite side of the tent. To close, pull cord to the near side. The vent cover will secure itself when it is closed.

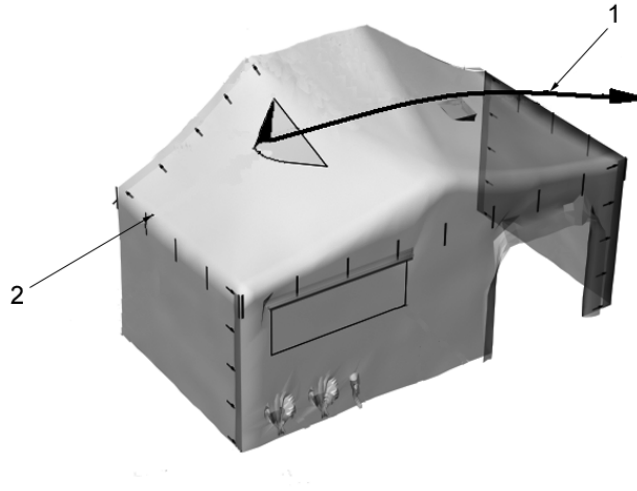
**OPERATING PROCEDURES - continued****REMOVE VESTIBULE**

Use following procedures to remove the vestibule:

1. Remove the 12-inch pins in base plates of end vestibule arch.
2. Loosen guy lines to stakes.
3. Remove 24-inch wooden stakes.
4. On last vestibule arch remove two guy ropes on eave spindles.
5. On tent door, untie Becket Lace from ridge to eave, unseal weather flap, remove the remaining hitch clip pins and complete becket unlacing.
6. Remove vestibule arch spindles from grommets.
7. Remove vestibule arch and fabric from adapter.
8. Repeat procedures one through seven for remaining vestibule(s).

**STRIKING TYPE II TENT SYSTEM****WARNING**

Disconnect power source to avoid injury to personnel during removal of light assemblies. Unmate light plugs to prevent damage to light assemblies during tent striking. Failure to comply may result in serious or death to personnel.

1. Make sure fabric is dry before disassembly.
2. Untie all wind ties from poles.
3. Unfasten buckles on sidewalls. Open outer and inner flap, pulling straps through slits.
4. Detach hook and pile fasteners at sidewall connections.
5. Repeat this procedure until all of side and corner wall connections are detached.
6. Unroll side walls if they are secured with tie straps.
7. Disconnect guy ropes on frame arches from stakes.
8. Disconnect snaps **(1)** on frame arches from web pickup loops for all frame arches.

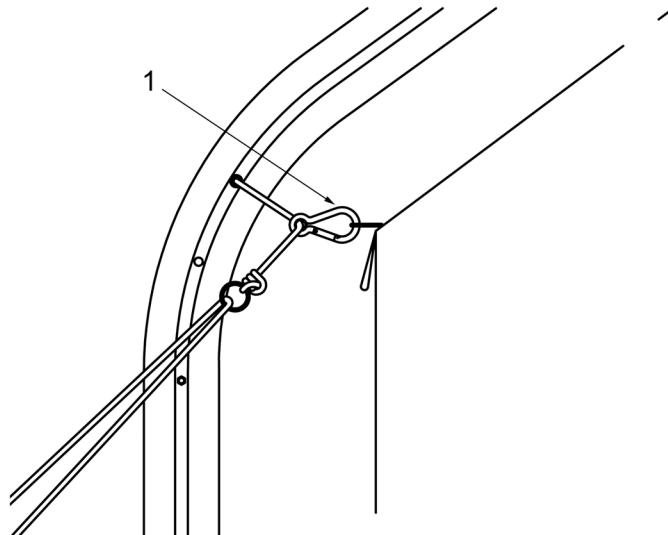

**STRIKING TYPE II TENT SYSTEM - continued**

9. Lower frame arches.

**NOTE**

Do not straddle arch assembly when lowering to the ground.

- a. Using two persons on each side, starting at one end, together lift and walk the arch down from position slowly.
  - b. Using two persons, starting at the middle frame arch, together lift and walk the arch down from position.
  - c. Using two persons, starting at the last frame arch, together SLOWLY lift and walk the arch down from position.
10. Lower both end poles to the ground. Adjust them to minimum height and move to location for placement in bags. Release tension from guy ropes and lower both tent poles to the ground.

**NOTE**

If the MGPTS is equipped with a plenum, remove the plenum now and before the lights. Refer to WP 0008 00 for instructions.

**NOTE**

If the MGPTS is equipped with a lights, remove the lights now. Refer to "Remove Light Assemblies" in this work package for instructions.

**NOTE**

If the MGPTS is equipped with a Liner, remove the Liner now. Refer to WP 0007 00 for instructions.

11. Drop corner poles.

- a. Starting at one corner, loosen guy rope. Lower corner pole.
- b. Repeat step a for all corners.
- c. Move poles to location for placement in pole bags.

12. Remove arch assemblies.

- a. Starting at end of the tent, remove leg assemblies from frame arch.
- b. Lay leg assemblies on ground and retract leg assemblies.
- c. Move leg assemblies to location for placement in bags.

**STRIKING TYPE II TENT SYSTEM - continued**

- d. Disconnect arch from hangar pin on fabric by opening gate and removing pin for both gates.



---

**WARNING**

---

While folding up arch assembly arms caution must be used to avoid pinching fingers. Body parts may get pinched or caught. Failure to comply may result in serious injury to personnel.

- e. Position arch on ground off the tent and then fold arms up.
  - f. Move arch to location for placement in frame bag.
  - g. Repeat steps a through f for all arch Assemblies.
13. Separate fabric sections.
- a. Starting at a lace line on one end of the tent, disconnect buckles on rolled-up center flap not used.
  - b. Disconnect buckles on outer flap along entire length of lace line.
  - c. Disconnect hook and pile fasteners on center flap while pulling hanger pin out of hanger pin opening on outer flap.
  - d. Re-secure hanger pin opening flaps.
  - e. Pull outer flap back.
  - f. Disconnect buckles on inner flap, while pulling inner flap back. Pull hanger pins through hanger pin opening and pull inner flap back.
  - g. Re-secure hanger pin flaps on inner flap.
  - h. Unhook d-ring and undo snap hook at each eave joint section. Unlace becket lace.
  - i. Push hanger pins back through flaps, through grommet on lace line and into peak fitting.
  - j. Remove becket lace from grommets.
  - k. Unhook snap hooks at the peak of tent where fabric sections connect.
  - l. Fabric sections should now be able to be separated.
  - m. Repeat steps a through m for all becket lace lines.

## REMOVE LIGHT ASSEMBLIES

Use the following procedures to remove the light support strap assemblies:



### **WARNING**

Disconnect power source during removal of light assemblies. High Voltages are present. Failure to comply may result in serious or death to personnel.

1. Locate light case.
2. Turn off light and disconnect from power source.
3. Pull light support strap down through d-ring and disengage hook and pile fasteners.
4. Unwrap light support strap around each end of light.
5. Place light in light case.
6. Repeat steps one through five for removal of additional lights.
7. Remove light support strap assembly.
8. Place light support strap assembly in light case.

## FOLD FABRIC SECTION

Ensure that all elements of the MGPTS are inspected as specified in the Preventive Maintenance Checks and Services (PMCS), WP 0011 00.

The following section will demonstrate tent packing procedures for the MGPTS:

1. Both end sections are to be folded as follows:
  - a. Start with the end fabric section spread out flat, with the green or tan side facing upward.
  - b. Fold each end section wall over the end section roof as shown.
  - c. Fold edges of roof inward on themselves, so that both meet at the center of the end section roof.
  - d. Fold fabric in half, so that the entire width of the folded section is less than 5 feet.
  - e. Roll fabric as illustrated.
  - f. Place tent contents in properly labeled bags.



FOLD FABRIC SECTION - continued

END SECTION

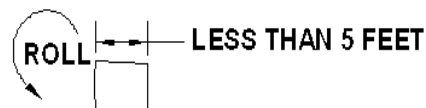
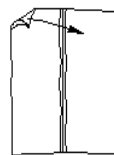
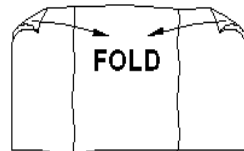
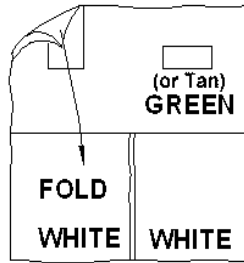
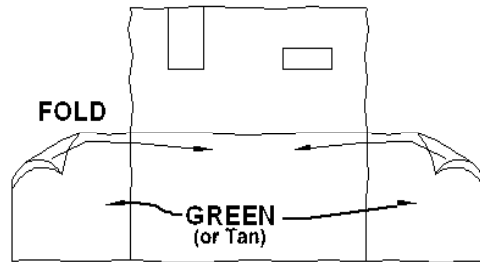

2. The mid sections (if used) are to be folded as follows.
  - a. Start with the mid section spread out with the green or tan side up, as shown below.
  - b. Fold mid section walls over mid section roof so that the two outer edges of the fabric meet at the middle of the roof.
  - c. Fold the mid section fabric in on itself as illustrated, so that the edges meet at the middle of the roof.

**FOLD FABRIC SECTION - continued**

- d. Fold the edges of the mid section one final time, so that the width of the folded section is less than five feet.
- e. Roll fabric as illustrated.

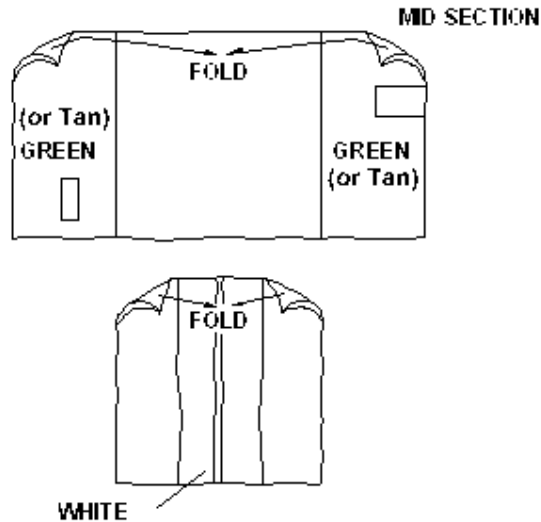
**NOTE**

Check all poles to ensure they are folded and locked in their original shipped condition. End poles should be retracted and locked at their original 7-ft height. Side and end poles should have guy ropes and all original equipment attached as specified in the RPSTL WP 0027 00 and WP 0028 00. Arch assemblies should have the frame arms folded and locked and the arch leg section retracted and locked in the original height.

3. Place tent contents in properly labeled bags.

The folded end section fabric should be packed in the bag labeled "End Fabric Module".

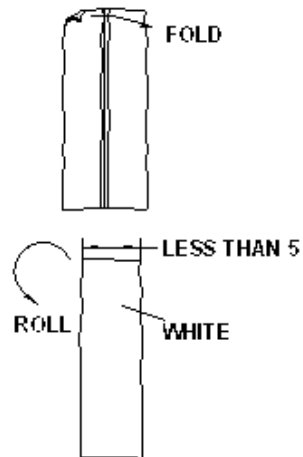
**FOLD FABRIC SECTION - continued**

The bag labeled "End Frame," should have the following contents stored in it:

- 1 Arch, Tent Frame
- 2 Tent Pole (End) Assemblies
- 4 Tent Pole (Side) Assemblies
- 16 36-inch wood stakes
- 24 12-inch polycarbonate stakes
- 1 Repair Kit

The folded mid section fabric should be packed in the bag labeled "Mid Fabric Module".

The bag labeled "Mid Frame," should have the following contents stored in it:

- 2 Arch, Tent Frames
- 8 36-inch wood stakes
- 12 12-inch polycarbonate stakes

Ensure that transport bags are in one location and ready for shipment or storage. Storage of the MGPTS should be short, if not maintained. Items should be mission readied for deployment within 24 hours.

While in storage, maintenance records should be kept. Before placing the MGPTS in long-term storage, all problems should be fixed. All Modification Work Orders (MWO's) should be incorporated.

**STORAGE SITE SELECTION**

Inside storage is preferred for items selected for long-term storage. If inside storage is not available, trucks, vans, and other containers may be used.

**END OF WORK PACKAGE**



**OPERATOR'S AND UNIT MAINTENANCE  
MODULAR GENERAL PURPOSE TENT SYSTEM (MGPTS)  
NSN 8340-01-477-1397, NSN 8340-01-477-1449  
FLOOR-OPERATION UNDER USUAL CONDITIONS**

**INSTALLING FLOOR IN TYPE I TENT SYSTEM**

This section applies to the Type I MGPTS only. If you are installing the floor in a Type II MGPTS go to the section labeled INSTALLING FLOOR IN TYPE II TENT SYSTEM.

**Table 1. Quantity of floor sections for the Type I MGPTS.**

	Quantity		
	Small	Medium	Large
End Section	2	2	2
Mid Section	0	1	2



**WARNING**

Floor sections are heavy. Always lift with your legs not your back. Failure to observe this warning may result in back injury.

1. Identify each floor section required. For the medium MGPTS you will need two end floor sections (1) and one mid floor section (2).

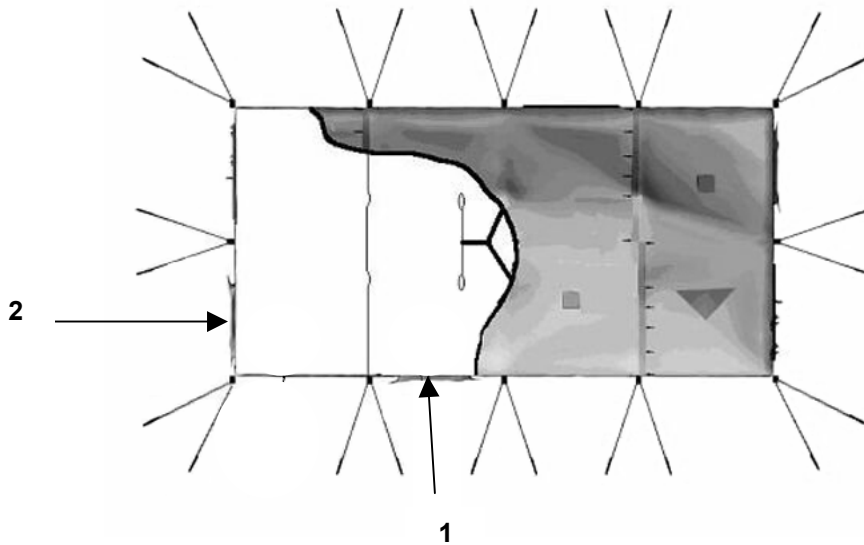

**INSTALLING FLOOR IN TYPE I TENT SYSTEM - continued**

2. Transport an end floor section into the tent. Unfold the end floor section with the dull textured surface up. Position the corners of the end floor section to match the corners of the tent.
3. Smooth out end floor section.
4. Align floor flap around Y pole.
5. Transport another end floor section into the tent. Unfold the end floor section at the other end of the tent, with the dull textured surface up. Position the corners of the end floor section to match the corners of the tent.
6. Smooth out end floor section.
7. Align floor flap around Y pole.
8. Transport a mid floor section into the tent.
9. Lay the mid floor section in the center of the tent and unfold. Unfold the mid floor section with the dull textured surface up to one side of the middle Y pole.
10. Open the middle Y pole split hook and pile fasteners at the center of the mid floor section.
11. Pull the mid floor section around the Y pole. Wrap the floor flap around the middle Y pole. Reconnect the hook and pile fasteners only along the split around the Y pole on the inside and outside row of hook and pile fasteners.
12. Starting at one end of the tent, attach the hook and pile fasteners where the mid and end floor sections meet. Wrap the mid floor section floor flap around the Y pole.
13. Repeat this procedure for the other mid and end floor section hook and pile fastener.
14. At the perimeter of the complete floor assembly, attach the snaps to the corresponding d-rings on the fabric of the tent.

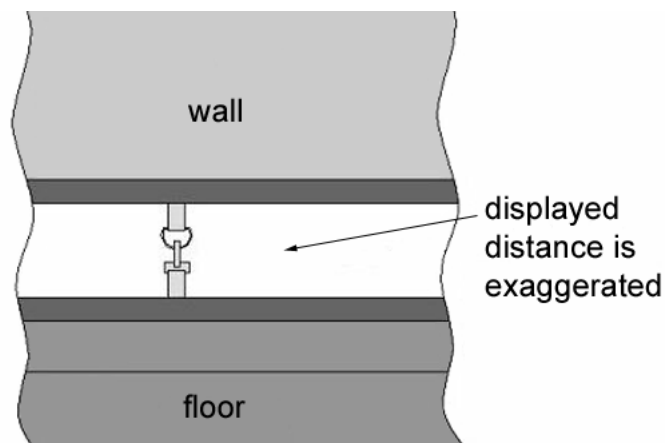

**INSTALLING FLOOR IN TYPE I TENT SYSTEM - continued**

**NOTE**

Not all snaps on the mid floor section will be used.

15. Smooth the completed floor.

**NOTE**

If liner is authorized, attach the hook and pile fasteners on the bottom of the liner to the hook and pile fasteners on the perimeter of the floor.

**INSTALLING FLOOR IN TYPE II TENT SYSTEM**

This section applies to the Type I MGPTS only. If you are installing the floor in a Type I MGPTS go back to the section labeled INSTALLING FLOOR IN TYPE I TENT SYSTEM.

**Table 2. Quantity of floor sections for the Type II MGPTS.**

	Quantity		
	Small	Medium	Large
End Section	2	2	2
Mid Section	0	1	2

1. Identify each floor section required. For the medium MGPTS you will need two end floor sections (1) and one mid floor section (2).

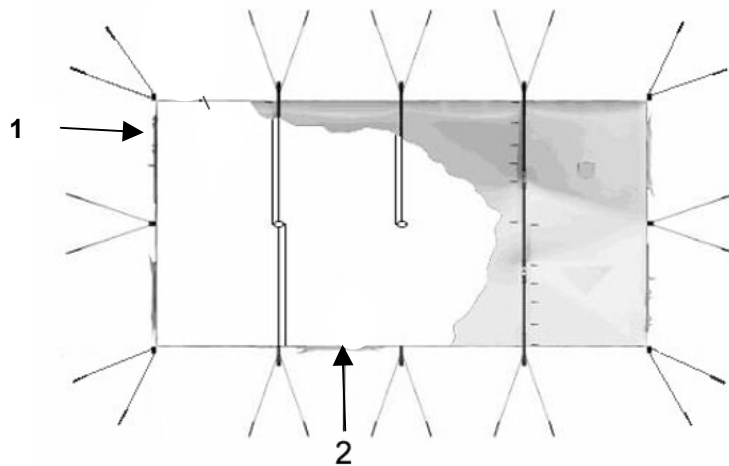

**INSTALLING FLOOR IN TYPE II TENT SYSTEM - continued****WARNING**

Floor sections are heavy. Always lift with your legs not your back. Failure to observe this warning may result in back injury.

2. Transport an end floor section into the tent. Unfold the end floor section with the dull textured surface up. Position the corners of the end floor section to match the corners of the tent.
3. The Y pole flap is not used for the Type II System and should be tucked under the floor toward the ground.
4. Transport the other end floor section into the tent. Unfold the end floor section with the dull textured surface up. Position the corners of the end floor section to match the corners of the tent.
5. The Y pole flap is not used for the Type II System and should be tucked under the floor toward the ground.
6. Transport a mid floor section into the tent. Lay the mid floor section in the center of the tent.
7. Unfold the mid floor section. Unfold the mid floor section with the dull textured surface up. The tent pole flap is not used for the Type II system and should be tucked under the floor toward the ground.
8. Connect the hook and pile fasteners between the mid floor section and the end floor sections.
9. At the perimeter, attach the snaps to the D-rings on the fabric of the tent.



**INSTALLING FLOOR IN TYPE II TENT SYSTEM - continued****NOTE**

Not all snaps on the mid floor section will be used.

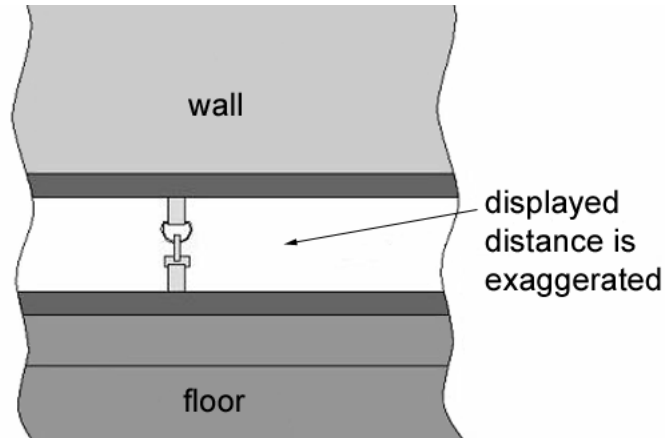

10. Smooth the completed floor.

**NOTE**

If liner is authorized, attach the hook and pile fasteners on the bottom of the liner to the hook and pile fasteners on the perimeter of the floor.

**REMOVING FLOOR FOR TYPE I & TYPE II TENT SYSTEM****NOTE**

If the MGPTS is equipped with a liner, disconnect the hook and pile fasteners on the bottom of the liner from the hook and pile fasteners on the perimeter of the floor.

1. Go inside tent. At the perimeter disconnect the snaps on the floor sections from the d-rings on the fabric of the tent.
2. Disconnect the hook and pile fasteners between the mid floor section and the two end floor sections.
3. Fold the mid floor section and transport it out of the tent.
4. Fold each end floor section and remove from the tent.

**END OF WORK PACKAGE**



**OPERATOR'S AND UNIT MAINTENANCE  
MODULAR GENERAL PURPOSE TENT SYSTEM (MGPTS)  
NSN 8340-01-491-1392, NSN 8340-01-477-1390  
LINER - OPERATION UNDER USUAL CONDITIONS**

### INSTALLING LINER IN TYPE I TENT SYSTEM

This section applies to the Type I MGPTS only. If you are installing the liner in a Type II MGPTS go to the section labeled Installing Liner in Type II Tent System.

**Table 1. Quantity of liner sections for the Type I MGPTS.**

	Quantity		
	Small	Medium	Large
End Section	2	2	2
Mid Section	0	1	2

1. Identify each liner section required. For the medium MGPTS you will need two end liner sections and one mid liner section.
  - a. If floor is installed, loosen side pole's guy ropes to reduce tension
  - b. Separate and peel back floor prior to removing Y-Poles.
  - c. If Y-Poles are already installed, lower and remove them from the tent before installing liner.



### WARNING

Liner sections are heavy. Always lift with your legs not your back. Failure to observe this warning may result in back injury.

2. Transport the mid liner section **(1)** into the tent.
3. Unfold and position the mid liner section in the middle of the tent. Position the mid liner section with the wire connectors and snaps around perimeter facing up.
4. Align the door on the mid liner section with the door on the tent fabric.
5. Transport one end liner section into the tent.

**INSTALLING LINER IN TYPE I TENT SYSTEM - continued**

6. Unfold the end liner section **(2)** and position the end liner section next to the mating end of the mid liner section. Position the end liner section **(2)** with the wire connectors and snaps around perimeter facing up.

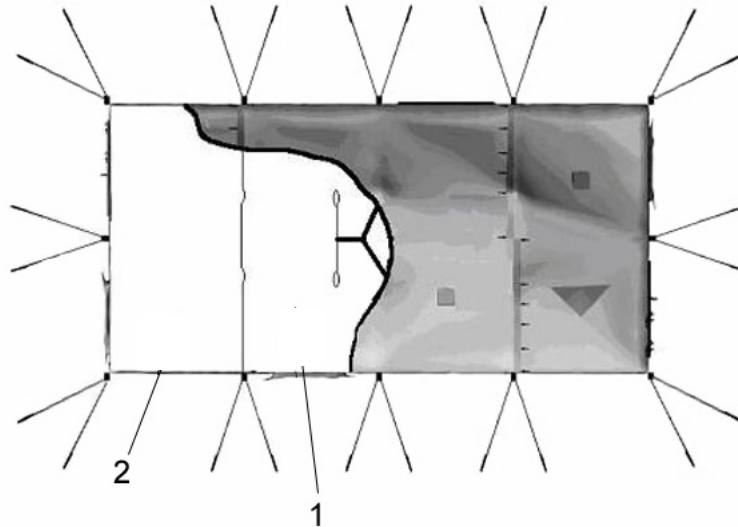

7. Bring the end liner section and mid liner section together at one edge. Start attaching the hook and pile fasteners at the bottom of the liners.
8. Continue attaching the hook and pile fastener up the liners to the point where the roof material begins. At this point connect the ring and snap.
9. Continue attaching the hook and pile fastener up the roof cloth to the peak of the liner.
10. Locate the adjustable straps **(3)** at the peak of the liner. Pull the adjustable straps **(3)** with snap assembly through grommets **(4)** on top of other liner.

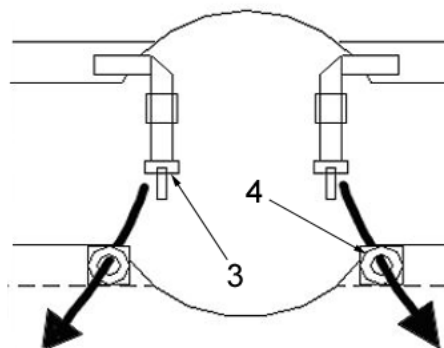

**INSTALLING LINER IN TYPE I TENT SYSTEM - continued**

11. Continue attaching the hook and pile fastener across the top of the liner between the peaks. The hook and pile fasteners will be reversed half way between the peaks.
12. Locate the adjustable straps **(3)** at the second peak and pull the adjustable straps with snap assembly through the grommets **(4)** on top of liner.
13. Complete attaching the hook and pile fastener down the opposite side.
14. Locate the d-rings on the inside of the tent fabric at the peaks. Connect adjustable straps to the corresponding d-rings on either side of the peak fitting, this will allow the Y-Pole arms to fit through the opening in the liner.

**NOTE**

If lights are authorized, pull all light support hangers through the opening in liner at the peak fittings.

15. Find the adjustable straps in the middle of the liner section at the split. Pull the adjustable straps through the grommet on the other side flap.
16. Locate the d-rings on inside of peak for mid tent section, connect adjustable straps to the corresponding d-rings on either side of peak fitting.
17. Transport another end liner section into the tent.
18. Unfold the end liner section **(2)** and position the end liner section next to the mating end of the mid liner section. Position the end liner section **(2)** with the wire connectors and snaps around perimeter facing up.
19. Bring the end liner section and mid liner section together at one edge. Start attaching the hook and pile fasteners at the bottom of the liners.
20. Continue attaching the hook and pile fastener up the liners to the point where the roof material begins. At this point connect the ring and snap.
21. Continue attaching the hook and pile fastener up the roof cloth to the peak of the liner.
22. Locate the adjustable straps at the peak of the liner. Pull the adjustable straps with snap assembly through grommets on top of other liner.
23. Continue attaching the hook and pile fastener across the top of the liner between the peaks. The hook and pile fasteners will be reversed half way between the peaks.
24. Locate the adjustable straps at the second peak and pull the adjustable straps with snap assembly through the grommets on top of liner.

**INSTALLING LINER IN TYPE I TENT SYSTEM - continued****NOTE**

If lights are authorized, pull all light support hangers through the opening in liner at the peak fittings.

25. Complete attaching the hook and pile fastener down the opposite side.
26. Locate the d-rings on the inside of the tent fabric at the peaks. Connect adjustable straps to the corresponding d-ring on either side of peak fitting, this will allow the Y-Pole arms to fit through the opening in the liner.
27. Locate the curtain rope around the inside perimeter of the tent fabric.
28. Starting at one corner liner, connect the snaps on the liner to the curtain rope in that corner. Continue this for all liner snaps and wire connectors around the liner perimeter.
29. The snaps at the corners and lace lines are adjustable. Adjust these straps as necessary to dress out the liner.

**NOTE**

Liner side walls can be rolled and secured using the tie straps at liner eave if desired.

**NOTE**

If Y-Pole were installed before, re-install Y-Poles now.

**NOTE**

If floor is authorized, attach hook and pile fasteners on the bottom of the liner to the hook and pile fasteners on the perimeter of the floor.

**REMOVING LINER IN TYPE I TENT SYSTEM**

This section applies to the Type I MGPTS only. If you are installing the liner in a Type II MGPTS go to the section labeled Removing Liner in Type II Tent System.

1. Loosen all guy ropes around perimeter of tent.
2. Starting at one end of the tent, lower all the Y-Poles.
3. Fold the Y-arms and remove from tent. Repeat for remaining Y-Poles.

**REMOVING LINER IN TYPE I TENT SYSTEM - continued****NOTE**

If the MGPTS is equipped with a plenum, remove the plenum first before striking liner. Refer to WP 0008 00 for instructions.

**NOTE**

If the MGPTS is equipped with a lights, remove the lights first before striking liner. Refer to WP 0004 00 for instructions.

4. Unroll rolled up liner section at tent opening (if secured with tie straps). Go inside tent. If a floor is installed, disconnect the hook and pile fasteners between the bottom of the liner and perimeter of the floor.
5. Starting at one corner, locate the curtain rope around the inside perimeter of the tent fabric. Disconnect the snaps and wire connectors on the liner from the curtain rope. Continue this for all liner snaps around the perimeter.
6. Disassemble Liner.

**NOTE**

Liner may be left in one assembly.

- a. Begin at one intersection of an end section and mid section, begin detaching the hook and pile fastener up the wall. Disconnect the ring and snap.
- b. At the peak fittings disconnect the adjustable straps from the d-rings.
- c. Pull the adjustable strap out of the grommets.
- d. Continue detaching the hook and pile fastener across the top of the liner. Disconnect the ring and snap.
- e. After the hook and pile fastener has been disconnected, fold the end section and remove from the tent.
- f. At the other intersection of an end section and mid section, begin detaching the hook and pile fastener up the wall. Disconnect the ring and snap.
- g. At the peak fittings disconnect the adjustable straps from the d-rings.
- h. Pull the adjustable strap out of the grommets.
- i. Continue detaching the hook and pile fastener across the top of the liner.
- j. Disconnect the ring and snap

**REMOVING LINER IN TYPE I TENT SYSTEM - continued**

- k. After the hook and pile fastener has been disconnected, fold the end section and remove from the tent.
- l. For the mid section, at the peak fittings disconnect the adjustable straps from the d-rings.
- m. Pull the adjustable strap out of the grommets.
- n. Fold the mid section and remove from the tent.

**INSTALLING LINER IN TYPE II TENT SYSTEM**

This section applies to the Type II MGPTS only. If you are installing the liner in a Type I MGPTS go to the section labeled Installing Liner in Type I Tent System.

**Table 2. Quantity of liner sections for the Type II MGPTS.**

	Quantity		
	Small	Medium	Large
End Section	2	2	2
Mid Section	0	1	2

**NOTE**

If the frame arch assemblies and end poles are raised, they must be lowered before the liner can be installed and re-raised after, refer to WP 0005 00 for lowering and raising instructions.

1. Identify each liner section required. For the medium MGPTS you will need two end liner sections and one mid liner section.



**WARNING**

Liner sections are heavy. Always lift with your legs not your back. Failure to observe this warning may result in back injury.

2. Transport the mid liner section (1) into the tent.



**INSTALLING LINER IN TYPE II TENT SYSTEM - continued**

3. Unfold and position the mid liner section in the center of the tent.
4. Position the mid liner section with the wire connectors and snaps around perimeter facing up.

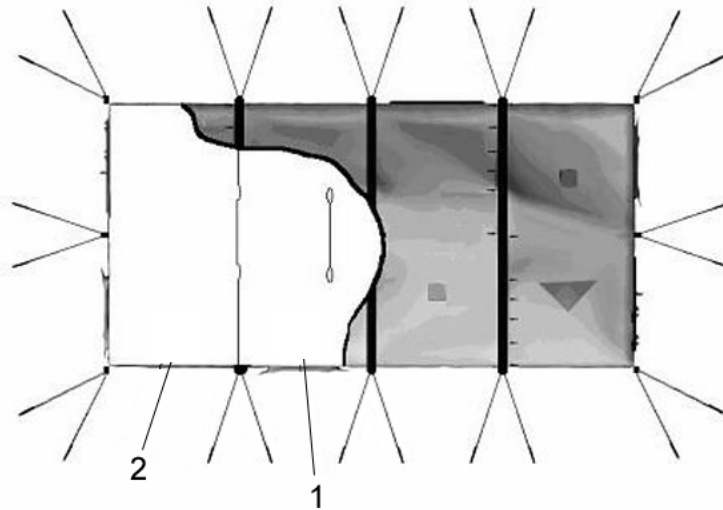

5. Transport one end liner section (2) into the tent.
6. Unfold the end liner section (2) and position the end liner section (2) next to one end of the mid liner section (1). Position the end liner section (2) with the wire connectors and snaps around perimeter facing up.
7. Bring the end liner section (2) and mid liner section (1) together at one edge.
8. Start attaching the hook and pile fasteners at the bottom of the liners.
9. Continue attaching the hook and pile fastener up the liners where the roof material begins.
10. Connect the ring and snap at this point.
11. Continue attaching the hook and pile fastener up the roof cloth to the peak of the liner.
12. Locate the adjustable straps (3) at the peak of the liner.
13. Pull the adjustable straps (3) with snap assembly through grommets (4) on top of liner.

## INSTALLING LINER IN TYPE II TENT SYSTEM - continued

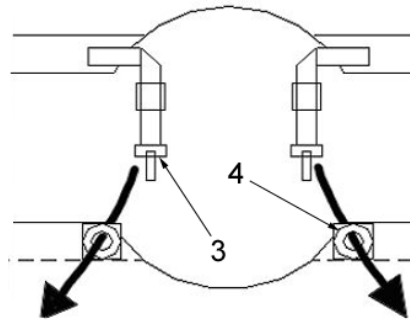

14. Continue attaching the hook and pile fastener across the top of the liner between the peaks. The hook and pile fastener will be reversed half way between the peaks.
15. Locate the two adjustable straps **(3)** at the second peak and pull the adjustable strap with snap assembly through the grommet **(4)** on top of liner.
16. Locate the d-rings on the inside of the tent fabric at the peaks. Connect adjustable straps to the d-rings.
17. Complete attaching the hook and pile fastener down the opposite side.
18. Find the adjustable straps at the mid liner section split. Pull the adjustable straps through the grommet on the other side flap.
19. Locate the d-rings on inside of peak for mid tent section, connect adjustable straps to the corresponding d-rings on either side of peak fitting.
20. Transport the other end liner section **(2)** into the tent.
21. Unfold the end liner section **(2)** and position the end liner section **(2)** next to the other end of the mid liner section **(1)**. Position the end liner section **(2)** with the wire connectors and snaps around perimeter facing up.
22. Bring the end liner section **(2)** and mid liner section **(1)** together at one edge. Start attaching the hook and pile fastener at the bottom of the liners.
23. Continue attaching the hook and pile fastener up the liners to the point where the roof material begins. At this point connect the ring and snap.
24. Continue attaching the hook and pile fastener up the roof cloth to the peak of the liner.
25. Locate the adjustable straps at the peak of the liner. Pull the adjustable straps with snap assembly through grommets on top of liner.

**INSTALLING LINER IN TYPE II TENT SYSTEM - continued**

26. Continue attaching the hook and pile fastener across the top of the liner between the peaks. The hook and pile fastener will be reversed half way between the peaks.
27. Locate the adjustable strap at the second peak and pull the adjustable strap with snap assembly through the grommet on top of liner.
28. Locate the d-rings on the inside of the tent fabric at the peaks. Connect adjustable straps to the d-rings.
29. Complete attaching the hook and pile fastener down the opposite side.
30. Locate the curtain rope around the inside perimeter of the tent fabric.
31. Starting at one corner of the liner, connect the snaps on the liner to the curtain rope in that corner.
32. Continue this for all liner snaps and wire connectors around the liner.
33. The snaps at the corners and lace lines are adjustable. Adjust these straps as necessary to dress out the liner.
34. At tent opening roll up a liner section and tie with tie straps.

**NOTE**

If floor is authorized, attach hook and pile fasteners on the bottom of the liner to the hook and pile fasteners on the perimeter of the floor.

**REMOVING LINER IN TYPE II TENT SYSTEM**

This section applies to the Type II MGPTS only. If you are installing the liner in a Type I MGPTS go to the section labeled Removing Liner in Type I Tent System.

**NOTE**

If the MGPTS is equipped with a plenum, remove the plenum first before removing liner. Refer to WP 0008 00 for instructions.

**NOTE**

If the MGPTS is equipped with lights, remove the lights first before removing liner. Refer to WP 0005 for instructions.

1. Unroll rolled-up liner section at tent opening (if secured with tie straps). Go inside tent. If a floor is installed, disconnect the hook and pile fasteners between the bottom of the liner and perimeter of the floor.

**REMOVING LINER IN TYPE II TENT SYSTEM - continued**

2. Starting at one corner, locate the curtain rope around the inside perimeter of the tent fabric. Disconnect the snaps and wire connectors on the liner from the curtain rope. Continue this for all liner snaps and wire connectors around the perimeter.
3. Disassemble liner.

**NOTE**

Liner may be left in one assembly.

- a. Begin at one intersection of an end section and mid section, begin detaching the hook and pile fastener up the wall. Disconnect the snap from ring at eave.
- b. At the peak fittings disconnect the adjustable straps from the D-rings.
- c. Pull the adjustable straps out of the grommets.
- d. Continue detaching the hook and pile fastener across the top of the liner. Disconnect the ring and snap.
- e. After the hook and pile fastener has been disconnected, fold the end section and remove from the tent.
- f. At the other intersection of an end section and mid section, begin detaching the hook and pile fastener up the wall. Disconnect the snap from ring at eave.
- g. At the peak fittings disconnect the adjustable straps from the d-rings.
- h. Pull the adjustable straps out of the grommets.
- i. Continue detaching the hook and pile fastener across the top of the liner. Disconnect the ring and snap.
- j. After the hook and pile fastener has been disconnected, fold the end section and remove from the tent.
- k. For the mid section at the peak fittings, disconnect the adjustable straps from the d-rings.
- l. Pull the adjustable straps out of the grommets.
- m. Fold the mid section and remove from the tent.

**END OF WORK PACKAGE**

**OPERATOR'S AND UNIT MAINTENANCE  
MODULAR GENERAL PURPOSE TENT SYSTEM (MGPTS)  
NSN 8340-01-523-0826, NSN 8340-01-523-0828  
PLENUM - OPERATION UNDER USUAL CONDITIONS**

**GENERAL**

The Plenum Assembly will always include an end cap and an inlet, only the number of horizontal assemblies varies by MGPTS size as follows:

**Table 1. MGPTS Plenum Horizontal Assembly.**

MGPTS size	Number of Horizontal Assemblies required.
Small	1
Medium	2
Large	3

**INSTALL**

1. Find the inlet assembly **(1)**, horizontal assembly **(2)** and end cap assembly **(3)**.

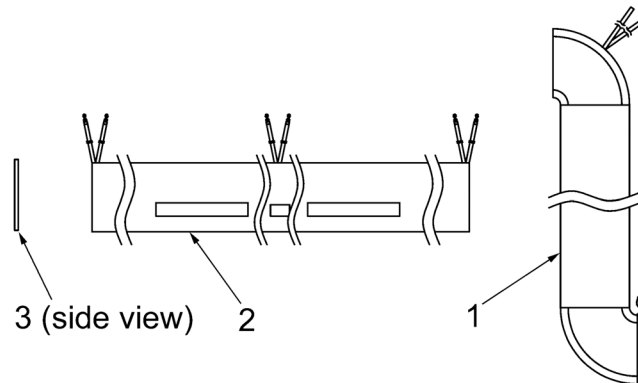

2. Layout the plenum inlet assembly **(1)**, horizontal assembly **(2)** and end cap **(3)** on the floor length-wise inside the MGPTS tent.

**INSTALL - continued****NOTE**

Make sure drawstring (4) is on top.

3. Place drawstring (4) on inlet assembly (1) around ductwork and tighten.
4. Using the hook and pile fasteners on the horizontal assembly (2) and the inlet assembly (1), align the black line on inlet hook and pile fastener to the top strap of the horizontal assembly.
5. Connect the hook and pile fasteners (5) at the ends of both tubes, so that the tubes overlap each other.

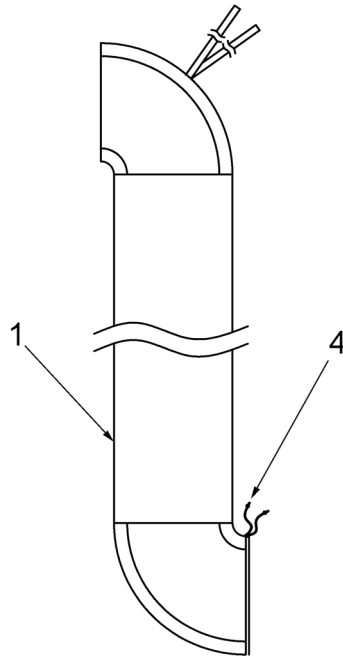

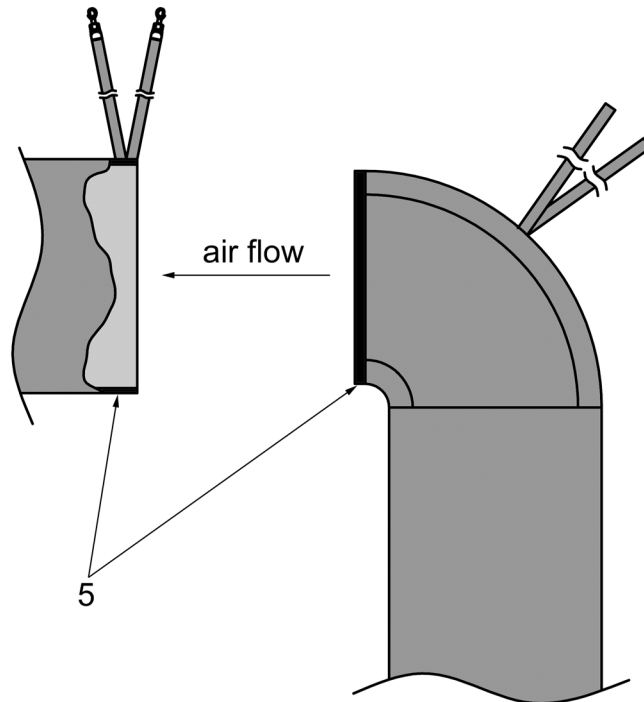

**NOTE**

If you are using more than one horizontal assembly (2), use the hook and pile fasteners to connect the sections together. All of the straps (6) should be on one side of the connected assemblies; you will use the straps with snaps to hang the plenum from the roof.

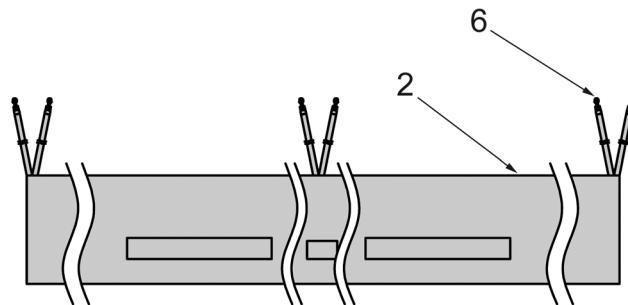

6. Connect end cap (3) at end of last horizontal assembly (2).
7. Starting at inlet side of tent, grasp end of completed assembly (with cap) and lay down center of tent making sure tubes are not twisted and ties with snaps are on top.

**NOTE**

Untie wind straps on end poles, and then lower end poles to assist with next step.

8. Starting at top of plenum inlet assembly **(1)**, connect straps to curtain rope along the end wall and through the opening in the liner (if authorized). Make sure the plenum is not twisted.

If you are using the Type II tent go to step 10.

9. The plenum will hang between the y-arms of the Type I MGPTS.

**NOTE**

There will be an additional set of straps that won't be attached to the d-ring.

10. Using the strap and snap assemblies on horizontal assemblies, connect one strap to each D-ring at the peaks **(8)** of the tent to form a V, making sure that the plenum is not twisted. Refer to Type I or Type II drawing depending on model.

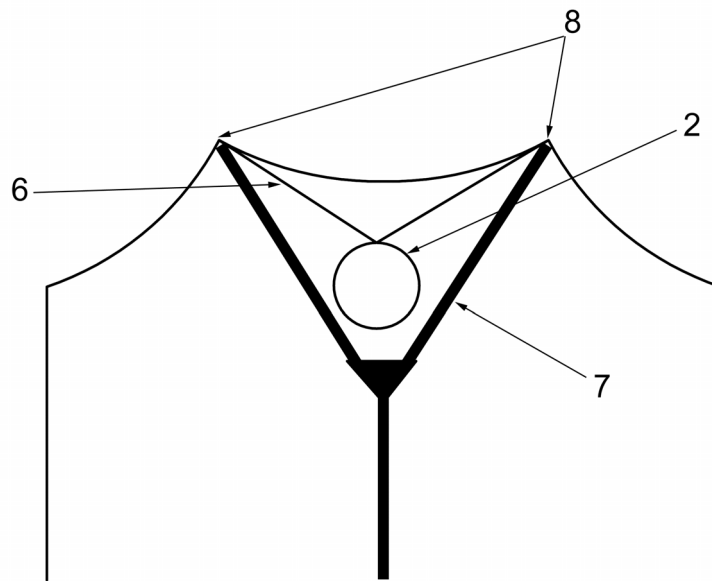

**MGPTS -- TYPE I**

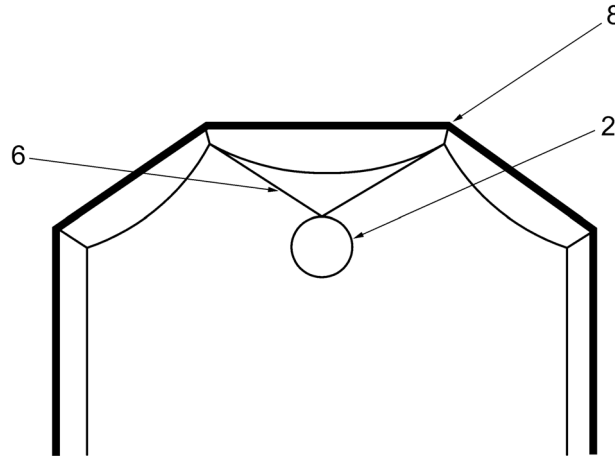

**MGPTS -- TYPE II**

11. At the end cap, attach the snaps and straps to the ring at the peak of the gable end of the tent.

**NOTE**

If you are using the Type I MGPTS, re-raise the y poles now. Refer to WP 0004 00 for instructions.

**REMOVE****NOTE**

Loosen end pole guy ropes to reduce tension.

**NOTE**

If you are using the Type I MGPTS and the floor is being used, loosen side pole guy ropes to reduce tension. Then separate and peel back floor prior to removing y poles.

1. Disconnect each strap from the horizontal assembly from each d-ring.
2. If using the Type I tent; remove the plenum assembly from between the arms of the y pole.
3. At top of plenum inlet assembly, disconnect the straps from curtain rope along the end wall.
4. At the inlet drawstring, loosen drawstring and remove plenum assembly from ductwork.
5. Disconnect end cap at end of last horizontal assembly.
6. Disconnect hook and pile fasteners from the plenum assembly sections.
7. Fold plenum assembly sections and return to plenum assembly bags.

**END OF WORK PACKAGE**



---

**OPERATOR'S AND UNIT MAINTENANCE**  
**MODULAR GENERAL PURPOSE TENT SYSTEM (MGPTS)**  
NSN 8340-01-456-3633, NSN 8340-01-456-3628, NSN 8340-01-456-3674  
NSN 8340-01-516-6860, NSN 8340-01-516-6861, NSN 8340-01-516-6863  
NSN 8340-01-491-1507, NSN 8340-01-491-1515, NSN 8340-01-491-1479  
NSN 8340-01-516-6859, NSN 8340-01-516-6864, NSN 8340-01-516-6865  
**OPERATION UNDER UNUSUAL CONDITIONS**

---

## OPERATION UNDER UNUSUAL CONDITIONS

### General

While it is not possible to prepare for all of the unusual conditions to which the MGPTS will be exposed, the following information should be helpful during unusual climatic conditions.

### Operation in High Winds



---

## WARNING

---

All guy ropes must be staked down. Failure to properly stake and tie down tent may result in injury to personnel and damage to equipment.

1. Replace wooden stakes with ground anchor kit. If ground anchor kit is not available use 36-inch wood stakes.
2. Close and fasten all windows, doors and pass-throughs.
3. Check all tent stakes and tighten guy ropes.
4. Secure base of tent, by placing sandbags or snow on mudskirts, position outside of tent.

---

**OPERATION UNDER UNUSUAL CONDITIONS - continued****NOTE**

If mud skirts are being used, reverse the direction of all rope loops by pulling rope loop out of grommet and insert rope loop through other side of grommet. Stake rope loops by inserting finger into rope loop, twist rope loop to form a figure 8. Place the two newly created loops around finger. Insert stake into both loops and drive stake into ground.

**Wet Climate**

1. If heavy rain is expected, or MGPTS is going to be set up for a long period of time dig a perimeter trench around outside of tent.
2. Dry all MGPTS components before packing.

**NOTE**

Small amounts of moisture may accumulate in the upper corners of the MGPTS when rain rate is 4 inches per hour and 65-mi/h winds are present. Moisture accumulation will be small to measure. Users are advised that the MGPTS may not offer a completely sealed environment for some extreme conditions.

**Soft Soil**

---

**CAUTION**

---

If the soil is soft additional stakes are required. Failure to properly stake in soft soil may result in injury to personnel and damage to equipment

1. Install an additional wood stake **(1)** at each guy rope location six inches from the original stake **(2)**.
2. Connect the guy rope **(3)** to a third wood stake **(4)**, which should be placed horizontally behind the two stakes **(1)** and **(2)**.

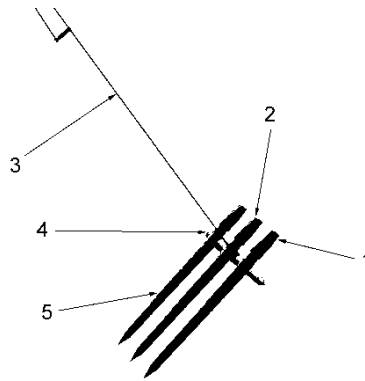
**OPERATION UNDER UNUSUAL CONDITIONS - continued**

3. If necessary add a fourth stake **(5)** at each guy rope location.

**Operation in Snow/Extreme Cold**

1. Inspect all roof vents for snow and ice accumulations. If accumulations exist, clear all snow and ice from roof vent.
2. Gently push up on roof from inside the MGPTS to remove snow that may have piled up.
3. Before erecting the MGPTS in snow, gently tamp snow down to provide a firm surface on which to set up.
4. When erecting the MGPTS in severe cold, use care in handling and unfolding fabric components. Rough handling can cause component damage.

---

**OPERATION UNDER UNUSUAL CONDITIONS - continued**

---

**WARNING**

---

Do not use non-vented type heaters. The use of non-vented heaters will cause the accumulation of Carbon monoxide gas. Carbon monoxide gas is not visible and it has no smell. If symptoms of headache, dizziness, fatigue, nausea, or irregular breathing occur, move affected personnel to fresh air. Failure to comply with this warning may result in personal injury or death.



---

**WARNING**

---

All fuel burning heaters consume oxygen. Adequate ventilation must be maintained at all times. Keep roof vents clear of snow, ice or debris. Open doors, windows, flaps, and hook and pile fastener wall closures as needed to introduce sufficient fresh air to replace oxygen consumed by heaters. If symptoms of headache, dizziness, fatigue, nausea, or irregular breathing occur, move affected personnel to fresh air. Failure to comply with this warning may result in personal injury or death.



---

**WARNING**

---

Stay alert to weather conditions and adjust all guy ropes at tent slips as required, before snow, ice, or water weight damages tent or injures personnel.

**Extreme Heat**

1. Roll up end walls and window/roof section fabric to provide maximum ventilation.
2. Open weather flaps on both sides of the tent sections.
3. Untie and disconnect hook and pile fastener connection as high as eave.

**OPERATION UNDER UNUSUAL CONDITIONS - continued**

4. Open the entranceway door and tie back.
5. Fold and roll fabric underneath itself and towards top. Tie with tie tape.

**Nuclear, Biological, and Chemical (NBC) Decontamination**

1. If Chemical or Biological contamination is expected, close all MGPTS openings such as windows, doors, stovepipe openings and pass-throughs.

**NOTE**

Perform unit level decontamination of the MGPTS only under supervision of unit NBC personnel.

2. If MGPTS is set up, decontaminate the fabric around the entranceway area of nuclear, chemical or biological contamination by applying Supertropical Bleach (STB) slurry or brushing with hot soapy water.
3. Prepare slurry by mixing approximately equal parts of water with STB. Scrub slurry into fabric.
4. Remove slurry promptly with brushes (Work package 0042 00, Table 1, Item 1) and liberal quantities of hot water and soap (Work package 0042 00, Table 1, Item 5) then rinse with clear water.

**NOTE**

STB slurry may leave a harmless, white chalky residue. This is not a cause for concern.

5. Decontaminate the remaining sections of the MGPTS by natural methods. Expose the erected tent to the effects of weather and aeration for approximately 2-3 days.

**CAUTION**

Heavy concentration of Decontamination Solution (DS2) is harmful to the MGPTS fabric. A fine spray mist is recommended. Do not scrub with mop or broom.

**NOTE**

DS2 will cause some change in fabric color.

Aeration is not effective against V-agents. If contaminated by V-agent entire MGPTS must be decontaminated with DS2 slurry.

**END OF WORK PACKAGE**





**CHAPTER 3**  
**OPERATOR MAINTENANCE INSTRUCTIONS**  
**FOR**  
**MODULAR GENERAL PURPOSE TENT SYSTEM (MGPTS)**



---

**OPERATOR INSTRUCTIONS**  
**MODULAR GENERAL PURPOSE TENT SYSTEM (MGPTS)**  
**NSN 8340-01-456-3633, NSN 8340-01-456-3628, NSN 8340-01-456-3674**  
**NSN 8340-01-516-6860, NSN 8340-01-516-6861, NSN 8340-01-516-6863**  
**NSN 8340-01-491-1507, NSN 8340-01-491-1515, NSN 8340-01-491-1479**  
**NSN 8340-01-516-6859, NSN 8340-01-516-6864, NSN 8340-01-516-6865**  
**SERVICE UPON RECEIPT**

---

**UNPACKING**

The Unit Maintenance technician must inspect equipment before it is used. The technician will make the following checks when equipment is unpacked:

1. Inspect equipment for damage incurred during shipment. If equipment has been damaged in shipment, report damage on SF 364 (Report of Discrepancy).
2. Check equipment against packing list to see if shipment is complete.
3. Report all discrepancies in accordance with DA Pam 738-750.
4. Check to see whether equipment has been modified.
5. Service damaged equipment as necessary, using Unit Maintenance procedures to restore equipment to operable condition.

**END OF WORK PACKAGE**



---

**OPERATOR MAINTENANCE  
MODULAR GENERAL PURPOSE TENT SYSTEM (MGPTS)  
NSN 8340-01-456-3633, NSN 8340-01-456-3628, NSN 8340-01-456-3674  
NSN 8340-01-516-6860, NSN 8340-01-516-6861, NSN 8340-01-516-6863  
NSN 8340-01-491-1507, NSN 8340-01-491-1515, NSN 8340-01-491-1479  
NSN 8340-01-516-6859, NSN 8340-01-516-6864, NSN 8340-01-516-6865  
PREVENTIVE MAINTENANCE CHECK AND SERVICES (PMCS), INTRODUCTION**

---

## INTRODUCTION

Preventive Maintenance Checks and Services (PMCS) are performed to keep the MGPTS in good operating condition. The checks are used to find, correct, or report problems. Unit personnel are to do the PMCS jobs as shown in the PMCS tables. PMCS are done every day the MGPTS is operated, using the PMCS table.

"Before" refers to PMCS inspection intervals, before using the MGPTS.

"During" refers to PMCS inspection intervals, while using the MGPTS.

"After" refers to PMCS inspection intervals, after using the MGPTS.

If you find something wrong when performing PMCS, fix it using maintenance procedures (WP 0012 00 through WP 0014 00 and WP 0016 00 through WP 0018 00).

The right-hand column of the PMCS table lists conditions that make the MGPTS not fully mission capable. Write up the faults not fixed on DA Form 2404 for unit support maintenance. For further information on how to use this form, see DA 738-750.

If tools required to perform PMCS are not listed in procedure, notify your supervisor.

## INSPECTION

Look for signs of trouble. Using your senses helps here. You can feel, smell, hear, or see many problems that can be eliminated before they get worse. Inspect to see if items are in good condition. Are components correctly installed and secured? Is any damage to the fabric or frame components visible? Correct any faults or notify unit support maintenance.

**INSPECTION - continued**

There are some common items to check on the MGPTS. These include the following:

- Fabric sections, including windows, and personnel doors.
- Pole sections, including attached ropes.
- Lights, including power cords.
- Transport Covers and Bags

**SERVICING**

Proper cleaning of the MGPTS components is an integral part of maintenance. It can help prevent possible problems in the future, so make it a habit to clean all MGPTS components whenever necessary. The fabric sections must be dry before being folded and stored. Clean all MGPTS fabric components with a brush and mild soapy water (WP 0042 00, Table 1) and then let fabric dry.

Be sure to observe all special information and notes that appear in your table.

**END OF WORK PACKAGE**

**OPERATOR MAINTENANCE**  
**MODULAR GENERAL PURPOSE TENT SYSTEM (MGPTS)**  
 NSN 8340-01-456-3633, NSN 8340-01-456-3628, NSN 8340-01-456-3674  
 NSN 8340-01-516-6860, NSN 8340-01-516-6861, NSN 8340-01-516-6863  
 NSN 8340-01-491-1507, NSN 8340-01-491-1515, NSN 8340-01-491-1479  
 NSN 8340-01-516-6859, NSN 8340-01-516-6864, NSN 8340-01-516-6865  
**PMCS, INCLUDING LUBRICATION INSTRUCTIONS**

Table 1. Fabric Sections.

Item No.	Interval	Item to be Checked/ Serviced	Procedure	Equipment Not Ready/Available If:
1	Before During After	Roof and Wall	Inspect roof fabric and wall fabric <b>(1)</b> for punctures, holes, and tears.	Roof or wall fabric has punctures, holes, or tears.
2	Before During After	Buckles	Ensure all quick disconnect fasteners <b>(2)</b> are present and serviceable.	Quick disconnect fasteners are missing or not serviceable.

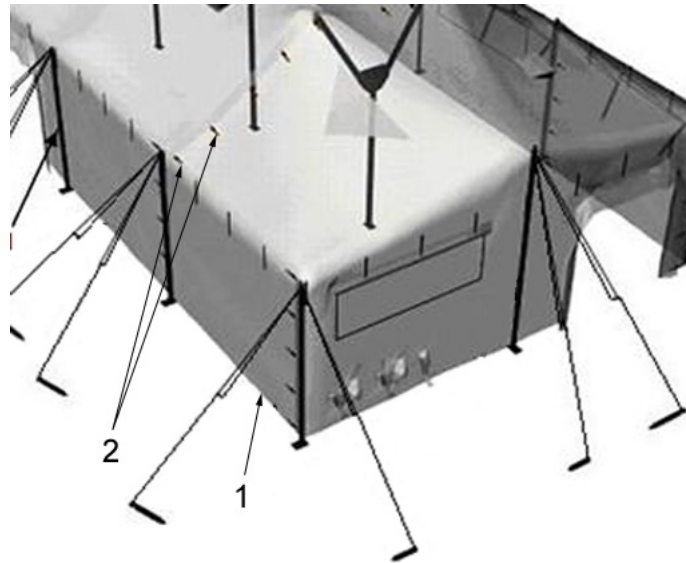

**Table 2. Frame and Pole Assemblies.**

Item No.	Interval	Item to Checked/ Serviced	Procedure	Equipment Not Ready/Available If:
1	Before During After	Tent Pole (End) (1)	Inspect end pole tubing and base for bends, cracks and dents.	Pole components have bends or cracks.
2	Before During After	Tent Pole (Side) (2)	Inspect side pole tubing and base for bends, cracks and dents.	Pole components have bends or cracks.
3	Before During After	Tent Pole (Y) (3)	Ensure all peak fittings are present.  Inspect for dents, cracks or bends.	Peak fittings are Missing.  Cracks or bends are present.
4	Before During After	Frame Arch Assembly (4)	Ensure all Hangar Pin Assemblies are present.  Inspect arch assembly for bends, cracks or dents.	Hangar Pin Assemblies missing.  Arch is bent or cracked.
5	Before During After	Guy Ropes (5)	Ensure all guy ropes are installed, serviceable. Inspect for fraying.	Guy ropes not installed, frayed or not serviceable
6	During	Stakes (6)	Ensure stakes are firmly in ground.  Inspect stakes for cracks or splits in the wood.	Stakes are missing, or not serviceable.  Stakes are cracked or split.



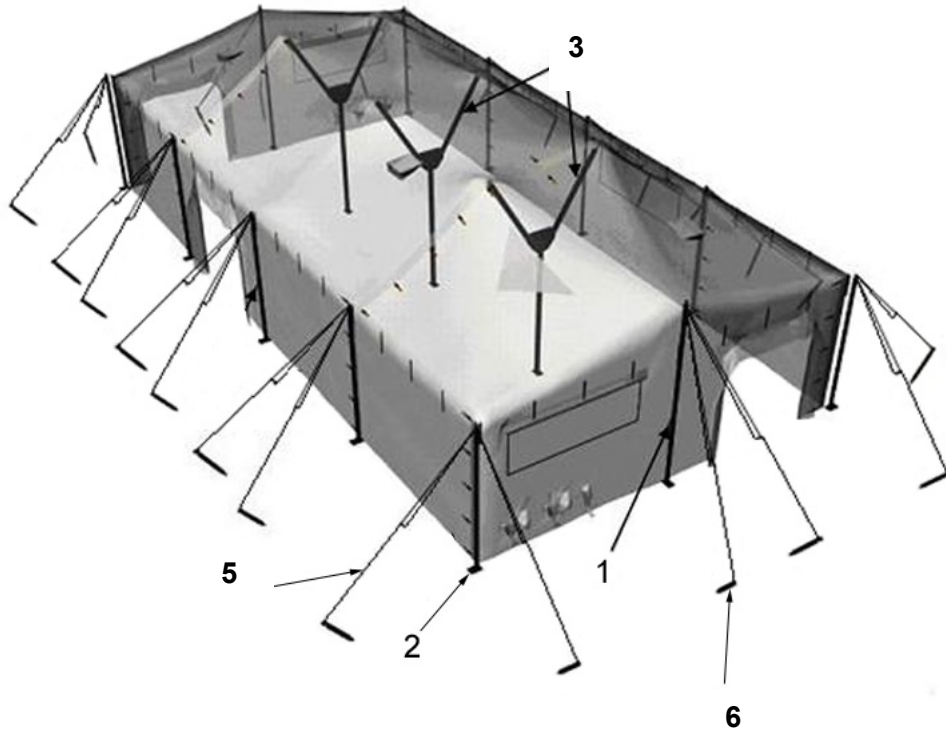

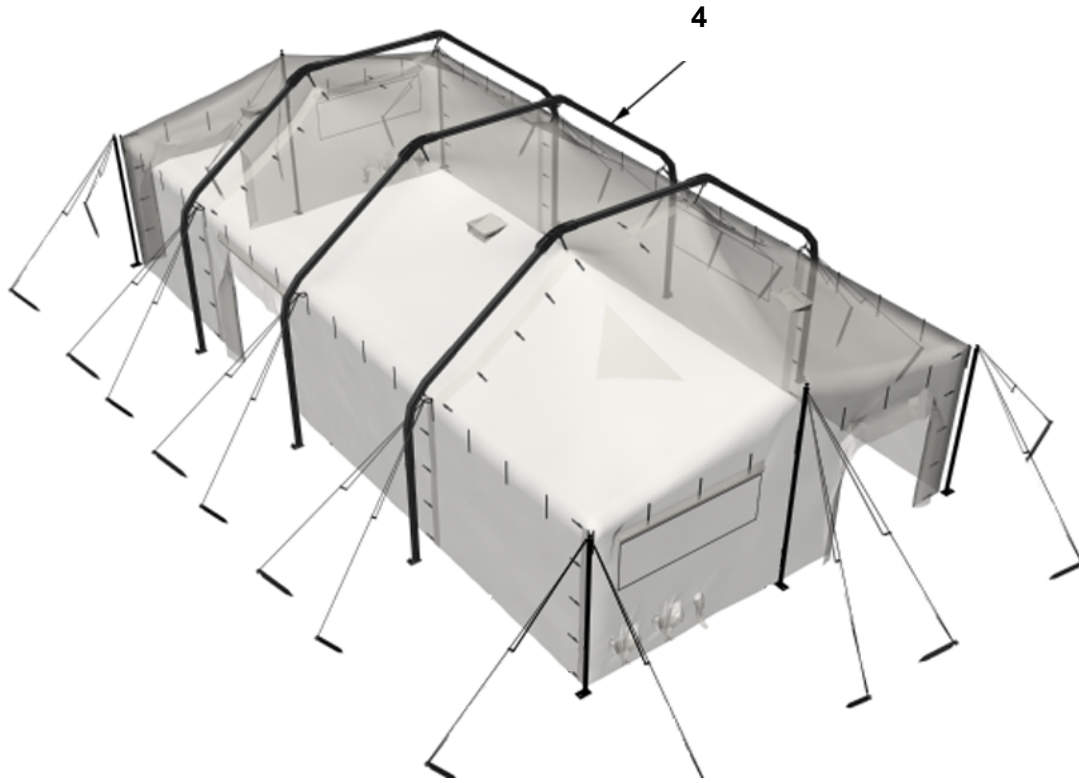

Table 3. Floor.

Item No.	Interval	Item to Checked/ Serviced	Procedure	Equipment Not Ready/Available If:
1	Before During After	End Sections	Inspect fabric (1) for punctures, holes, and tears.	Fabric has punctures, holes, or tears.
2	Before During After	Mid Sections	Inspect fabric (2) for punctures, holes, and tears.	Fabric has punctures, holes, or tears.

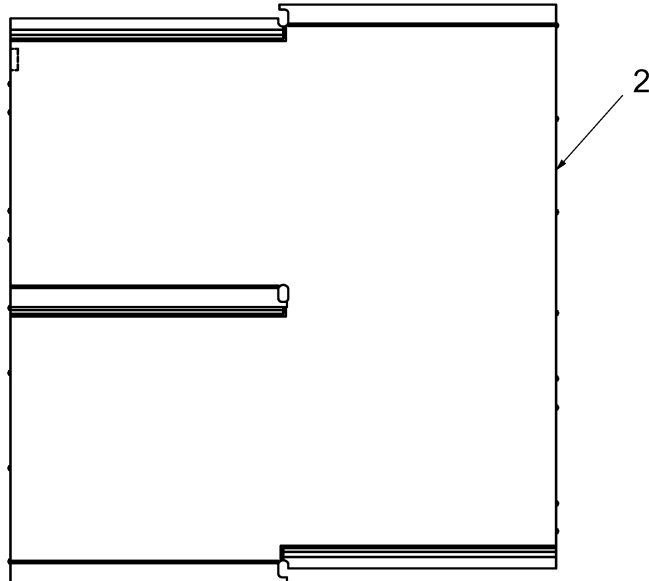
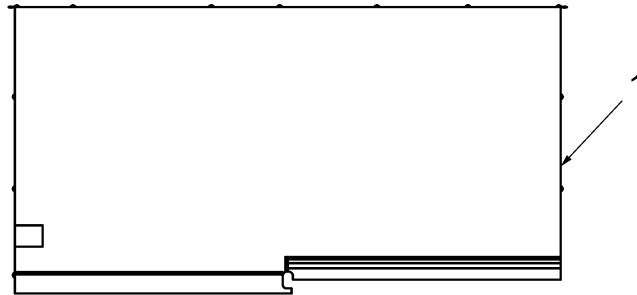

Table 4. Liner.

Item No.	Interval	Item to Checked/ Serviced	Procedure	Equipment Not Ready/Available If:
1	Before During After	End Sections	Inspect fabric (1) for punctures, holes, and tears.	Fabric has punctures, holes, or tears.
2	Before During After	Mid Sections	Inspect fabric (2) for punctures, holes, and tears.	Fabric has punctures, holes, or tears.

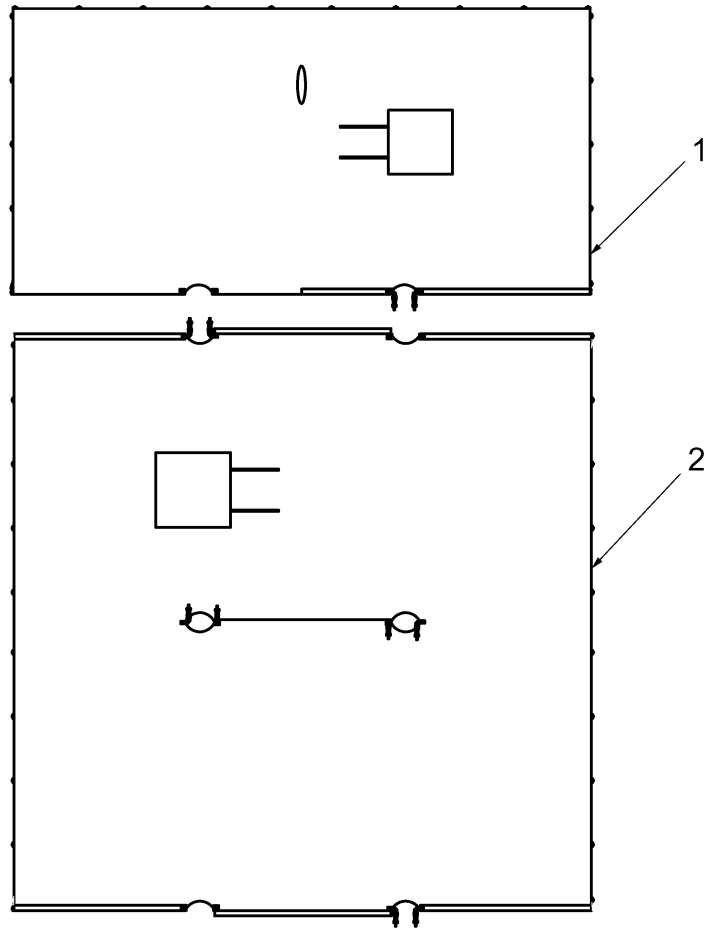
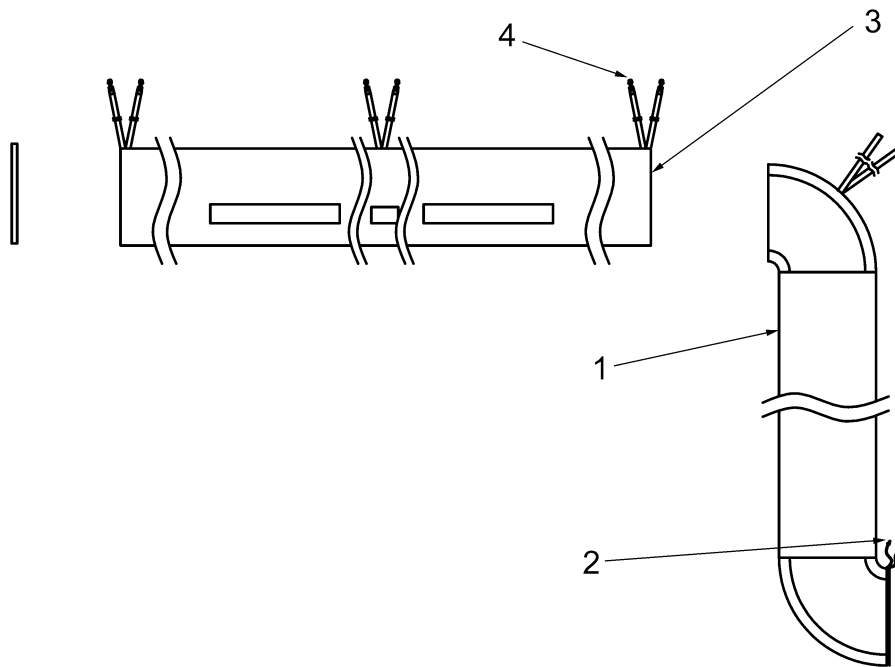

Table 5. Plenum.

Item No.	Interval	Item to Checked/ Serviced	Procedure	Equipment Not Ready/Available If:
1	Before During After	Fabric	Inspect fabric (1) for punctures, holes, and tears.	Fabric has punctures, holes, or tears.
2	Before During After	Drawstrings	Inspect drawstrings (2) for broken string, or missing.	Drawstring is missing or broken.
3	Before During After	Hook and pile fasteners	Ensure all hook and pile fasteners (3) are present.	Hook and pile fasteners are missing or not serviceable.
4	Before During After	Tie straps	Ensure all tie straps (4) are present and serviceable.	Tie Straps missing or not serviceable.



There are no replacement parts required for these PMCS procedures.

**END OF WORK PACKAGE**



---

**OPERATOR MAINTENANCE**  
**MODULAR GENERAL PURPOSE TENT SYSTEM (MGPTS)**  
**FABRIC ASSEMBLY END MODULE AND FABRIC ASSEMBLY MID MODULE**  
**NSN 8340-01-456-3633, NSN 8340-01-456-3628, NSN 8340-01-456-3674**  
**NSN 8340-01-516-6860, NSN 8340-01-516-6861, NSN 8340-01-516-6863**  
**NSN 8340-01-491-1507, NSN 8340-01-491-1515, NSN 8340-01-491-1479**  
**NSN 8340-01-516-6859, NSN 8340-01-516-6864, NSN 8340-01-516-6865**  
**REPAIR AND REPLACE**

---

**INITIAL SETUP:****Equipment Condition**

MGPTS not in use.

**Tools**

Repair Kit, Tentage (Item 10, WP 0040 00)

**Personnel Required**

One

**Materials/Parts****References**WP 0013 00, WP 0016 00, WP 0017 00,  
WP 0018 00, FM 10-16

---

**REPAIR****NOTE**

Repair is limited to fabric repair.

**NOTE**

When repairing punctures you can use the new less expensive repair kit (green or tan) (WP 0040 00, table 1) using the procedures in WP 0013 00 or the older/more expensive tentage repair kit (WP 0041 00, table 1) with the procedures in WP 0016 00. Refer to WP 0017 00 for hand stitching instructions.

1. Repair punctures up to 1/8 in. (3.2mm) in diameter and rips, tears and holes not larger than 4 inches in diameter with the repair kit.
2. Whenever possible, repairs to fabric requiring stitching should be accomplished by sewing machine at the unit support level. Consult FM 10-16 for more guidance on repairing fabric.
3. Repair grommets according to the procedures in WP 0018 00.

**REPLACE**

1. The MGPTS tent must be struck before the end or mid section can be replaced. Refer to WP 0004 00 if you are using the Type I MGPTS or WP 0005 00 if you are using the Type II MGPTS for striking procedures.
2. The end or mid section can now be replaced.

**END OF WORK PACKAGE**



---

**OPERATOR MAINTENANCE**  
**MODULAR GENERAL PURPOSE TENT SYSTEM (MGPTS)**  
**FABRIC ASSEMBLY END MODULE AND FABRIC ASSEMBLY MID MODULE**  
NSN 8340-01-456-3633, NSN 8340-01-456-3628, NSN 8340-01-456-3674  
NSN 8340-01-516-6860, NSN 8340-01-516-6861, NSN 8340-01-516-6863  
NSN 8340-01-491-1507, NSN 8340-01-491-1515, NSN 8340-01-491-1479  
NSN 8340-01-516-6859, NSN 8340-01-516-6864, NSN 8340-01-516-6865  
**REPAIR**

---

**INITIAL SETUP:****Equipment Condition**

MGPTS not in use.

**Tools**

Repair Kit, Tentage (Green) (Item 9, WP 0040 00)

Repair Kit, Tentage (Tan) (Item 10, WP 0040 00)

**Personnel Required**

One

**Materials/Parts**

---

**REPAIR**

To repair punctures up to 1/8 in. (3.2 mm) in diameter and rips, tears and holes not larger than 4 inches in diameter with the Repair Kit:

1. Make sure fabric area to be repaired is clean with alcohol rub and dry.
2. Cut adhesive patch **(1)** at least 1 in. larger than the damaged fabric area **(2)** (in the same color) in all directions. When cutting, round the corners of the patch.

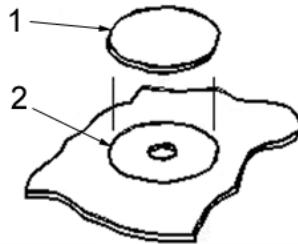

**REPAIR - continued**

3. Place the damaged fabric area **(2)** on a flat surface, or place a piece of softwood under the damaged fabric area **(2)**.
4. Peel backing off adhesive patch **(1)** to expose adhesive.
5. Use firm pressure to apply adhesive patch **(1)** over damaged fabric **(2)** and pay particular attention to the edges of the patch.

**END OF WORK PACKAGE**

---

**OPERATOR MAINTENANCE**  
**MODULAR GENERAL PURPOSE TENT SYSTEM (MGPTS)**  
**TENT POLE (END), TENT POLE (SIDE), TENT POLE (Y) AND FRAME ARCH ASSEMBLY**  
**NSN 8340-01-477-9525, NSN 8340-01-477-9566, NSN 8340-01-477-9570**  
**REPAIR AND REPLACE**

---

**INITIAL SETUP:****Equipment Condition**

MGPTS not in use.

**Tools**

Repair Kit, Tentage (Green) (Item 9, WP 0040 00)

Repair Kit, Tentage (Tan) (Item 10, WP 0040 00)

**Personnel Required**

One to Repair.

Four to Replace.

**Materials/Parts**

---

**REPAIR****NOTE**

Repair is limited to repair of the guy ropes.

To repair the guy rope assembly for the end pole or side pole:

1. Cut the damaged guy rope **(1)** from the pole body **(2)**.
2. Using the guy rope assembly included with the Repair Kit, untie the knot at the end of the rope, not the knot next to the loop **(3)** at the other end.
3. Making sure that the dog bone **(4)** and loop **(3)** are together slip the free end through the ring **(5)** at the top of the pole body **(2)**.
4. Insert the free end of the rope through the free opening of the dog bone **(4)** and tie with an appropriate knot.

## REPAIR - continued

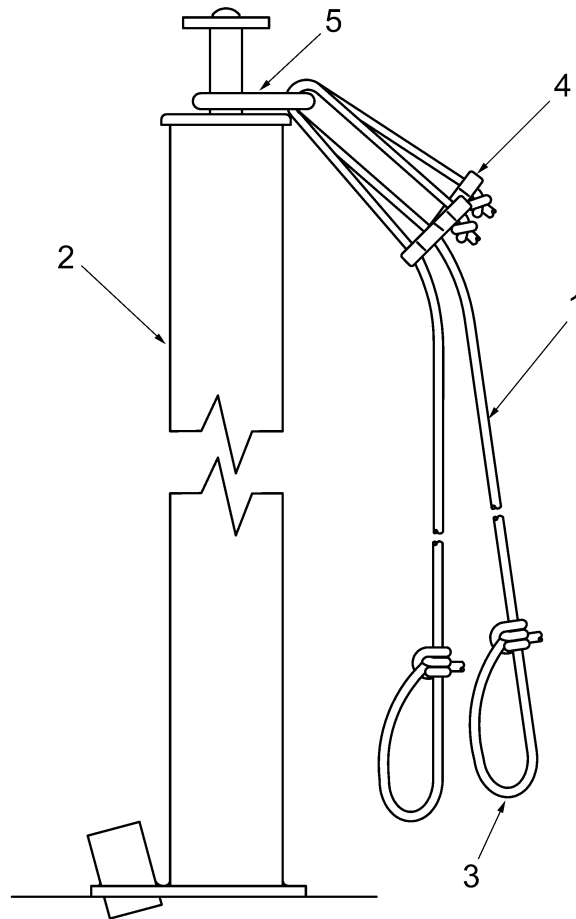

To repair the guy rope assembly on the frame arch assembly:

1. Cut the damaged guy rope (1) from the frame arch (2).
2. Using the guy rope assembly included with the Repair Kit, untie the knot at the end of the rope, not the knot next to the loop at the other end.
3. Making sure that the dog bone (3) and loop are together slip the free end through the ring (4) on the frame arch (2).
4. Insert the free end of the rope through the free opening of the dog bone (3) and tie with an appropriate knot.

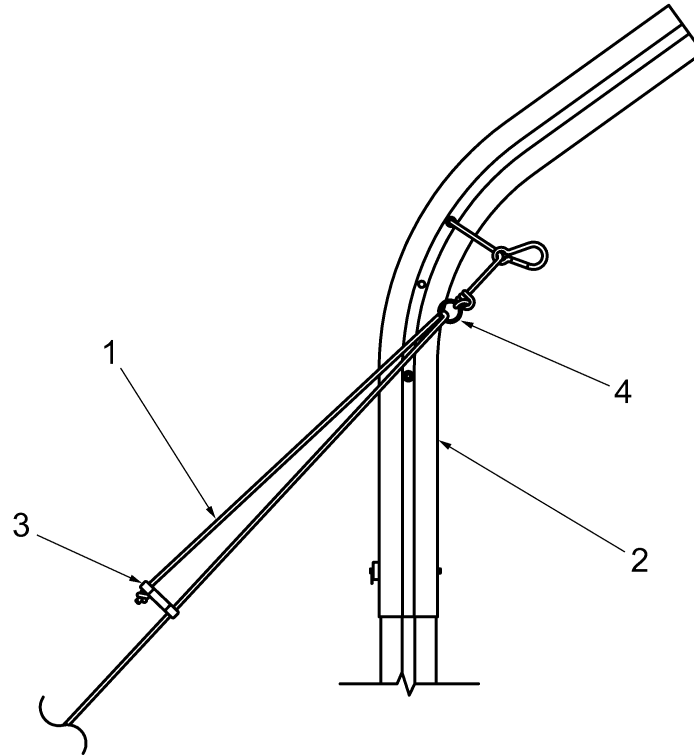
**REPAIR - continued****REPLACE**

Before the end pole (or side pole or y pole or frame arch) can be replaced, the MGPTS must be struck. Refer to WP 0005 00 for striking instructions for the Type II MGPTS; refer to WP 0004 00 for striking instructions for the Type I MGPTS.

The side pole (or end pole or y pole or frame arch) can now be replaced.

**END OF WORK PACKAGE**



**CHAPTER 4**  
**UNIT MAINTENANCE INSTRUCTIONS**  
**FOR**  
**MODULAR GENERAL PURPOSE TENT SYSTEM (MGPTS)**





---

**UNIT MAINTENANCE**  
**MODULAR GENERAL PURPOSE TENT SYSTEM (MGPTS)**  
**FABRIC ASSEMBLY END MODULE AND FABRIC ASSEMBLY MID MODULE**  
NSN 8340-01-477-9569, NSN 8340-01-491-1465,  
NSN 8340-01-477-9567, NSN 8340-01-491-1463  
**REPAIR**

---

**INITIAL SETUP:**

**Equipment Condition**  
MGPTS not in use.

**Tools**  
Tentage Repair Kit (WP 0040 00)

**Personnel Required**  
One

**Materials/Parts**  
Fabric, Green (Item 6, WP 0037 00)  
Fabric, Tan (Item 7, WP 0037 00)

---

**REPAIR**

To repair punctures up to 1 1/8 in. (3.2 mm) in diameter and rips, tears and holes not larger than 4" in diameter with the Tentage repair kit:

1. Make sure fabric area to be repaired is clean and dry.
2. Obtain a clean, round patch **(1)** from bulk material that is at least 1 inch larger than the damaged fabric area **(2)** (in the same color) in all directions.

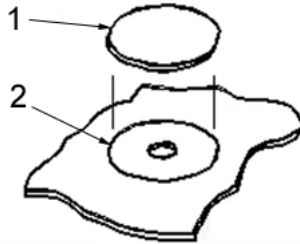

**REPAIR - continued**

3. Place the damaged fabric area **(2)** on a flat surface, or place a piece of softwood under the damaged fabric area **(2)**.
4. Center patch **(1)** over damaged fabric area **(2)**. Draw a circle on fabric **(2)** around patch **(1)**, then remove patch **(1)**.
5. Clean damaged fabric area **(2)** inside circle.

**WARNING**

The adhesive has a high alcohol content and is highly flammable. Use only in well ventilated areas away from open flame. Do not smoke. In case of dizziness, leave area immediately and allow to ventilate. Failure to observe this warning may result in injury or death.

6. Place patch **(1)** face-down over circle. Coat patch evenly with adhesive **(3)**, allowing adhesive to overlap onto fabric to form an adhesive circle. Remove patch **(1)** and set aside with adhesive side up.

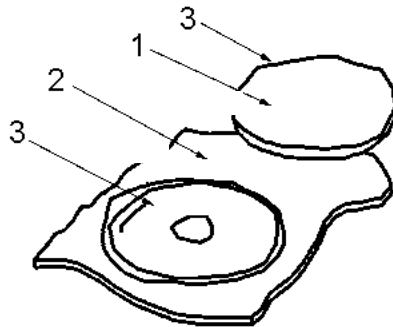

7. Coat damaged fabric **(2)** with adhesive **(3)** inside circle. Allow adhesive **(3)** on patch and adhesive circle to dry.
8. Apply a second coat of adhesive **(3)** to patch and inside adhesive circle
9. Wait ten to fifteen minutes for adhesive **(3)** to become tacky to touch.

**REPAIR - continued**

10. Center patch (1) over circle, adhesive side down, and press the two sticky surfaces together.
11. Using hand roller (4), press excess adhesive (3) and air bubbles from under patch. Roll first in one direction, then in opposite direction.

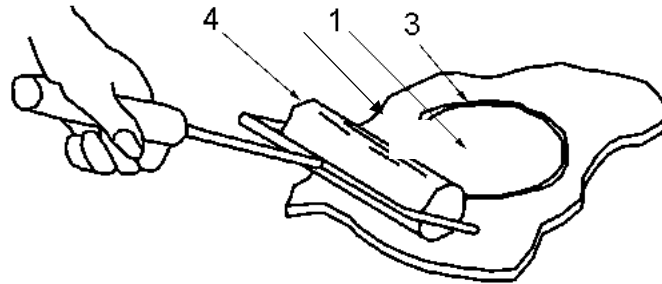

12. Using tongue depressor (5), apply a small amount of adhesive (3) to edge of patch (1). Run tongue depressor (5) around patch (1) to seal and prevent fraying.

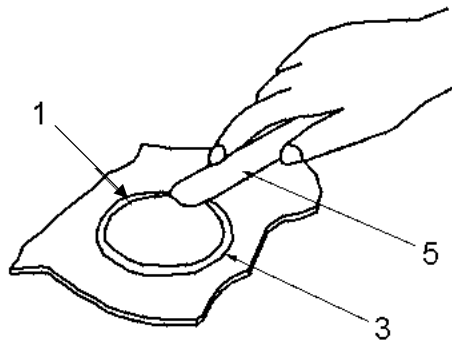

13. Allow adhesive (3) to dry.

**END OF WORK PACKAGE**



---

**UNIT MAINTENANCE**  
**MODULAR GENERAL PURPOSE TENT SYSTEM (MGPTS)**  
**FABRIC ASSEMBLY END MODULE AND FABRIC ASSEMBLY MID MODULE**  
NSN 8340-01-477-9569, NSN 8340-01-491-1465,  
NSN 8340-01-477-9567, NSN 8340-01-491-1463  
**REPAIR**

---

**INITIAL SETUP:****Equipment Condition**

MGPTS not in use.

**Tools**

Tentage Repair Kit (WP 0040 00)

**Personnel Required**

One

**Materials/Parts**

---

**REPAIR**

To repair using hand stitching:

1. Make sure fabric is clean and dry.
2. Preparing needle and thread.

**NOTE**

If you use two-strand thread you will need twice as much; if you use four-strand, you will need four times as much.

- a. Estimate amount of thread required to complete stitching and cut thread to length.
- b. Wax thread **(1)** by pressing between thumb and beeswax **(2)** and drawing entire length over beeswax **(2)**.

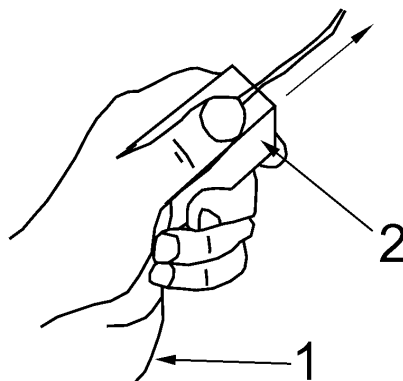

**REPAIR - continued**

- c. Thread sailmaker's needle (3) with waxed thread to form a single, two, or four-strand thread as follows:
- (1) One end and push the loop through the eye of the needle.
  - (2) Two-strand. To make a double strand thread, pull the thread through the needle until the needle is at the midpoint of the single thread strand.
  - (3) Four-strand. To form four-strand thread, bend a length of thread in half and insert the loop end into the eye of the needle, pulling it through so that the eye is at the midpoint of the double strand of thread.

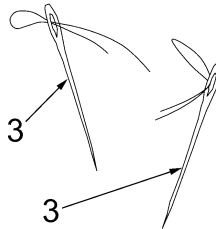

- d. Twist the strand together and re-wax the entire length of thread.

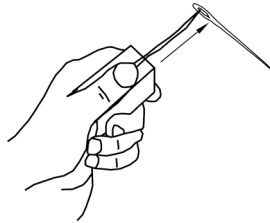

- e. Tie knot at far end of the single, two, or four-strand thread.

3. **Hand stitches.** There are five common hand stitches used to mend fabric in different situations. Choose the one that most closely resembles the repair you are making.

- a. **Flat Stitch.** This stitch is used as a temporary fastening until machine repairs can be made. Pass the needle over and under an equal amount of material, each successive entering the material from the opposite side.

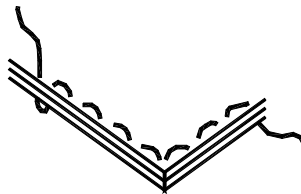

## REPAIR - continued

- b. **Round Stitch.** This stitch is used to handwork grommets. Insert the materials at right angles to the edge of materials and bring around edge before making the next stitch.

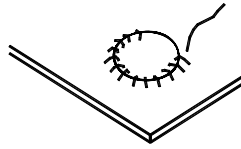

- c. **Overcast Stitch.** This stitch is used to apply a hand-sewn patch. Insert the needle through the material at an angle so that it comes out to one side and ahead of the point of insertion, and bring the cord over to the original line of insertion before making the next stitch.

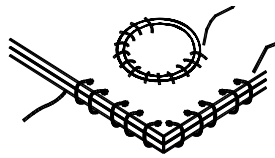

- d. **Backstitch.** This Stitch is used to secure an open seam. It is so named because the needle is always set back one half of a stitch length into the last stitch made. Make two small stitches in the same place to secure the cord ends. Continue by inserting the needle into the middle of the preceding stitch and bringing it out on the same side of the material one stitch length in advance of preceding stitch.

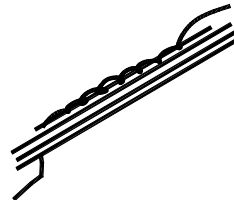

- e. **Fishbone Stitch.** This stitch is used to join edges of a tear unit; a patch can be applied. Insert needle between two edges of material to be sewn together. Take a diagonal stitch from one side toward the other bringing the needle out between the two edges. Repeat this operation on the opposite side, and continue alternating stitches from side to side. To keep the stitches uniform, hold the edges smoothly together. Make stitches firmly, but do not pull them tight enough to pucker the fabric.

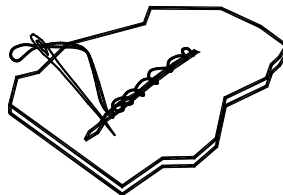

END OF WORK PACKAGE





---

**UNIT MAINTENANCE**  
**MODULAR GENERAL PURPOSE TENT SYSTEM (MGPTS)**  
**FABRIC ASSEMBLY END MODULE AND FABRIC ASSEMBLY MID MODULE**  
**NSN 8340-01-477-9569, NSN 8340-01-491-1465,**  
**NSN 8340-01-477-9567, NSN 8340-01-491-1463**  
**REMOVE/ INSTALL, REPAIR**

---

**INITIAL SETUP:****Equipment Condition**

MGPTS not in use.

**Tools**

Tentage Repair Kit (WP 0040 00)

**Personnel Required**

One

**Materials/Parts****References**

WP 0013 00, WP 0016 00, WP 0017 00

**REMOVE**

To remove a grommet, if still attached, cut the damaged grommet from the fabric.

**NOTE**

If fabric repair is required, refer to WP 0013 00 for repair instructions using the cheaper Repair Kit (green or tan) (Items 9 or 10, WP 0040 00) or you can use the instructions in WP 0016 00 for repair with the more expensive Tentage Repair Kit (WP 0040 00). Refer to WP 0017 00 for hand stitching instructions.

**REPAIR**

To repair a grommet:

**NOTE**

A die-inserted grommet consists of two brass parts. The male half, called a barrel **(1)**, is smooth. The female half, called a washer **(2)**, has spurs that grip the fabric.

1. Insert a grommet.

**REPAIR - continued**

2. Position fabric **(3)** face up on end grain surface of softwood lumber.

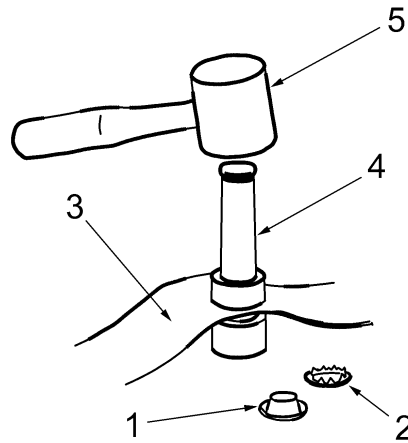

3. Using a size 5 cutting punch **(4)** for a size 4 grommet (or a size 6 cutting punch for a size 5 grommet) and a rawhide mallet **(5)**; cut a grommet hole in patch by hitting top of cutting punch with rawhide mallet.

**INSTALL**

To install a grommet:

1. Insert grommet barrel **(1)** into hole of fabric **(2)** from the underside.
2. Place fabric and bottom (flat) part of grommet barrel on grommet die.
3. Place the grommet washer **(3)**, spurs down, over grommet barrel.
4. Insert setting punch **(4)** into grommet barrel and hold in place.

**INSTALL - continued****NOTE**

When parts are clinched properly, the edge of the grommet barrel has a smooth roll.

5. Hit top of setting punch with mallet (5) hard enough to clinch the parts to fabric without damaging grommet or fabric.

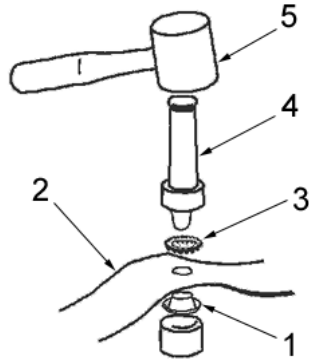
**END OF WORK PACKAGE**



**CHAPTER 5**

**SUPPORTING INFORMATION**  
**FOR**  
**MODULAR GENERAL PURPOSE TENT SYSTEM (MGPTS)**



---

**OPERATOR'S AND UNIT MAINTENANCE**  
**MODULAR GENERAL PURPOSE TENT SYSTEM (MGPTS)**  
**NSN 8340-01-456-3633, NSN 8340-01-456-3628, NSN 8340-01-456-3674**  
**NSN 8340-01-516-6860, NSN 8340-01-516-6861, NSN 8340-01-516-6863**  
**NSN 8340-01-491-1507, NSN 8340-01-491-1515, NSN 8340-01-491-1479**  
**NSN 8340-01-516-6859, NSN 8340-01-516-6864, NSN 8340-01-516-6865**  
**REFERENCES**

---

**SCOPE**

This work package lists all field manuals, forms, pamphlets, technical manuals, army regulations, military specifications, and military standards referenced in the manual.

**DA Pamphlets**

The Army Maintenance Management System (TAMMS)	DA PAM 738-750
--	----------------

**Federal Standards**

Colors	FED-STD-595
Stitches, Seams and Stitching	FED-STD-751

**Field Manuals**

NBC Decontamination	FM 3-5
First Aid for Soldiers	FM 21-11
General Fabric Repair	FM 10-16

**Forms**

Discrepancy in Shipment Report	SF 361
Equipment Inspection and Maintenance Worksheet	DA Form 2404
Quality Deficiency Report	SF 368
Recommended Changes to Equipment Technical Publications	DA Form 2028-2
Report of Discrepancy	SF 364
Report of Packaging and Handling Deficiencies	SF 362

**Military Standards**

Palletizing Unit Loads	MIL-STD-147
Quality of Wood Members for Containers and Pallets	MIL-STD-731
Treatment and Painting of Material	MIL-STD-704

**Technical Manuals**

Camouflage Screen and Screen Support Systems	TM 5-1080-200-13&P
Destruction of Army Material to Prevent Enemy Use	TM 750-244-3
Administrative Storage of Equipment	TM 740-90-1
Preservation, Packaging, and Packing of Military Supplies and Equipment	TM 38-230-2

**Miscellaneous**

Army Medical Department Expendable Items	CTA 8-100
Expendable/Durable Items	CTA 50-970



---

**OPERATOR'S AND UNIT MAINTENANCE  
MODULAR GENERAL PURPOSE TENT SYSTEM (MGPTS)  
NSN 8340-01-456-3633, NSN 8340-01-456-3628, NSN 8340-01-456-3674  
NSN 8340-01-516-6860, NSN 8340-01-516-6861, NSN 8340-01-516-6863  
NSN 8340-01-491-1507, NSN 8340-01-491-1515, NSN 8340-01-491-1479  
NSN 8340-01-516-6859, NSN 8340-01-516-6864, NSN 8340-01-516-6865  
MAINTENANCE ALLOCATION CHART (MAC), INTRODUCTION**

---

## INTRODUCTION

### The Army Maintenance System MAC

This introduction provides a general explanation of all maintenance and repair functions authorized at various maintenance levels under the Standard Army Maintenance System concept.

The MAC (immediately following the introduction) designates overall authority and responsibility for the performance of maintenance functions on the identified end item or component. The application of the maintenance functions to the end item or component shall be consistent with the capacities and capabilities of the designated maintenance levels, which are shown on the MAC in column (4) as:

Unit - includes two subcolumns, C (operator/crew) and O (unit) maintenance.

Direct Support - includes an F subcolumn.

General Support - includes an H subcolumn.

Depot - includes a D subcolumn.

The tools and test equipment requirements (immediately following the MAC) list the tools and test equipment (both special tools and common tool sets) required for each maintenance function as referenced from the MAC.

The remarks (immediately following the tools and test equipment requirements) contain supplemental instructions and explanatory notes for a particular maintenance function.

**INTRODUCTION - continued****Maintenance Functions**

Maintenance functions are limited to and defined as follows:

1. **Inspect.** To determine the serviceability of an item by comparing its physical, mechanical and/or electrical characteristics with established standards through examination (e.g., by sight, sound, or feel). This includes scheduled inspection and gagings and evaluation of cannon tubes.
2. **Test.** To verify serviceability by measuring the mechanical, pneumatic, hydraulic, or electrical characteristics of an item and comparing those characteristics with prescribed standards on a scheduled basis, i.e., load testing of lift devices and hydrostatic testing of pressure hoses.
3. **Service.** Operations required periodically to keep an item in proper operating condition, e.g., to clean (includes decontaminate, when required), to preserve, to drain, to paint, or to replenish fuel, lubricants, chemical fluids, or gases. This includes scheduled exercising and purging of recoil mechanisms.
4. **Adjust.** To maintain or regulate, within prescribed limits, by bringing into proper position, or by setting the operating characteristics to specified parameters.
5. **Align.** To adjust specified variable elements of an item to bring about optimum or desired performance
6. **Calibrate.** To determine and cause corrections to be made or to be adjusted on instruments of test, measuring, and diagnostic equipment used in precision measurement. Consists of comparisons of two instruments, one of which is a certified standard of known accuracy, to detect and adjust any discrepancy in the accuracy of the instrument being compared.
7. **Remove/Install.** To remove and install the same item when required to perform service or other maintenance functions. Install may be the act of emplacing, seating, or fixing into position a spare, repair part, or module (component or assembly) in a manner to allow the proper functioning of an equipment or system.
8. **Replace.** To remove an unserviceable item and install a serviceable counterpart in its place. "Replace" is authorized by the MAC and assigned maintenance level is shown as the third position code of the Source, Maintenance and Recoverability (SMR) code.
9. **Repair.** The application of maintenance services, including fault location/troubleshooting, removal/installation, disassembly/assembly procedures, and maintenance actions to identify troubles and restore serviceability to an item by correcting specific damage, fault, malfunction, or failure in a part, subassembly, module (component or assembly), end item, or system.

**NOTE**

The following definitions are applicable to the "repair" maintenance function:

Services - Inspect, test, service, adjust, align, calibrate, and/or replace.

Fault location/troubleshooting - The process of investigating and detecting the cause of equipment malfunctioning; the act of isolating a fault within a system or Unit Under Test (UUT).

Disassembly/assembly - The step-by-step breakdown (taking apart) of a spare/functional group coded item to the level of its least component, that is assigned an SMR code for the level of maintenance under consideration (i.e., identified as maintenance significant).

Actions - Welding, grinding, riveting, straightening, facing, machining, and/or resurfacing.

10. Overhaul. That maintenance effort (service/action) prescribed to restore an item to a completely serviceable/operational condition as required by maintenance standards in appropriate technical publications. Overhaul is normally the highest degree of maintenance performed by the Army. Overhaul does not normally return an item to like new condition.
11. Rebuild. Consists of those service/actions necessary for the restoration of unserviceable equipment to a like new condition in accordance with original manufacturing standards. Rebuild is the highest degree of materiel maintenance applied to Army equipment. The rebuild operation includes the act of returning to zero those age measurements (e.g., hours/miles) considered in classifying Army equipment/components.

**Explanation of Columns in the MAC**

Column (1) - Group Number. Column (1) lists FGC numbers, the purpose of which is to identify maintenance significant components, assemblies, subassemblies, and modules with the Next Higher Assembly (NHA).

Column (2) - Component/Assembly. Column (2) contains the item names of components, assemblies, subassemblies, and modules for which maintenance is authorized.

Column (3) - Maintenance Function. Column (3) lists the functions to be performed on the item listed in column (2). (For a detailed explanation of these functions refer to "Maintenance Functions" outlined above.)

Column (4) - Maintenance Level. Column (4) specifies each level of maintenance authorized to perform each function listed in column (3), by indicating work time required (expressed as manhours in whole hours or decimals) in the appropriate subcolumn. This work time figure represents the active time required to perform that maintenance function at the indicated level of maintenance. If the number or complexity of the tasks within the listed maintenance function varies at different maintenance levels, appropriate work time figures are to be shown for each level. The work time figure represents the average time required to restore an item (assembly, subassembly, component, module, end item or system) to a serviceable condition under typical field operating conditions. This time includes preparation time (including any necessary disassembly/assembly time), troubleshooting/fault location time, and quality assurance time in addition to the time required to perform the specific tasks identified for the maintenance functions authorized in the MAC. The symbol designations for the various maintenance levels are as follows:

- C - Operator or crew maintenance
- O - Unit maintenance
- F - Direct support maintenance
- L - Specialized Repair Activity (SRA)
- H - General support maintenance
- D - Depot maintenance

#### **NOTE**

The "L" maintenance level is not included in column (4) of the MAC. Functions to this level of maintenance are identified by a work time figure in the "H" column of column (4), and an associated reference code is used in the REMARKS column (6). This code is keyed to the remarks and the SRA complete repair application is explained here.

Column (5) - Tools and Equipment Reference Code. Column (5) specifies, by code, those common tool sets (not individual tools), common Test, Measurement and Diagnostic Equipment (TMDE), and special tools, special TMDE and special support equipment required to perform the designated function. Codes are keyed to the entries in the tools and test equipment table.

Column (6) – Remarks Code. When applicable, this column contains a letter code, in alphabetical order, which is keyed to the remarks table entries.

#### **Explanation of Columns in the Tools and Test Equipment Requirements**

Column (1) — Tool or Test Equipment Reference Code. The tool or test equipment reference code correlates with a code used in column (5) of the MAC.

Column (2) — Maintenance Level. The lowest level of maintenance authorized to use the tool or test equipment.

Column (3) — Nomenclature. Name or identification of the tool or test equipment.

Column (4) — National Stock Number (NSN). The NSN of the tool or test equipment.

Column (5) — Tool Number. The manufacturer's part number, model number, or type number.

**Explanation of Columns in the Remarks**

Column (1) — Remarks Code. The code recorded in column (6) of the MAC.

Column (2) — Remarks. This column lists information pertinent to the maintenance function being performed as indicated in the MAC.



**OPERATOR'S AND UNIT MAINTENANCE  
 MODULAR GENERAL PURPOSE TENT SYSTEM (MGPTS)  
 NSN 8340-01-456-3633, NSN 8340-01-456-3628, NSN 8340-01-456-3674  
 NSN 8340-01-516-6860, NSN 8340-01-516-6861, NSN 8340-01-516-6863  
 NSN 8340-01-491-1507, NSN 8340-01-491-1515, NSN 8340-01-491-1479  
 NSN 8340-01-516-6859, NSN 8340-01-516-6864, NSN 8340-01-516-6865  
 MAINTENANCE ALLOCATION CHART (MAC)**

**Table 1. MAC for MGPTS.**

(1) GROUP NUMBER	(2) COMPONENT/ASSEMBLY	(3) MAINTENANCE FUNCTION	(4) MAINTENANCE LEVEL					(5) TOOLS AND EQUIPMENT REF CODE	(6) REMARKS CODE
			UNIT		DIRECT SUPPORT	GENERAL SUPPORT	DEPOT		
			C	O	F	H	D		
00	Modular General Purpose Tent System (MGPTS) (Small, Medium, Large)	Inspect	2						A B
		Service	.3						
		Replace		2.2					
01	Tent, Section, End Module Fabric	Inspect	.3				1 (or 2 or 3)	A C, D	
		Repair	.5						
		Replace	.2						
02	Tent, Section, Mid Module Fabric	Inspect	.3				1 (or 2 or 3)	A C, D	
		Repair	.5						
		Replace	.2						
03	Tent Pole (Side)	Inspect	.2				1 (or 2)	A D, E	
		Repair	.5						
		Replace	.4						

Table 1. MAC for MGPTS – continued.

(1) GROUP NUMBER	(2) COMPONENT/ASSEMBLY	(3) MAINTENANCE FUNCTION	(4) MAINTENANCE LEVEL				(5) TOOLS AND EQUIPMENT REF CODE	(6) REMARKS CODE	
			UNIT		DIRECT SUPPORT	GENERAL SUPPORT			DEPOT
			C	O	F	H			D
04	Pole, Tent (End)	Inspect	.2				1 (or 2)	A D, E, F	
		Repair	.5						
		Replace	.4						
05	Pole, Tent (Y)	Inspect	.2				1 (or 2)	A, G	
		Replace		.3					
06	Frame Arch Assembly	Inspect	.2				1 (or 2)	A, H D, E	
		Repair	.5						
		Replace		.3					
07	Stake, Hold Down, Tent	Inspect	.4				1 (or 2)	A	
		Replace		.4					
08	Bags, Tent	Inspect	.6				1 (or 2)	A	
		Replace		.6					
09	Floor	Inspect	.2				1 (or 2)	A	
		Replace		.3					
10	Liner	Inspect	.2				1 (or 2)	A	
		Replace		.3					
11	Plenum	Inspect	.2				1 (or 2)	A	
		Replace		.3					



**Table 2. Tools and Test Equipment for MGPTS.**

TOOL OR TEST EQUIPMENT REF CODE	MAINTENANCE LEVEL	NOMENCLATURE	NATIONAL STOCK NUMBER	TOOL NUMBER
1	0	Repair Kit, Tentage (Green)	8340-01-491-0486	2480268
2	0	Repair Kit, Tentage (Tan)		
3	0	Tentage Repair Kit	8340-00-262-5767	

**Table 3. Remarks for MGPTS.**

REMARKS CODE	REMARKS
A	Inspect in accordance with PMCS.
B	Clean all fabric components with soapy water.
C	Unit level repair is limited to the capabilities of the Tentage Repair Kit.
D	Operator level repair is limited to the capabilities of the Repair Kit, Tentage (Green or Tan).
E	Replace Guy Rope Assembly if frayed or unraveled.
F	Replace Split Ring if broken or elongated.
G	Used only on the Type I system.
H	Used only on the Type II system.

**END OF WORK PACKAGE**



---

**OPERATOR'S AND UNIT MAINTENANCE**  
**MODULAR GENERAL PURPOSE TENT SYSTEM (MGPTS)**  
**NSN 8340-01-456-3633, NSN 8340-01-456-3628, NSN 8340-01-456-3674**  
**NSN 8340-01-516-6860, NSN 8340-01-516-6861, NSN 8340-01-516-6863**  
**NSN 8340-01-491-1507, NSN 8340-01-491-1515, NSN 8340-01-491-1479**  
**NSN 8340-01-516-6859, NSN 8340-01-516-6864, NSN 8340-01-516-6865**  
**REPAIR PARTS AND SPECIAL TOOLS LIST (RPSTL), INTRODUCTION**

---

## INTRODUCTION

### Scope

This RPSTL lists and authorizes spares and repair parts; special tools; special test, measurement, and diagnostic equipment (TMDE); and other special support equipment required for performance of operator or unit maintenance of the Modular General Purpose Tent System (MGPTS). It authorizes the requisitioning, issue, and disposition of spares, repair parts, and special tools as indicated by the source, maintenance, and recoverability (SMR) codes.

### General

In addition to the Introduction work package, this RPSTL is divided into the following work packages.

1. Repair Parts List Work Packages. Work packages containing lists of spares and repair parts authorized by this RPSTL for use in the performance of maintenance. These work packages also include parts which must be removed for replacement of the authorized parts. Parts lists are composed of functional groups in ascending alphanumeric sequence, with the parts in each group listed in ascending figure and item number sequence. Sending units, brackets, filters, and bolts are listed with the component they mount on. Bulk materials are listed by item name in FIG. BULK at the end of the work packages. Repair parts kits are listed separately in their own functional group and work package. Repair parts for reparable special tools are also listed in a separate work package. Items listed are shown on the associated illustrations.

2. Special Tools List Work Packages. Work packages containing lists of special tools, special TMDE, and special support equipment authorized by this RPSTL (as indicated by Basis of Issue (BOI) information in the DESCRIPTION AND USABLE ON CODE (UOC) column). Tools that are components of common tool sets and/or Class VII are not listed.

**INTRODUCTION - continued**

3. Cross-Reference Indexes Work Packages. These are two cross-reference indexes work packages in this RPSTL: the National Stock Number (NSN) Index work package, and the Part Number (P/N) Index work package. The National Stock Number Index work package refers you to the figure and item number. The Part Number Index work package refers you to the figure and item number.

**EXPLANATION OF COLUMNS IN THE REPAIR PARTS LIST AND SPECIAL TOOLS LIST**

ITEM NO. (Column (1)). Indicates the number used to identify items called out in the illustration.

SMR CODE (Column (2)). The SMR code containing supply/requisitioning information, maintenance level authorization criteria, and disposition instruction, as shown in the following breakout:

<u>Source Code</u>	<u>Maintenance Code</u>	<u>Recoverability Code</u>
<u>XX</u>	<u>XX</u>	<u>X</u>
1st two positions: How to get an item.	3rd position: Who can install, replace, or use the item.	4th position: Who can do complete repair* on the item
		5th position: Who determines disposition action on unserviceable items.

---

\* Complete Repair: Maintenance capacity, capability, and authority to perform all corrective maintenance tasks of the "Repair" function in a use/user environment in order to restore serviceability to a failed item.

Source Code. The source code tells you how you get an item needed for maintenance, repair, or overhaul of an end item/equipment. Explanations of source codes follow:

<u>Source Code</u>	<u>Application/Explanation</u>
PA	Stock items; use the applicable NSN to requisition/request items with these source codes. They are authorized to the level indicated by the code entered in the 3rd position of the SMR code.
PB	
PC	
PD	
PE	
PF	
PG	

**EXPLANATION OF COLUMNS IN THE REPAIR PARTS LIST AND SPECIAL TOOLS LIST -  
continued**

**NOTE**

Items coded PC are subject to deterioration.

KD	Items with these codes are not to be requested/requisitioned individually. They are part of a kit which is authorized to the maintenance level indicated in the 3rd position of the SMR code. The complete kit must be requisitioned and applied.
KF	
KB	
MO-Made at unit/ AVUM level	Items with these codes are not to be requisitioned/requested individually. They must be made from bulk material which is identified by the P/N in the DESCRIPTION AND USABLE ON CODE (UOC) column and listed in the bulk material group work package of the RPSTL. If the item is authorized to you by the 3rd position code of the SMR code, but the source code indicates it is made at higher level, order the item from the higher level of maintenance
MF-Made at DS/ AVIM Level	
MH-Made at GS level	
ML-Made at SRA	
MD-Made at depot	
AO-Assembled by Unit/AVUM level	Items with these codes are not to be requested/requisitioned individually. The parts that make up the assembled item must be requisitioned, or fabricated and assembled at the level of maintenance indicated by the source code. If the 3rd position of the SMR code authorizes you to replace the item but the source code indicates the item is assembled at a higher level, order the item from the higher level of maintenance.
AF-Assembled by DS/AVIM level	
AH-Assembled by GS level	
AL-Assembled by SRA	
AD-Assembled by depot	
XA	Do not requisition an "XA" coded item. Order the next higher assembly. (Refer to NOTE below.)
XB	If an item is not available from salvage, order it using the CAGEC and P/N.
XC	Installation drawings, diagrams, instruction sheets, field service drawings; identified by manufacturer's P/N.

**EXPLANATION OF COLUMNS IN THE REPAIR PARTS LIST AND SPECIAL TOOLS LIST -  
continued**

XD                      Item is not stocked. Order an XD-coded item through normal supply channels using the CAGEC and P/N given, If no NSN is available.

**NOTE**

Cannibalization, or controlled exchange, when authorized, may be used as a source of supply for items with the above source codes except for those items source coded "XA" or those aircraft support items restricted by requirements of AR 750-1.

Maintenance Code. Maintenance codes tell you the level(s) of maintenance authorized to use and repair support items. The maintenance codes are entered in the third and fourth positions of the SMR code as follows:

Third Position. The maintenance code entered in the third position tells you the lowest maintenance level authorized to remove, replace, and use an item. The maintenance code entered in the third position will indicate authorization to the following levels of maintenance:

**Maintenance**

**Code**

**Application/Explanation**

- C - Crew or operator maintenance done within unit/AVUM maintenance.
- O - Unit level/AVUM maintenance can remove, replace, and use the item.
- F - Direct support/AVIM maintenance can remove, replace, and use the item.
- H - General support maintenance can remove, replace, and use the item.
- L - Specialized repair activity can remove, replace, and use the item.
- D - Depot can remove, replace, and use the item.

**EXPLANATION OF COLUMNS IN THE REPAIR PARTS LIST AND SPECIAL TOOLS LIST -  
continued**

Fourth Position. The maintenance code entered in the fourth position tells you whether or not the item is to be repaired and identifies the lowest maintenance level with the capability to do complete repair (perform all authorized repair functions).

**NOTE**

Some limited repair may be done on the item at a lower level of maintenance, if authorized by the Maintenance Allocation Chart (MAC) and SMR codes.

**Maintenance**

**Code**

**Application/Explanation**

- O - Unit/AVUM is the lowest level that can do complete repair of the item.
- F - Direct support/AVIM is the lowest level that can do complete repair of the item
- H - General support is the lowest level that can do complete repair of the item.
- L - Specialized repair activity (*enter specialized repair activity designator*) is the lowest level that can do complete repair of the item.
- D - Depot is the lowest level that can do complete repair of the item.
- Z - Nonreparable. No repair is authorized.
- B - No repair is authorized. No parts or special tools are authorized for maintenance of "B" coded items. However, the item may be reconditioned by adjusting, lubricating, etc., at the user level.

**EXPLANATION OF COLUMNS IN THE REPAIR PARTS LIST AND SPECIAL TOOLS LIST -  
continued**

Recoverability Code. Recoverability codes are assigned to items to indicate the disposition action on unserviceable items. The recoverability code is shown in the fifth position of the SMR code as follows:

**Recoverability**

**Code**

**Application/Explanation**

- Z - Nonreparable item. When unserviceable, condemn and dispose of the item at the level of maintenance shown in the third position of the SMR code.
- O - Repairable item. When uneconomically repairable, condemn and dispose of the item at the unit level.
- F - Repairable item. When uneconomically repairable, condemn and dispose of the item at the direct support level.
- H - Repairable item. When uneconomically repairable, condemn and dispose of the item at the general support level.
- D - Repairable item. When beyond lower level repair capability, return to depot. Condemnation and disposal of item are not authorized below depot level.
- L - Repairable item. Condemnation and disposal not authorized below Specialized Repair Activity (SRA).
- A - Item requires special handling or condemnation procedures because of specific reasons (such as precious metal content, high dollar value, critical material, or hazardous material). Refer to appropriate manuals/directives for specific instructions

NSN (Column (3)). The NSN for the item is listed in this column.

CAGEC (Column (4)). The Commercial and Government Entity Code (CAGEC) is a five-digit code which is used to identify the manufacturer, distributor, or Government agency/activity that supplies the item.

PART NUMBER (Column (5)). Indicates the primary number used by the manufacturer (individual, company, firm, corporation, or Government activity), which controls the design and characteristics of the item by means of its engineering drawings, specifications, standards, and inspection requirements to identify an item or range of items.



**EXPLANATION OF COLUMNS IN THE REPAIR PARTS LIST AND SPECIAL TOOLS LIST -  
continued**

**NOTE**

When you use an NSN to requisition an item, the item you receive may have a different P/N from the number listed.

DESCRIPTION AND USABLE ON CODE (UOC) (Column (6)). This column includes the following information:

1. The federal item name, and when required, a minimum description to identify the item.
2. P/Ns of bulk materials are referenced in this column in the line entry to be manufactured or fabricated.
3. Hardness Critical Item (HCI). A support item that provides the equipment with special protection from electromagnetic pulse (EMP) damage during nuclear attack.
4. The statement END OF FIGURE appears just below the last item description in column (6) for a given figure in both the repair parts list and special tools list work packages.

QTY (Column (7)). The QTY (quantity per figure) column indicates the quantity of the item used in the breakout shown on the illustration/figure, which is prepared for a functional group, subfunctional group, or an assembly. A "V" appearing in this column instead of a quantity indicates that the quantity is variable and quantity may change from application to application.

**EXPLANATION OF CROSS-REFERENCE INDEXES WORK PACKAGES FORMAT AND COLUMNS**

1. National Stock Number (NSN) Index Work Package.

STOCK NUMBER Column. This column lists the NSN in National item identification number (NIIN) sequence. The NIIN consists of the last nine digits of the NSN.

NSN  
 (e.g., 5385-01-574-1476)  
 NIIN

When using this column to locate an item, ignore the first four digits of the NSN. However, the complete NSN should be used when ordering items by stock number.

FIG. Column. This column lists the number of the figure where the item is identified/located. The figures are in numerical order in the repair parts list and special tools list work packages.

ITEM Column. The item number identifies the item associated with the figure listed in the adjacent FIG. column. This item is also identified by the NSN listed on the same line.

2. Part Number (P/N) Index Work Package. P/Ns in this index are listed in ascending alphanumeric sequence (vertical arrangement of letter and number combinations which places the first letter or digit of each group in order A through Z, followed by the numbers 0 through 9 and each following letter or digit in like order).

**EXPLANATION OF COLUMNS IN THE REPAIR PARTS LIST AND SPECIAL TOOLS LIST -continued**

PART NUMBER Column. Indicates the P/N assigned to the item.

FIG. Column. This column lists the number of the figure where the item is identified/located in the repair parts list and special tools list work packages.

ITEM Column. The item number is the number assigned to the item as it appears in the figure referenced in the adjacent figure number column."

**SPECIAL INFORMATION**

UOC. The UOC appears in the lower left corner of the Description Column heading. Usable on codes are shown as "UOC: ..." in the Description Column (justified left) on the first line under the applicable item/nomenclature. Uncoded items are applicable to all models. Identification of the UOCs used in the RPSTL are:

<b>Code</b>	<b>Used On</b>	<b>Code</b>	<b>Used On</b>
FQJ	MGPTS, Type I, Small, Green	FQK	MGPTS, Type I, Medium, Green
FQL	MGPTS, Type I, Large, Green	FSC	MGPTS, Type I, Small, Tan
FSD	MGPTS, Type I, Medium, Tan	FSE	MGPTS, Type I, Large, Tan
FTJ	MGPTS, Type II, Small, Green	FTK	MGPTS, Type II, Medium, Green
FTL	MGPTS, Type II, Large, Green	FTM	MGPTS, Type II, Small, Tan
FTN	MGPTS, Type II, Medium, Tan	FTP	MGPTS, Type II, Large, Tan

Fabrication Instructions. Bulk materials required to manufacture items are listed in the bulk material functional group of this RPSTL. Part numbers for bulk material are also referenced in the Description Column of the line item entry for the item to be manufactured/fabricated. Detailed fabrication instructions for items source coded to be manufactured or fabricated are found in *TM 10-8340-240-12&P*.

Index Numbers. Items which have the word BULK in the figure column will have an index number shown in the item number column. This index number is a cross-reference between the NSN / P/N index work packages and the bulk material list in the repair parts list work package.

**HOW TO LOCATE REPAIR PARTS**

1. When NSNs or P/Ns Are Not Known.

First. Using the table of contents, determine the assembly group to which the item belongs. This is necessary since figures are prepared for assembly groups and subassembly groups, and lists are divided into the same groups.

Second. Find the figure covering the functional group or the subfunctional group to which the item belongs.

Third. Identify the item on the figure and note the number(s).

**HOW TO LOCATE REPAIR PARTS - continued**

Fourth. Look in the repair parts list work packages for the figure and item numbers. The NSNs and part numbers are on the same line as the associated item numbers.

**2. When NSN Is Known.**

First. If you have the NSN, look in the STOCK NUMBER column of the NSN index work package. The NSN is arranged in NIIN sequence. Note the figure and item number next to the NSN.

Second. Turn to the figure and locate the item number. Verify that the item is the one you are looking for.

**3. When P/N Is Known.**

First. If you have the P/N and not the NSN, look in the PART NUMBER column of the P/N index work package. Identify the figure and item number.

Second. Look up the item on the figure in the applicable repair parts list work package.





**OPERATOR'S AND UNIT MAINTENANCE**  
**GROUP 00 MODULAR GENERAL PURPOSE TENT SYSTEM (MGPTS)**  
**(SMALL, MEDIUM, LARGE)**  
NSN 8340-01-456-3633, NSN 8340-01-456-3628, NSN 8340-01-456-3674  
NSN 8340-01-516-6860, NSN 8340-01-516-6861, NSN 8340-01-516-6863  
NSN 8340-01-491-1507, NSN 8340-01-491-1515, NSN 8340-01-491-1479  
NSN 8340-01-516-6859, NSN 8340-01-516-6864, NSN 8340-01-516-6865  
**REPAIR PARTS AND SPECIAL TOOLS LIST (RPSTL)**

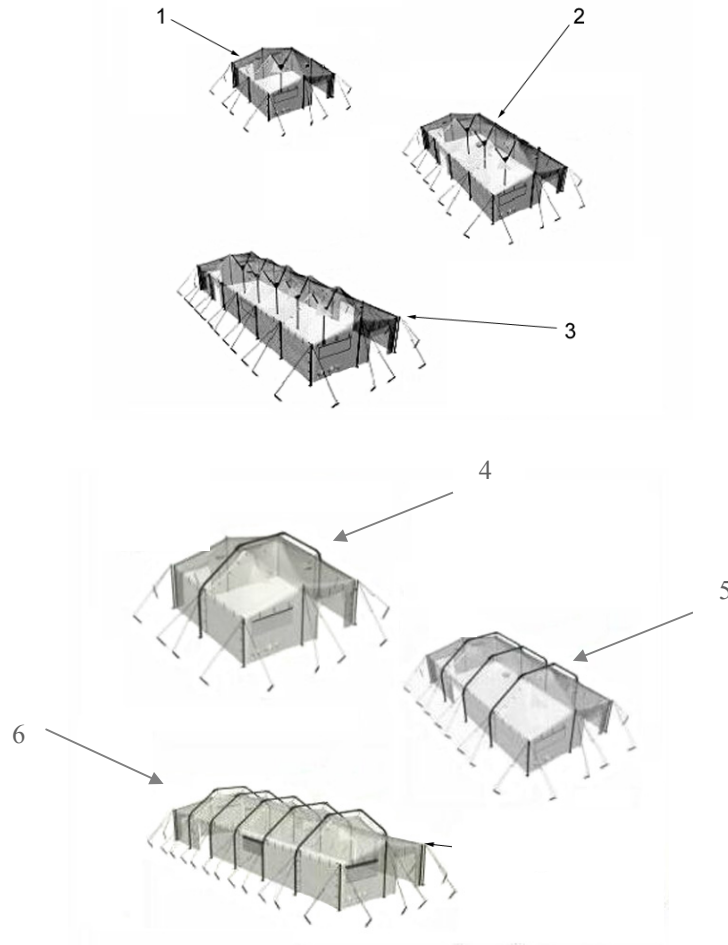

**Figure 1. MGPTS Small, Medium, Large.**

(1) ITEM NO.	(2) SMR CODE	(3) NSN	(4) CAGEC	(5) PART NUMBER	(6) DESCRIPTION AND USABLE ON CODE (UOC)	(7) QTY
GROUP 00 MGPTS						
FIG 1. MGPTS Small, Medium, Large.						
1	PDOOO	8340-01-456-3633	73005	2480107	MGPTS, Small, Green UOC: FQJ	1
		8340-01-491-1507	73005	2480277	MGPTS, Small, Tan UOC: FSC	1
2	PDOOO	8340-01-456-3628	73005	2480108	MGPTS, Medium, Green UOC: FQK	1
		8340-01-491-1515	73005	2480148	MGPTS, Medium, Tan UOC: FSD	1
3	PDOOO	8340-01-456-3674	73005	2480109	MGPTS, Large, Green UOC: FQL	1
		8340-01-491-1479	73005	2480278	MGPTS, Large, Tan UOC: FSE	1
4	PDOOO	8340-01-516-6860	73005	2480135	MGPTS, Small, Green UOC: FTJ	1
	PDOOO	8340-01-516-6859	73005	2480204	MGPTS, Small, Tan UOC: FTM	1
5	PDOOO	8340-01-516-6861	73005	2480136	MGPTS, Medium, Green UOC: FTK	1
	PDOOO	8340-01-516-6864	73005	2480205	MGPTS, Medium, Tan UOC: FTN	1
6	PDOOO	8340-01-516-6863	73005	7248013	MGPTS, Large, Green UOC: FTL	1
	PDOOO	8340-01-516-6865	73005	2480206	MGPTS, Large, Tan UOC: FTP	1
<b>END OF FIGURE</b>						







---

**OPERATOR'S AND UNIT MAINTENANCE  
MODULAR GENERAL PURPOSE TENT SYSTEM (MGPTS)  
GROUP 01 TENT SECTION, END MODULE FABRIC  
NSN 8340-01-477-9569, NSN 8340-01-491-1465  
NSN 8340-01-522-3517, NSN 8340-01-523-0774  
REPAIR PARTS AND SPECIAL TOOLS LIST (RPSTL)**

---

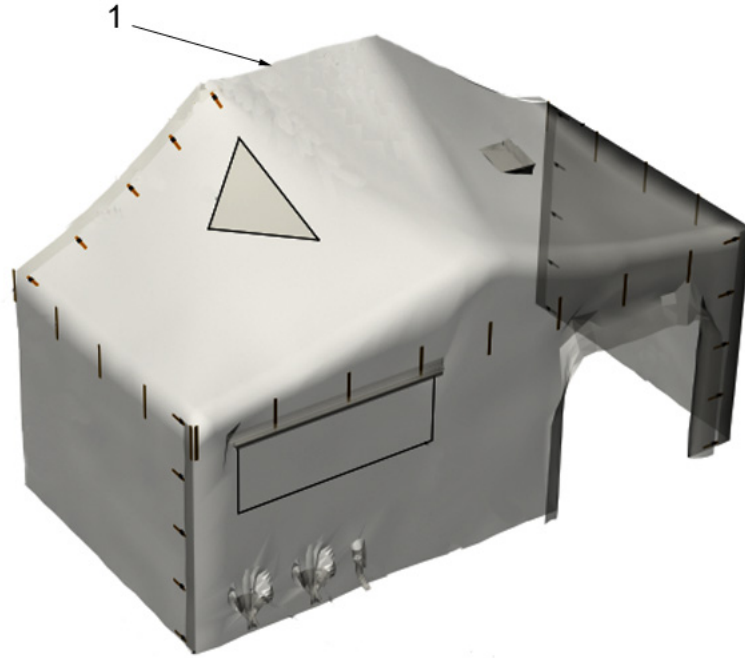

**Figure 2. End Module Fabric Tent Section.**

(1) ITEM NO.	(2) SMR CODE	(3) NSN	(4) CAGEC	(5) PART NUMBER	(6) DESCRIPTION AND USABLE ON CODE (UOC)	(7) QTY
					GROUP 01 Tent Section, End Module Fabric	
					FIG. 2 End Module Fabric Tent Section.	
1	PACOO	8340-01-477-9569	73005	2480100	Tent Section, End Module Fabric Green UOC: FQJ	2
	PACOO	8340-01-491-1465	73005	2480149	Tent Section, End Module Fabric Tan	2
	PACOO	8340-01-522-3517	73005	2480139	Tent Section, End Module Fabric Green UOC: FTJ, FTK, FTL	2
	PACOO	8340-01-523-0774	73005	2480196	Tent Section, End Module Fabric Tan UOC: FTM, FTN, FTP	2
					<b>END OF FIGURE</b>	





---

**OPERATOR'S AND UNIT MAINTENANCE  
MODULAR GENERAL PURPOSE TENT SYSTEM (MGPTS)  
GROUP 02 TENT SECTION, MID MODULE FABRIC TYPE I AND II  
NSN 8340-01-477-9567, NSN 8340-01-491-1463  
NSN 8340-01-523-0084, NSN 8340-01-523-0768  
REPAIR PARTS AND SPECIAL TOOLS LIST (RPSTL)**

---

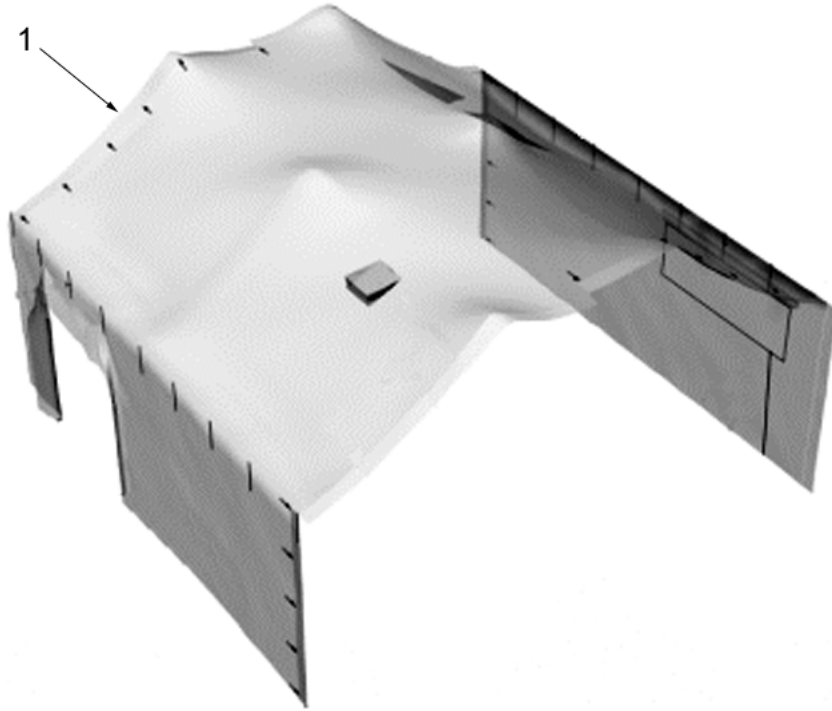

**Figure 3. Mid Module Fabric Tent Section.**

(1) ITEM NO.	(2) SMR CODE	(3) NSN	(4) CAGEC	(5) PART NUMBER	(6) DESCRIPTION AND USABLE ON CODE (UOC)	(7) QTY
					GROUP 02 Tent Section, Mid Module Fabric	
					FIG. 3 Mid Module Fabric Tent Section.	
1	PACOO	8340-01-477-9567	73005	2480102	Tent Section, Mid Module Fabric Green UOC: FQK UOC: FQL	1 2
	PACOO	8340-01-491-1463	73005	2480210	Tent Section, Mid Module Fabric Tan UOC: FSD UOC: FSE	1 2
	PACOO	8340-01-523-0084	73005	2480140	Tent Section, Mid Module Fabric Green UOC: FTK UOC: FTL	1 2
	PACOO	8340-01-523-0768	73005	2480197	Tent Section, Mid Module Fabric Tan UOC: FTN UOC: FTP	1 2
<b>END OF FIGURE</b>						







---

**OPERATOR'S AND UNIT MAINTENANCE  
MODULAR GENERAL PURPOSE TENT SYSTEM (MGPTS)  
GROUP 03 TENT POLE (SIDE)  
NSN 8340-01-477-9566  
REPAIR PARTS AND SPECIAL TOOLS LIST (RPSTL)**

---

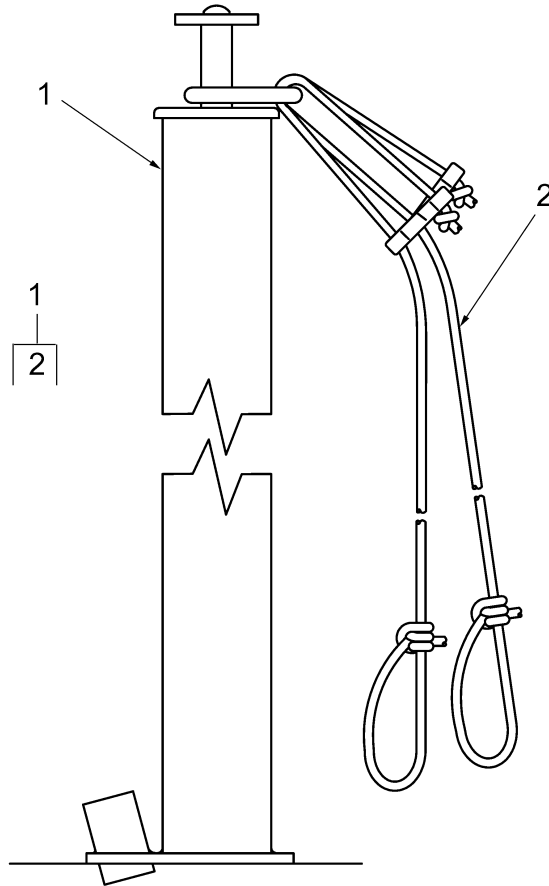

**Figure 4. Tent Pole (Side).**

(1) ITEM NO.	(2) SMR CODE	(3) NSN	(4) CAGEC	(5) PART NUMBER	(6) DESCRIPTION AND USABLE ON CODE (UOC)	(7) QTY
					GROUP 03 TENT POLE (SIDE)	
					FIG. 4 Tent Pole (Side)	
1	PACOO	8340-01-477-9566	73005	2470824	Pole, Tent (Side) UOC: FQJ, FSC UOC: FQK, FSD UOC: FQL, FSE UOC: FTJ, FTM UOC: FTK, FTN UOC: FTL, FTP	4
2	PACZZ	4020-01-477-9670	73005	2480251	. Fiber Rope Assy	2
<b>END OF FIGURE</b>						





**OPERATOR'S AND UNIT MAINTENANCE  
MODULAR GENERAL PURPOSE TENT SYSTEM (MGPTS)  
GROUP 04 POLE, TENT (END)  
NSN 8340-01-477-9525  
REPAIR PARTS AND SPECIAL TOOLS LIST (RPSTL)**

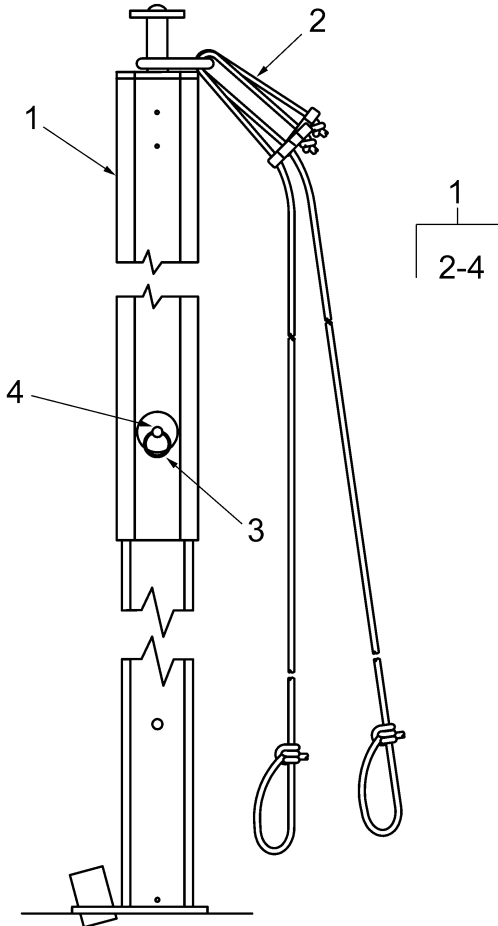

**Figure 5. Tent Pole (End).**

(1) ITEM NO.	(2) SMR CODE	(3) NSN	(4) CAGEC	(5) PART NUMBER	(6) DESCRIPTION AND USABLE ON CODE (UOC)	(7) QTY
					GROUP 04 Pole, Tent (End)	
					FIG. 5 Tent Pole (End)	
1	PACOO	8340-01-477-9525	73005	2470823	Pole, Tent (End)	2
2	PACZZ	4020-01-477-9670	73005	2480251	. Fiber Rope Assy	2
3	PACZZ	5325-01-477-9531	73005	2480253	. Ring, Retaining	2
4	PACZZ	5315-01-477-9244	73005	2480254	. Pin, Straight, Headed	2
<b>END OF FIGURE</b>						







---

**OPERATOR'S AND UNIT MAINTENANCE  
MODULAR GENERAL PURPOSE TENT SYSTEM (MGPTS)  
GROUP 05 POLE, TENT (Y)  
NSN 8340-01-477-9570  
REPAIR PARTS AND SPECIAL TOOLS LIST (RPSTL)**

---

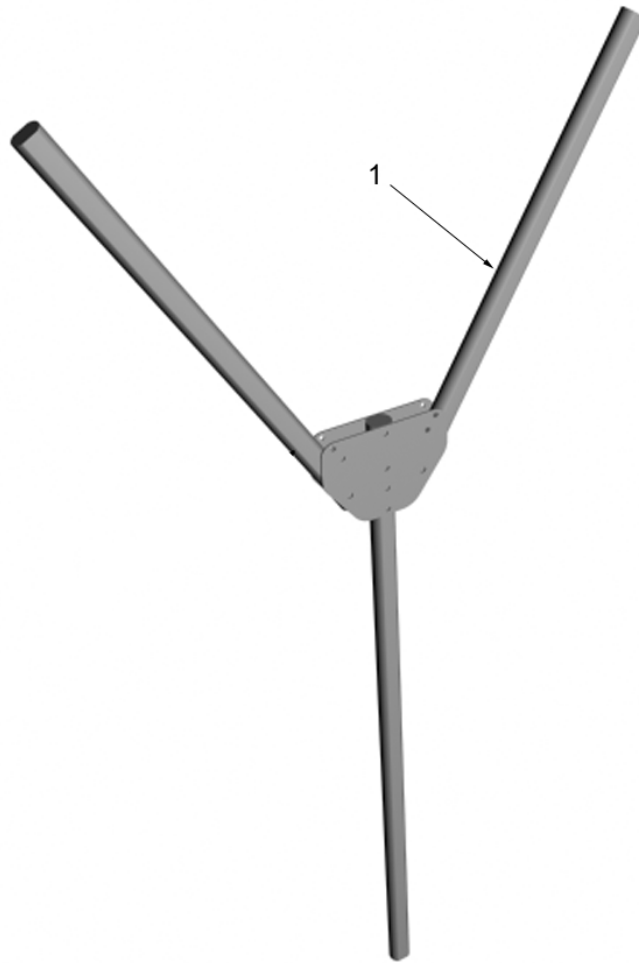

**Figure 6. Tent Pole (Y).**

(1) ITEM NO.	(2) SMR CODE	(3) NSN	(4) CAGEC	(5) PART NUMBER	(6) DESCRIPTION AND USABLE ON CODE (UOC)	(7) QTY
					GROUP 05 Pole, Tent (Y)	
					FIG. 6 Tent Pole (Y)	
1	PACZZ	8340-01-477-9570	73005	2470822	Pole, Tent (Y)	
					UOC: FQJ, FSC	1
					UOC: FQK, FSD	3
					UOC: FQL, FSE	5
					<b>END OF FIGURE</b>	





---

**OPERATOR'S AND UNIT MAINTENANCE  
MODULAR GENERAL PURPOSE TENT SYSTEM (MGPTS)  
GROUP 06 ARCH, TENT FRAME  
NSN 8340-01-523-0802  
REPAIR PARTS AND SPECIAL TOOLS LIST (RPSTL)**

---

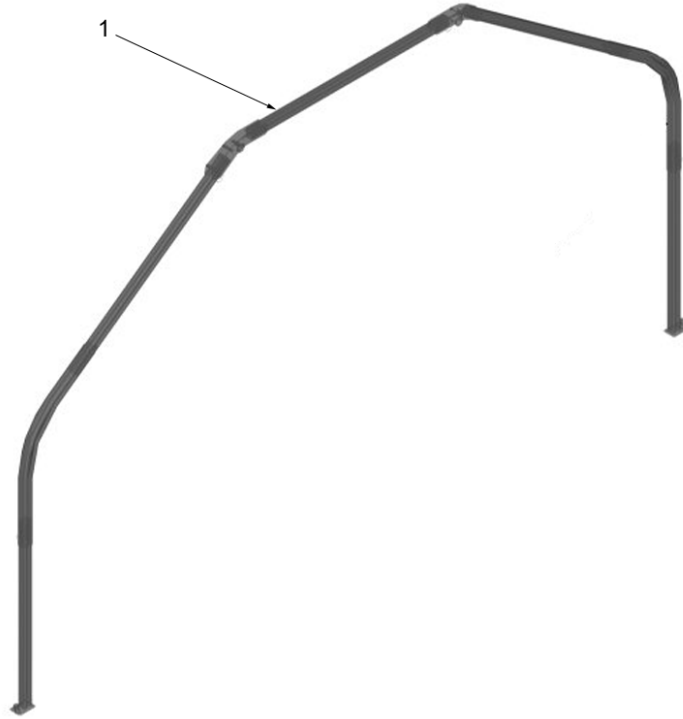

**Figure 7. Tent Frame Arch.**

(1) ITEM NO.	(2) SMR CODE	(3) NSN	(4) CAGEC	(5) PART NUMBER	(6) DESCRIPTION AND USABLE ON CODE (UOC)	(7) QTY
					GROUP 06 Arch, Tent Frame	
					FIG. 7 Tent Frame Arch.	
1	PACZZ	8340-01-523-0802	73005	2480264	Frame Section, Tent, Arch	
					UOC: FTJ, FTM	1
					UOC: FTK, FTN	3
					UOC: FTL, FTP	5
<b>END OF FIGURE</b>						







---

**OPERATOR'S AND UNIT MAINTENANCE  
MODULAR GENERAL PURPOSE TENT SYSTEM (MGPTS)  
GROUP 07 STAKE, HOLD DOWN, TENT  
NSN 8340-01-478-0133, NSN 8340-01-478-0136  
REPAIR PARTS AND SPECIAL TOOLS LIST (RPSTL)**

---

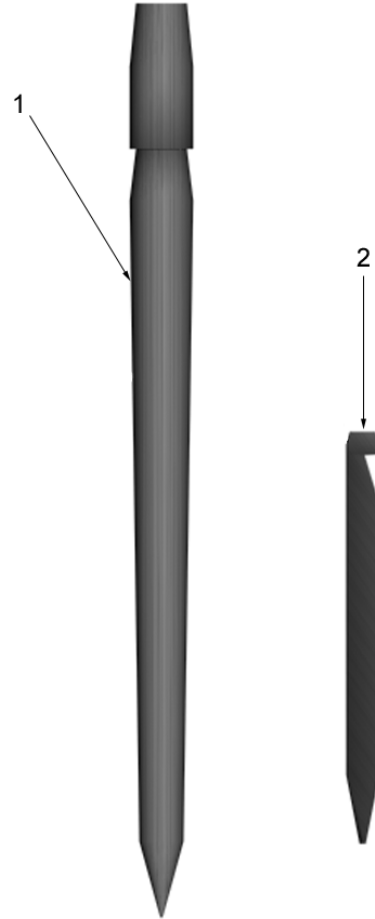

**Figure 8. Tent Stake.**

(1) ITEM NO.	(2) SMR CODE	(3) NSN	(4) CAGEC	(5) PART NUMBER	(6) DESCRIPTION AND USABLE ON CODE (UOC)	(7) QTY
					GROUP 07 STAKE, HOLD DOWN, TENT	
					FIG. 8 Tent Stake.	
1	PACZZ	8340-01-478-0133	73005	5440664	Stake, Hold Down, Tent	
					UOC: FQJ, FSC	16
					UOC: FTJ, FTM	16
					UOC: FQK, FSD	24
					UOC: FTK, FTN	24
					UOC: FQL, FSE	32
					UOC: FTL, FTP	32
2	PACZZ	8340-01-478-0136	73005	5685537	Stake, Hold Down, Tent	
					UOC: FQJ, FSC	24
					UOC: FTJ, FTM	24
					UOC: FQK, FSD	36
					UOC: FTK, FTN	36
					UOC: FQL, FSE	48
					UOC: FTL, FTP	48
					<b>END OF FIGURE</b>	





**OPERATOR'S AND UNIT MAINTENANCE  
MODULAR GENERAL PURPOSE TENT SYSTEM (MGPTS)  
GROUP 08 BAGS, TENT  
NSN 8340-01-477-9561, NSN 8340-01-477-9564, NSN 8340-01-477-9563  
NSN 8340-01-477-9562, NSN 8340-01-523-0817, NSN 8340-01-523-0818  
REPAIR PARTS AND SPECIAL TOOLS LIST (RPSTL)**

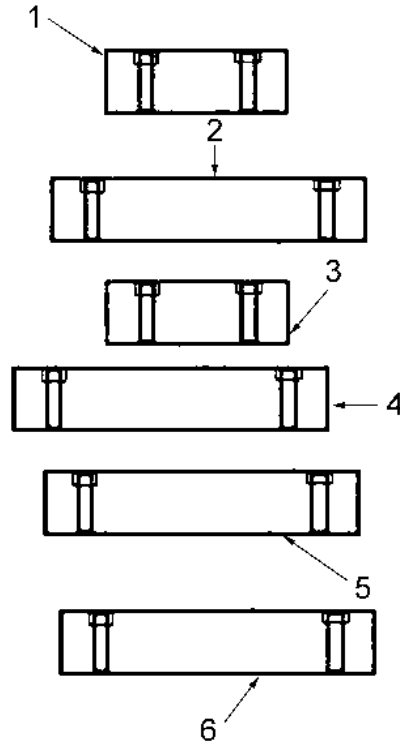

**Figure 9. Bags, Tent, Type I & Type II.**

(1) ITEM NO.	(2) SMR CODE	(3) NSN	(4) CAGEC	(5) PART NUMBER	(6) DESCRIPTION AND USABLE ON CODE (UOC)	(7) QTY
					GROUP 08 BAGS, TENT	
					FIG. 9 Bags, Tent, Type I & Type II	
1	PACZZ	8340-01-477-9561	73005	2480103	BAG, TENT, END	2
2	PACZZ	8340-01-477-9564	73005	2480110	BAG, TYPE I, END UOC: FQJ, FSC UOC: FQK, FSD UOC: FQL, FSE	1 1 1
3	PACZZ	8340-01-477-9563	73005	2480111	BAG, TENT, MID UOC: FQK, FSD, FTR, FTN UOC: FQL, FSE, FTL, FTP	1 2
4	PACZZ	8340-01-477-9562	73005	2480114	BAG, TYPE I, MID UOC: FQK, FSD UOC: FQL, FSE	1 2
5	PACZZ	8340-01-523-0817	73005	2480242	BAGS, TYPE II, END UOC: FTJ, FTM UOC: FTK, FTN UOC: FTL, FTP	1 1 1
6	PACZZ	8340-01-523-0818	73005	2480241	BAGS, TYPE II, MID UOC: FTK, FTN UOC: FTL, FTP	1 2
<b>END OF FIGURE</b>						







---

**OPERATOR'S AND UNIT MAINTENANCE  
MODULAR GENERAL PURPOSE TENT SYSTEM (MGPTS)  
GROUP 09 FLOOR, TENT  
NSN 8340-01-477-1397, NSN 8340-01-477-1449  
REPAIR PARTS AND SPECIAL TOOLS LIST (RPSTL)**

---

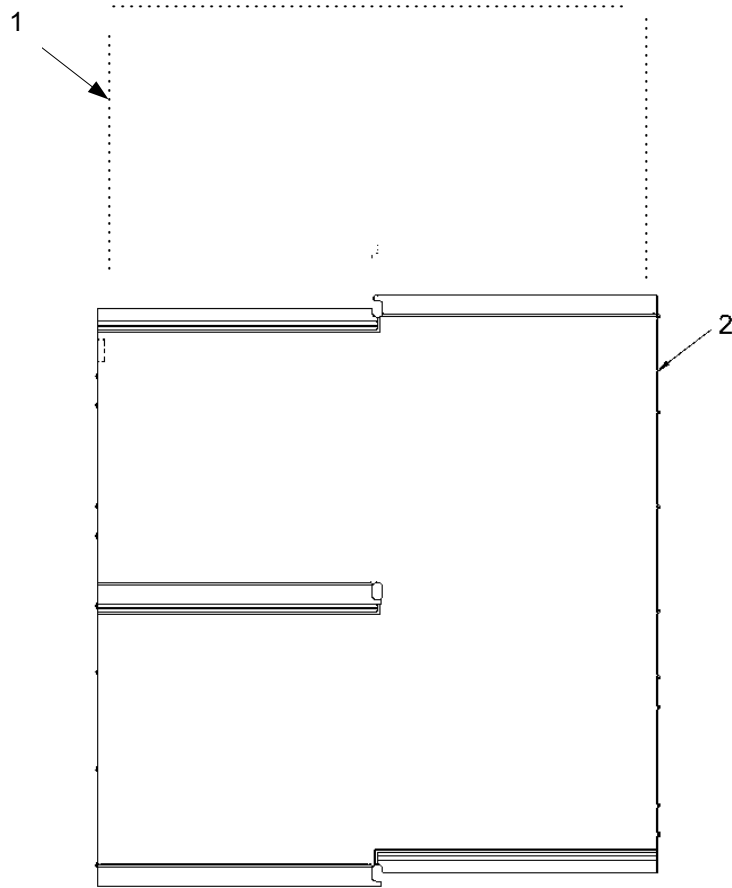

**Figure 10. Tent Floor for the Type I & Type II.**

(1) ITEM NO.	(2) SMR CODE	(3) NSN	(4) CAGEC	(5) PART NUMBER	(6) DESCRIPTION AND USABLE ON CODE (UOC)	(7) QTY
					GROUP 09 Floor, Tent	
					FIG. 10 Tent Floor for the Type I & Type II.	
1	PACZZ	8340-01-477-1397	73005	2480127	Floor, Tent, End Section	2
2	PACZZ	8340-01-491-1449	73005	2480128	Floor, Tent, Mid Section	
					UOC: FQK, FSD	1
					UOC: FTK, FTN	1
					UOC: FQL, FSE	2
					UOC: FTL, FTP	2
					<b>END OF FIGURE</b>	





**OPERATOR'S AND UNIT MAINTENANCE  
MODULAR GENERAL PURPOSE TENT SYSTEM (MGPTS)  
GROUP 10 LINER  
NSN 8340-01-491-1392, NSN 8340-01-477-1390  
REPAIR PARTS AND SPECIAL TOOLS LIST (RPSTL)**

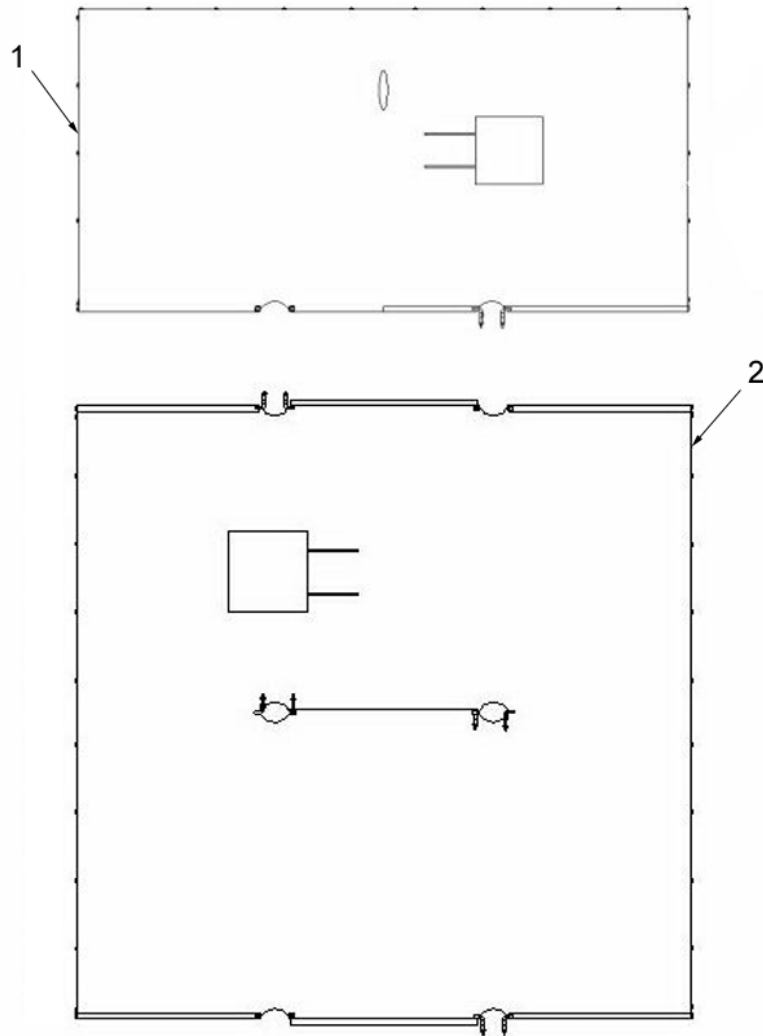

Figure 11. Type I & Type II Liner.

(1) ITEM NO.	(2) SMR CODE	(3) NSN	(4) CAGEC	(5) PART NUMBER	(6) DESCRIPTION AND USABLE ON CODE (UOC)	(7) QTY
GROUP 10 LINER						
FIG. 11 Type I & Type II Liner.						
1	PACZZ	8340-01-491-1392	73005	2480125	Liner, End Section	2
2	PACZZ	8340-01-477-1390	73005	2480126	Liner, End Section	
					UOC: FQK, FSD	1
					UOC: FTK, FTN	1
					UOC: FQL, FSE	2
					UOC: FTL, FTP	2
<b>END OF FIGURE</b>						







**OPERATOR'S AND UNIT MAINTENANCE  
MODULAR GENERAL PURPOSE TENT SYSTEM (MGPTS)  
GROUP 11 PLENUM  
NSN 8340-01-523-0826, NSN 8340-01-523-0828  
REPAIR PARTS AND SPECIAL TOOLS LIST (RPSTL)**

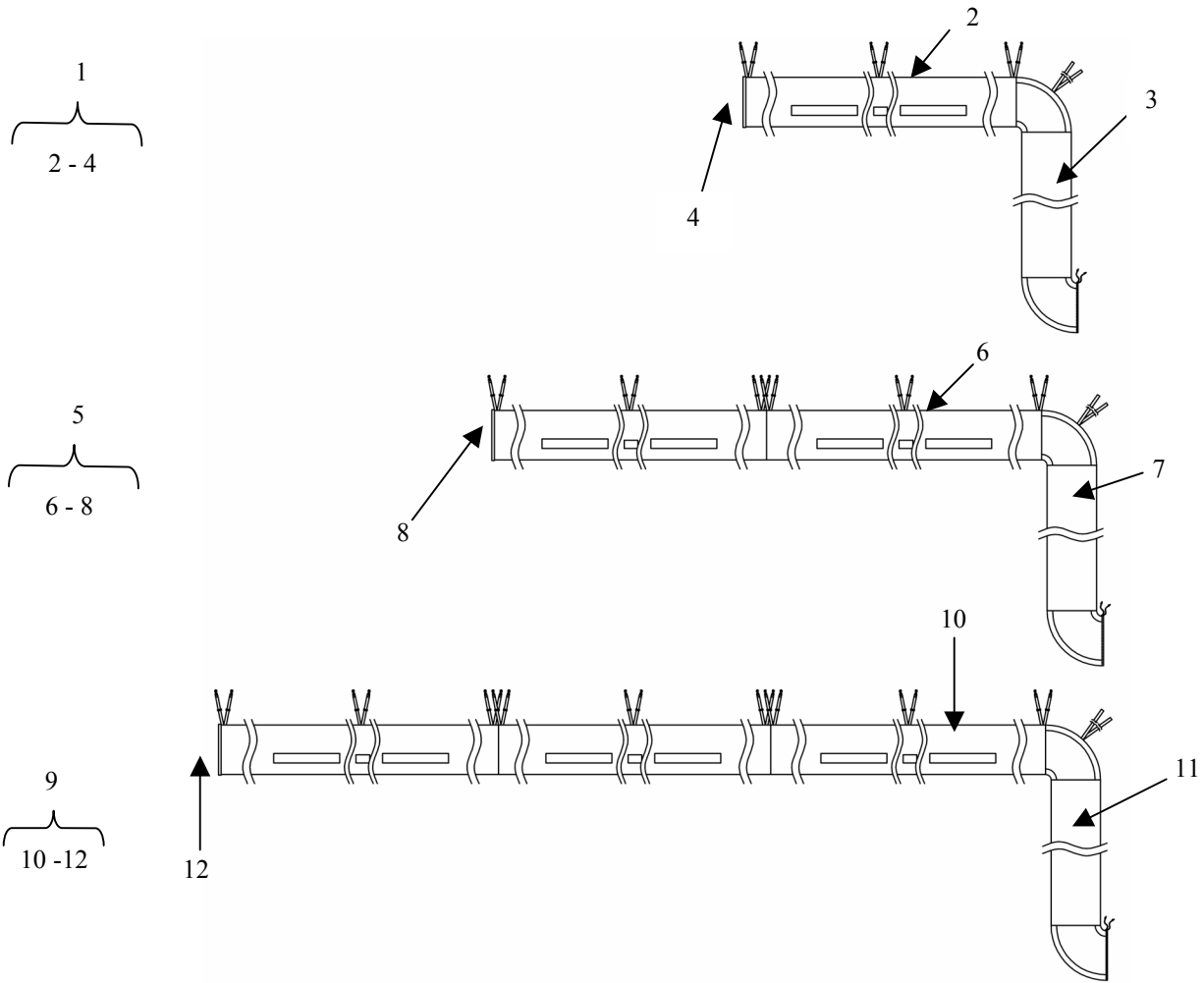

**Figure 12. Plenum for the Type I & Type II.**

(1) ITEM NO.	(2) SMR CODE	(3) NSN	(4) CAGEC	(5) PART NUMBER	(6) DESCRIPTION AND USABLE ON CODE (UOC)	(7) QTY
					GROUP 11 Plenum	
					FIG. 12 Plenum for the Type I & Type II.	
1	PACOO	8340-01-523-0826	81337	5-4-8688-1	Plenum, Tent Assembly (Small) UOC: FSC, FTJ, FQJ, FTM	1
2	PACOO		81337	5-4-8690-1	. Plenum, Horizontal Assembly UOC: FSC, FTJ, FQJ, FTM	1
3	PACOO		81337	5-4-8689-1	. Plenum, Inlet Assembly UOC: FSC, FTJ, FQJ, FTM	1
4	PACOO		81337	5-4-8691-1	. Plenum, End Cap Assembly UOC: FSC, FTJ, FQJ, FTM	1
5	PACOO	8340-01-523-0828	81337	5-4-8688-2	Plenum, Tent Assembly (Medium) UOC: FQK, FSD, FTK, FTN	1
6	PACOO		81337	5-4-8690-1	. Plenum, Horizontal Assembly UOC: FQK, FSD, FTK, FTN	2
7	PACOO		81337	5-4-8689-1	. Plenum, Inlet Assembly UOC: FQK, FSD, FTK, FTN	1
8	PACOO		81337	5-4-8691-1	. Plenum, End Cap Assembly UOC: FQK FSD, FTK, FTN	1
9	PACOO		81337	5-4-8688-3	Plenum Assembly (Large) UOC: FQL, FSC, FTL, FTP	1
10	PACOO		81337	5-4-8690-1	. Plenum, Horizontal Assembly UOC: FQL, FSE, FTL, FTP	3
11	PACOO		81337	5-4-8689-1	. Plenum, Inlet Assembly UOC: FQL, FSE, FTL, FTP	1
12	PACOO		81337	5-4-8691-1	. Plenum, End Cap Assembly UOC: FQL, FSE, FTL, FTP	1
<b>END OF FIGURE</b>						





---

**OPERATOR'S AND UNIT MAINTENANCE  
MODULAR GENERAL PURPOSE TENT SYSTEM (MGPTS)  
GROUP 12 REPAIR KIT  
NSN 8340-01-491-0486  
REPAIR PARTS AND SPECIAL TOOLS LIST (RPSTL)**

---

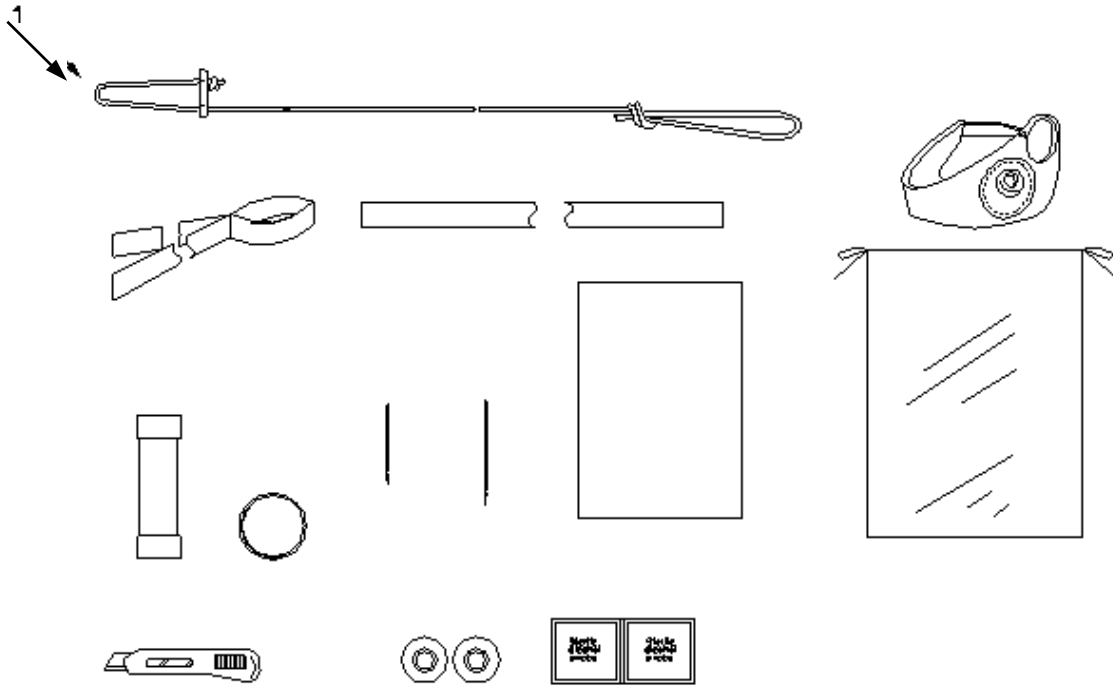

Figure 13. Repair Kit.

(1) ITEM NO.	(2) SMR CODE	(3) NSN	(4) CAGEC	(5) PART NUMBER	(6) DESCRIPTION AND USABLE ON CODE (UOC)	(7) QTY
					Group 12 REPAIR KIT	
					FIG. 13 Repair Kit.	
1	PAOZZ	8340-01-491-0486	73005	2480147	Repair Kit, Tentage (Green)	
					UOC: FQJ, FTJ	1
					UOC: FQK, FTK	1
					UOC: FQL, FTL	1
	PAOZZ		73005	2480268	Repair Kit, Tentage (Tan)	
					UOC: FSC, FTM	1
					UOC: FSD, FTN	1
					UOC: FSE, FTP	1
					<b>END OF FIGURE</b>	





**OPERATOR'S AND UNIT MAINTENANCE  
 MODULAR GENERAL PURPOSE TENT SYSTEM (MGPTS)  
 NSN 8340-01-456-3633, NSN 8340-01-456-3628, NSN 8340-01-456-3674  
 NSN 8340-01-516-6860, NSN 8340-01-516-6861, NSN 8340-01-516-6863  
 NSN 8340-01-491-1507, NSN 8340-01-491-1515, NSN 8340-01-491-1479  
 NSN 8340-01-516-6859, NSN 8340-01-516-6864, NSN 8340-01-516-6865  
 BULK MATERIAL  
 REPAIR PARTS AND SPECIAL TOOLS LIST (RPSTL)**

(1) ITEM NO.	(2) SMR CODE	(3) NSN	(4) CAGEC	(5) PART NUMBER	(6) DESCRIPTION AND USABLE ON CODE (UOC)	(7) QTY
					GROUP 99 BULK MATERIAL	
1	PAOZZ		45849	5001-B	Buckle, Female, 1 in.	AR
2	PAOZZ		45849	5001-B	Buckle, Male, 1 in.	AR
3	PAOZZ	8340-00-205-2759	82399		Slip Tent Line	AR
4	PAOZZ		57771	671/264	Grommet, Oval, TY VCL3, SI#1, MIL-G- 16491F	AR
5	PAOZZ		57771	#4 RRG/SW Black	Grommet /Spur, Washer, Rolled, RIM, #4	AR
6	PAOZZ		34918	8217	Vinyl/Green/White Webbing UOC: FQJ, FQK, FQL, FTJ, FTK, FTL	AR
7	PAOZZ		34918	S8217	Vinyl/Tan/White Webbing UOC: FSC, FSD, FSE, FTM, FTN, FTP	AR
					<b>END OF FIGURE</b>	



**OPERATOR'S AND UNIT MAINTENANCE  
MODULAR GENERAL PURPOSE TENT SYSTEM (MGPTS)  
NSN 8340-01-456-3633, NSN 8340-01-456-3628, NSN 8340-01-456-3674  
NSN 8340-01-516-6860, NSN 8340-01-516-6861, NSN 8340-01-516-6863  
NSN 8340-01-491-1507, NSN 8340-01-491-1515, NSN 8340-01-491-1479  
NSN 8340-01-516-6859, NSN 8340-01-516-6864, NSN 8340-01-516-6865  
NATIONAL STOCK NUMBER INDEX**

<b>STOCK NUMBER</b>	<b>FIG.</b>	<b>ITEM</b>	<b>STOCK NUMBER</b>	<b>FIG.</b>	<b>ITEM</b>
8340-00-205-2759	14	3	8340-01-516-6859	1	4
8340-01-456-3633	1	1	8340-01-516-6860	1	4
8340-01-456-3628	1	2	8340-01-516-6861	1	5
8340-01-456-3674	1	3	8340-01-516-6863	1	6
8340-01-477-1390	11	2	8340-01-516-6864	1	5
8340-01-477-1397	10	1	8340-01-516-6865	1	6
5315-01-477-9244	5	4	8340-01-523-0802	7	1
5365-01-477-9531	5	3	8340-01-523-0084	2	1
8340-01-477-9525	5	1	8340-01-523-0768	2	1
8340-01-477-9561	9	1	8340-01-523-0774	2	1
8340-01-477-9562	9	4	8340-01-523-0817	9	5
8340-01-477-9563	9	3	8340-01-523-0818	9	6
8340-01-477-9564	9	2	8340-01-523-0826	12	1
8340-01-477-9566	4	1	8340-01-523-0828	12	5
8340-01-477-9567	3	1	8340-01-523-3517	2	1
8340-01-477-9569	2	1			
8340-01-477-9570	6	1			
4020-01-477-9670	4	2			
8340-01-478-0133	8	1			
8340-01-478-0136	8	2			
8340-01-491-1392	11	1			
8340-01-491-1449	10	2			
8340-01-491-1463	3	1			
8340-01-491-1465	2	1			
8340-01-491-1479	1	3			
8340-01-491-1507	1	1			
8340-01-491-1515	1	2			



**OPERATOR'S AND UNIT MAINTENANCE  
MODULAR GENERAL PURPOSE TENT SYSTEM (MGPTS)  
NSN 8340-01-456-3633, NSN 8340-01-456-3628, NSN 8340-01-456-3674  
NSN 8340-01-516-6860, NSN 8340-01-516-6861, NSN 8340-01-516-6863  
NSN 8340-01-491-1507, NSN 8340-01-491-1515, NSN 8340-01-491-1479  
NSN 8340-01-516-6859, NSN 8340-01-516-6864, NSN 8340-01-516-6865  
PART NUMBER INDEX**

<b>PART NUMBER</b>	<b>FIG.</b>	<b>ITEM</b>	<b>PART NUMBER</b>	<b>FIG.</b>	<b>ITEM</b>
2470822	6	1	2480242	9	5
2470823	5	1	2480233	12	2
2470824	4	1	2480234	11	1
2480100	2	1	2480235	11	3
2480102	3	1	2480251	4	2
2480103	9	1	2480253	5	3
2480107	1	1	2480254	5	4
2480108	1	2	2480264	7	1
2480109	1	3	2480268	13	1
2480110	9	2	2480277	1	1
2480111	9	3	2480278	1	3
2480114	9	4	4RRG/SW	14	2
2480125	11	1	5-4-8688-1	12	1
2480126	11	2	5-4-8688-2	12	5
2480127	10	1	5-4-8688-3	12	9
2480128	10	2	5-4-8689-1	12	3
2480135	1	4		12	8
2480136	1	5		12	11
2480137	1	6	5-4-8690-1	12	2
2480139	2	1		12	6
2480140	3	1		12	10
2480147	13	1	5-4-8691-1	12	4
2480148	1	2		12	12
2480149	2	1	5000-B	14	1
2480196	2	1	5001-B	14	8
2480197	3	1	5440664	8	1
2480204	1	4	5685537	8	2
2480205	1	5	618-000-6024	14	6
2480206	1	6	671/264	14	3
2480210	3	1	8217	14	4
2480241	9	6	S8217	14	7



---

**OPERATOR'S AND UNIT MAINTENANCE**  
**MODULAR GENERAL PURPOSE TENT SYSTEM (MGPTS)**  
NSN 8340-01-456-3633, NSN 8340-01-456-3628, NSN 8340-01-456-3674  
NSN 8340-01-516-6860, NSN 8340-01-516-6861, NSN 8340-01-516-6863  
NSN 8340-01-491-1507, NSN 8340-01-491-1515, NSN 8340-01-491-1479  
NSN 8340-01-516-6859, NSN 8340-01-516-6864, NSN 8340-01-516-6865  
**COMPONENTS OF END ITEM (COEI) AND BASIC ISSUE ITEMS (BII) LISTS**

---

## **COMPONENTS OF END ITEM (COEI) AND BASIC ISSUE ITEMS (BII) LISTS**

### **INTRODUCTION**

#### **Scope**

This work package lists COEI and BII for the MGPTS to help you inventory items for safe and efficient operation of the equipment.

#### **General**

The COEI and BII Lists are divided into the following lists:

**Components of End Item (COEI).** This listing is for informational purposes only and is not authority to requisition replacements. These items are part of the MGPTS. As part of the end item, these items must be with the end item whenever it is issued or transferred between property accounts. Items of COEI are removed and separately packaged for transportation or shipment only when necessary. Illustrations are furnished to help you find and identifying the items.

**Basic Issue Items (BII).** These essential items are required to place the MGPTS in operation, operate it, and to do emergency repairs. Although shipped separately packaged, BII must be with the MGPTS during operation and when it is transferred between property accounts. Listing these items is your authority to request/requisition them for replacement based on authorization of the end item by the TOE/MTOE. Illustrations are furnished to help you find and identify the items.

**INTRODUCTION - continued**

**Explanation of Columns in the COEI List and BII List**

Column (1) - Illus Number. Gives you the number of the item illustrated.

Column (2) - National Stock Number (NSN). Indicates the stock number of the item to be used for requisitioning purposes.

Column (3) - Description, CAGEC, and Part Number. Identifies the Federal item name (in all capital letters) followed by a minimum description when needed. The stowage location of COEI and BII is also included in this column. The last line below the description is the CAGEC (commercial and Government entity code) (in parentheses) and the part number.

Column (4) - Usable On Code. When applicable, gives you a code if the item you need is not the same for different models of equipment. These codes are identified below:

<u>Code</u>	<u>Used on</u>
FQJ.....	MGPTS, Type I, Small, Green
FSC.....	MGPTS, Type I, Small, Tan
FTJ.....	MGPTS, Type II, Small, Green
FTM.....	MGPTS, Type II, Small, Tan
FQK.....	MGPTS, Type I, Medium, Green
FSD.....	MGPTS, Type I, Medium, Tan
FTK.....	MGPTS, Type II, Medium, Green
FTN.....	MGPTS, Type II, Medium, Tan
FQL.....	MGPTS, Type I, Large, Green
FSE.....	MGPTS, Type I, Large, Tan
FTL.....	MGPTS, Type II, Large, Green
FTP.....	MGPTS, Type II, Large, Tan

Column (5) - Unit of Measure (U/M). Indicates the physical measurement or count of the item as issued per the National Stock Number shown in column (2).

Column (6) - Qty Rqr. Indicates the quantity required.



COMPONENTS OF END ITEM (COEI)

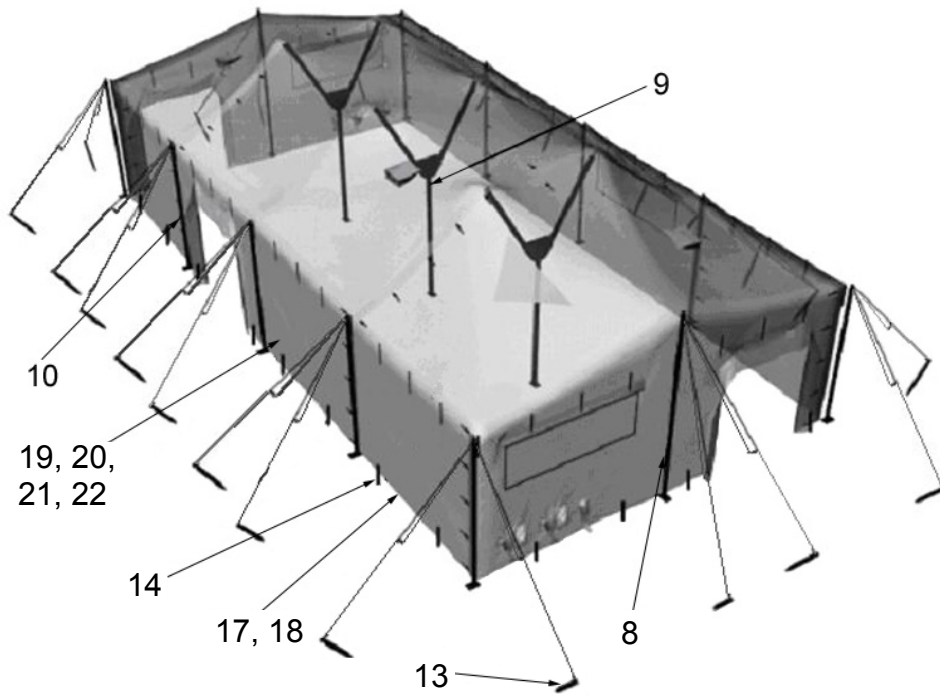
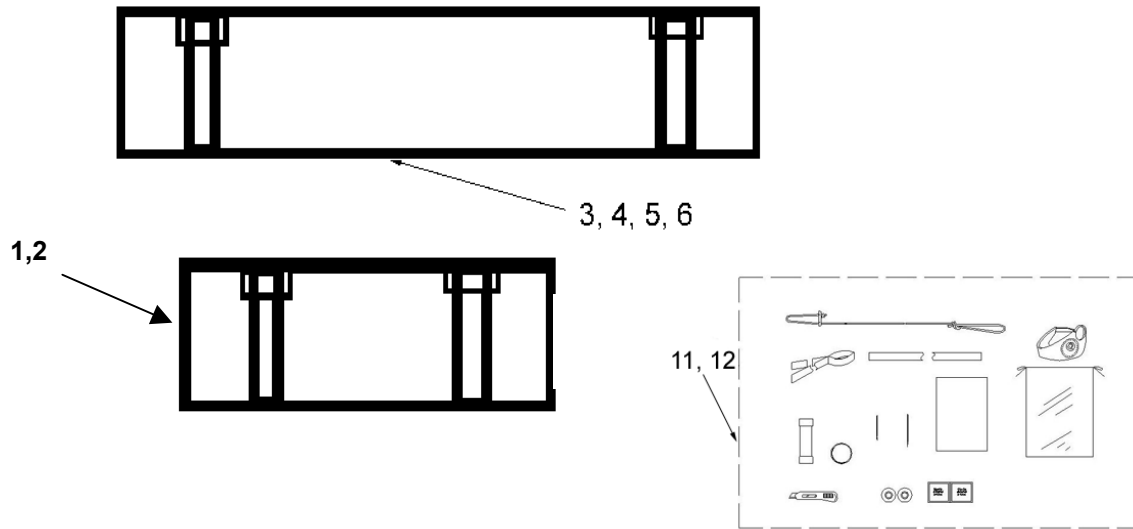

COMPONENTS OF END ITEM (COEI) – continued

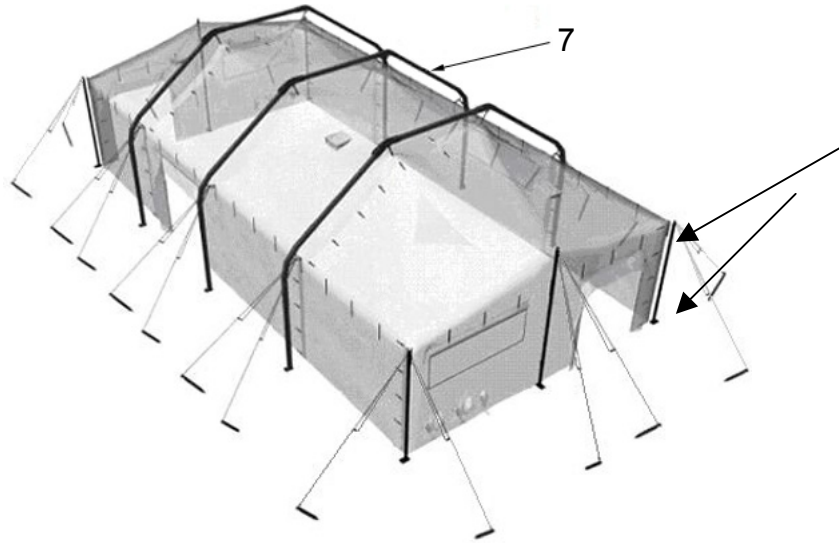

COMPONENTS OF END ITEM (COEI) - continued

Table 1. Components of End Item List.

(1) ILLUS NUMBER	(2) NATIONAL STOCK NUMBER	(3) DESCRIPTION, CAGEC, AND PART NUMBER	(4) USABLE ON CODE	(5) U/M	(6) QTY RQR
1	8340-01-477-9561	BAGS, TENT, END (73005) 2480103		EA	2
2	8340-01-477-9563	BAGS, TENT, MID (73005) 2480111	FQJ, FSC, FTJ, FTM, FTR, FTN, FQK, FSD, FTL, FQL, FSE, FTP	EA EA EA	0 1 2
3	8340-01-477-9564	BAGS, TYPE I, END (73005) 2480110	FQJ, FSC FQK, FSD FQL, FSE	EA	1
4	8340-01-477-9562	BAGS, TYPE I, MID (73005) 2480114	FQJ, FSC FQK, FSD FQL, FSE	EA EA EA	0 1 2
5	8340-01-523-0817	BAGS, TYPE II, END (73005) 2480242	FTJ, FTK, FTL, FTM, FTN, FTP	EA	2
6	8340-01-523-0818	BAGS, TYPE II, MID (73005) 2480241	FTJ, FTM FTK, FTN FTL, FTP	EA EA EA	0 1 2
7	8340-01-523-0802	FRAME SECTION, TENT, ARCH (73005) 2480264	FTJ, FTM FTK, FTN FTL, FTP	EA EA EA	1 3 5
8	8340-01-477-9525	POLE, TENT, END (73005) 2470823		EA	2

Table 1. Components of End Item List – continued.

(1) ILLUS NUMBER	(2) NATIONAL STOCK NUMBER	(3) DESCRIPTION, CAGEC, AND PART NUMBER	(4) USABLE ON CODE	(5) U/M	(6) QTY RQR
9	8340-01-477-9570	POLE ASSY, TENT Y, (73005) 2470822	FQJ, FSC FQK, FSD FQL, FSE	EA EA EA	1 3 5
10	8340-01-477-9566	POLE TENT, SIDE (73005) 2470824	FQJ, FSC FTJ, FTM FQK, FSD FTK, FTN FQL, FSE FTL, FTP	EA EA EA EA EA EA	6 4 10 4 14 4
11	8340-01-491-0486	REPAIR KIT, TENTAGE (GREEN) (73005) 2480147	FQJ, FTJ FQK, FTK FQL, FTL	EA	1
12		REPAIR KIT, TENTAGE (TAN) (73005) 2480268	FSC, FSD FSE, FTM FTN, FTP	EA	1
13	8340-01-478-0133	STAKES, HOLD DOWN, TENT (73005) 5440664	FQJ, FSC FTJ, FTM FQK, FSD FTK, FTN FQL, FSE FTL, FTP	EA EA EA EA EA EA	16 16 24 24 32 32
14	8340-01-478-0136	STAKES, PLASTIC (73005) 5685537	FQJ, FSC FTJ, FTM FQK, FSD FTK, FTN FQL, FSE FTL, FTP	EA EA EA EA EA EA	24 24 36 36 48 48
15	8340-01-477-9569	TENT, SECTION, END MODULE FABRIC, TYPE I GREEN, (73005) 2480100	FQJ, FQK, FQL	EA	2
16	8340-01-491-1465	TENT, SECTION, END MODULE FABRIC, TYPE I TAN, (73005) 2480149	FSC, FSD, FSE	EA	2
17	8340-01-522-3517	TENT, SECTION, END MODULE FABRIC, TYPE II GREEN, (73005) 2480139	FTJ, FTK, FTL	EA	2

Table 1. Components of End Item List – continued.

(1) ILLUS NUMBER	(2) NATIONAL STOCK NUMBER	(3) DESCRIPTION, CAGEC, AND PART NUMBER	(4) USABLE ON CODE	(5) U/M	(6) QTY RQR
18	8340-01-523-0774	TENT, SECTION, END MODULE FABRIC, TYPE II TAN, (73005) 2480196	FTM, FTN, FTP	EA	2
19	8340-01-477-9567	TENT, SECTION, MID MODULE FABRIC, TYPE I GREEN, (73005) 2480102	FQJ FQK FQL	EA EA EA	0 1 2
20	8340-01-491-1463	TENT, SECTION, MID MODULE FABRIC, TYPE I TAN (73005) 2480210	FSC FSD FSE	EA EA EA	0 1 2
21	8340-01-523-0084	TENT, SECTION, MID MODULE FABRIC, TYPE II GREEN, (73005) 2480140	FTJ FTK FTL	EA EA EA	0 1 2
22	8340-01-523-0768	TENT, SECTION, MID MODULE FABRIC, TYPE II TAN, (73005) 2480197	FTM FTN FTP	EA EA EA	0 1 2

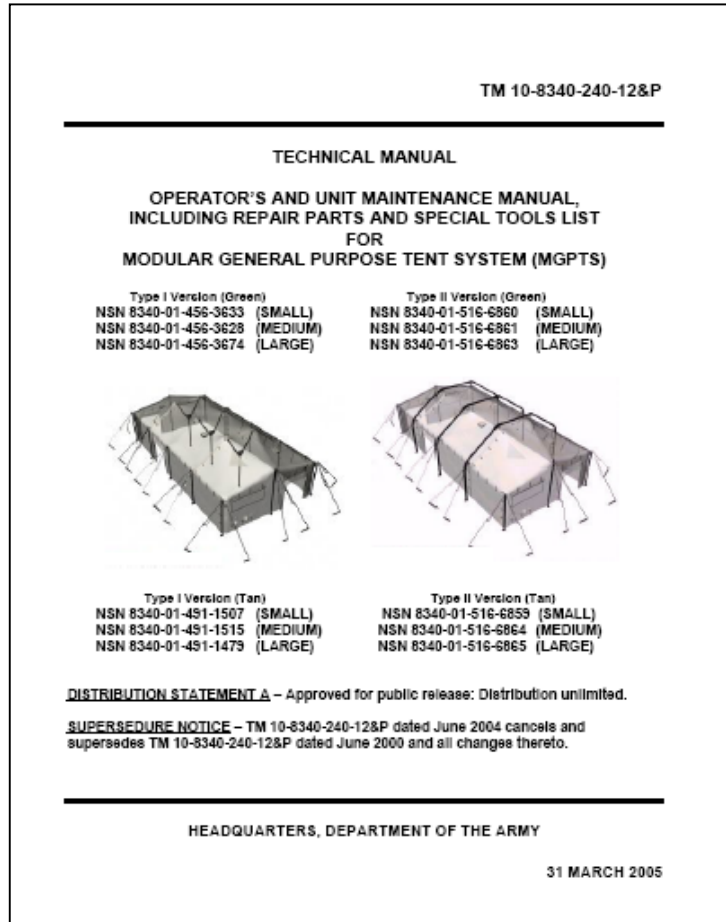

Table 2. Basic Issue Items List.

(1) ILLUS NUMBER	(2) NATIONAL STOCK NUMBER	(3) DESCRIPTION, CAGEC, AND PART NUMBER	(4) USABLE ON CODE	(5) U/M	(6) QTY RQR
1	N/A	TM 10-8340-240-12&P		EA	1

END OF WORK PACKAGE

**OPERATOR'S AND UNIT MAINTENANCE  
 MODULAR GENERAL PURPOSE TENT SYSTEM (MGPTS)  
 NSN 8340-01-456-3633, NSN 8340-01-456-3628, NSN 8340-01-456-3674  
 NSN 8340-01-516-6860, NSN 8340-01-516-6861, NSN 8340-01-516-6863  
 NSN 8340-01-491-1507, NSN 8340-01-491-1515, NSN 8340-01-491-1479  
 NSN 8340-01-516-6859, NSN 8340-01-516-6864, NSN 8340-01-516-6865  
 ADDITIONAL AUTHORIZATION LIST (AAL)**

**ADDITIONAL AUTHORIZATION LIST (AAL)**

**INTRODUCTION**

**Scope**

This work package lists additional items you are authorized for the support of the MGPTS.

**General**

This list identifies items that do not have to accompany the MGPTS and that do not have to be turned in with it. These items are authorized to you by CTA, MTOE, TDA, or JTA.

**Explanation of Columns in the AAL**

Column (1) - National Stock Number (NSN). Identifies the stock number of the item to be used for requisitioning purposes.

Column (2) - Description, Commercial and Government Entity Code (CAGEC), and Part Number (P/N). Identifies the Federal item name (in all capital letters) followed by a minimum description when needed. The last line below the description is the CAGEC (in parentheses) and the part number.

Column (3) - Usable On Code. When applicable, gives you a code if the item you need is not the same for different models of equipment. These codes are identified below:

<u>Code</u>	<u>Used On</u>	<u>Code</u>	<u>Used On</u>
FQJ	MGPTS, Type I, Small, Green	FQK	MGPTS, Type I, Medium, Green
FQL	MGPTS, Type I, Large, Green	FSC	MGPTS, Type I, Small, Tan
FSD	MGPTS, Type I, Medium, Tan	FSE	MGPTS, Type I, Large, Tan
FTJ	MGPTS, Type II, Small, Green	FTK	MGPTS, Type II, Medium, Green
FTL	MGPTS, Type II, Large, Green	FTM	MGPTS, Type II, Small, Tan
FTN	MGPTS, Type II, Medium, Tan	FTP	MGPTS, Type II, Large, Tan

**INTRODUCTION - continued**

Column (4) - Unit of Measure (U/M). Indicates the physical measurement or count of the item as issued per the National Stock Number shown in column (1).

Column (5) - Qty Recm. Indicates the quantity recommended.

**ADDITIONAL AUTHORIZED LIST ITEMS**

**Table 1. Additional Authorization List.**

(1) NATIONAL STOCK NUMBER	(2) DESCRIPTION, CAGEC, AND PART NUMBER	(3) USABLE ON CODE	(4) U/M	(5) QTY RECM
8340-00-951-6423	Ground Anchor Kit (81337)		EA	1
6230-01-242-2016	Light Set, Portable, Fluorescent, Type I, (81337)		EA	2
5120-00-926-7116	Mallet, Wood (81337)		EA	1
8340-00-823-7451	Pin, Tent, Metal, Type II (12" Long) (81337) 5-4-791	FQJ, FSC FTJ, FTM FQK, FSD FTK, FTN FQL, FSE FTL, FTP	EA	24 24 36 36 48 48
8340-00-261-9751	Pin, Tent, Wood, Size 2 (24" Long) (81337)	FQJ, FSC FTJ, FTM FQK, FSD FTK, FTN FQL, FSE FTL, FTP	EA	16 16 24 24 32 32
4520-01-329-3451	Radiant Type Portable 45K Btu/hr (H-45)	FQJ, FSC FTJ, FTM FQK, FSD FTK, FTN FQL, FSE FTL, FTP	EA	2 2 4 4 6 6
5120-01-464-6340	Rake, Snow (62840) SNORK-618		EA	1



ADDITIONAL AUTHORIZED LIST ITEMS-continued

Table 1. Additional Authorization List – continued.

(1) NATIONAL STOCK NUMBER	(2) DESCRIPTION, CAGEC, AND PART NUMBER	(3) USABLE ON CODE	(4) U/M	(5) QTY RECM
4240-01-315-1864 4240-01-315-1863	Respirator, Air Filtering (55799) 808072		GL	1
8340-01-478-0133	Stake, Wood (73005) 5440664	FQJ, FSC FTJ, FTM FQK, FSD FTK, FTN FQL, FSE FTL, FTP	EA	16 16 24 24 32 32
8340-00-262-5767	Tentage Repair Kit (81337) 8340-90-CL-POL		EA	1
8340-01-186-3010	Vestibule, Frame Assy. (81337) 5-4-3343	FQJ, FSC FTJ, FTM FQK, FSD FTK, FTN FQL, FSE FTL, FTP	EA	6 6 9 9 12 12
8340-01-186-3026	Vestibule, Green (81337) 5-4-3370-1	FQJ, FTJ FQK, FTK FQL, FTL	EA	2 3 4
8340-01-198-7621	Vestibule, Tan (81337) 5-4-3370-2	FSC, FTM FSD, FTN FSE, FTP	EA	2 3 4

END OF WORK PACKAGE



---

**OPERATOR'S AND UNIT MAINTENANCE**  
**MODULAR GENERAL PURPOSE TENT SYSTEM (MGPTS)**  
**NSN 8340-01-456-3633, NSN 8340-01-456-3628, NSN 8340-01-456-3674**  
**NSN 8340-01-516-6860, NSN 8340-01-516-6861, NSN 8340-01-516-6863**  
**NSN 8340-01-491-1507, NSN 8340-01-491-1515, NSN 8340-01-491-1479**  
**NSN 8340-01-516-6859, NSN 8340-01-516-6864, NSN 8340-01-516-6865**  
**EXPENDABLE AND DURABLE ITEMS LIST**

---

## EXPENDABLE AND DURABLE ITEMS LIST

### INTRODUCTION

#### Scope

This work package lists expendable and durable items that you will need to operate and maintain the MGPTS. This list is for information only and is not authority to requisition the listed items. These items are authorized to you by CTA 50-970, Expendable/Durable Items (Except Medical, Class V Repair Parts, and Heraldic Items), or CTA 8-100, Army Medical Department Expendable/Durable Items.

#### Explanation of Columns in the Expendable/Durable Items List

Column (1) - Item Number. This number is assigned to the entry in the list and is referenced in the narrative instructions to identify the item (e.g., Use brake fluid (item 5, WP 0098 00)).

Column (2) - Level. This column identifies the lowest level of maintenance that requires the listed item (C = Operator/Crew, O = Unit/AVUM).

Column (3) - National Stock Number (NSN). This is the NSN assigned to the item which you can use to requisition it.

Column (4) - Item Name, Description, Commercial and Government Entity Code (CAGEC), and Part Number (P/N). This column provides the other information you need to identify the item.

Column (5) - Unit of Measure (U/M). This code shows the physical measurement or count of an item, such as gallon, dozen, gross, etc.

EXPENDABLE AND DURABLE ITEMS LIST

Table 1. Expendable and Durable Items List.

(1) ITEM NUMBER	(2) LEVEL	(3) NATIONAL STOCK NUMBER	(4) ITEM NAME, DESCRIPTION, CAGEC, PART NUMBER	(5) U/M
1	C	7920-00-240-7174	Brush, Scrub, w/out Handle (80244)	EA
2	C	4240-01-204-2827	Filter Cartridge (55799) 464023	EA
3	C	6515-01-461-8939 6515-01-461-8933 6515-01-461-8929	Gloves, Latex-Nitrile (01MX7) 47746-956 small (01MX7) 47746-954 med (01MX7) 47746-952 large	PR
4	C	4240-01-063-5996	Goggles, Chemical Splash (02622) 484BAF	EA
5	C	8520-00-129-0803	Soap, Toilet, Hand, Cake	BX
6	C	7920-00-205-1711	Wiping Rags	BL

END OF WORK PACKAGE

ALPHABETICAL INDEX

<u>Subject</u>	<u>WP Sequence No.</u>
<b>A</b>	
Additional Authorized List.....	0040 00-2
<b>B</b>	
Basic Issue Items List (BII).....	0039 00-8
Bulk Items.....	0036 00-1
<b>C</b>	
Components of End Item (COEI).....	0039 00-1
Corrosion Prevention and Control.....	0001 00-2
<b>D</b>	
Destruction of Army Materiel to Prevent Enemy Use.....	0001 00-2
Differences Between Models.....	0002 00-8
Doors - Operate (for Type I).....	0004 00-23
Doors - Operate (for Type II).....	0005 00-26
<b>E</b>	
EIR.....	0001 00-1
End Module, Fabric - Inspection.....	0011 00-1
Equipment, Characteristics, Capabilities and Features.....	0002 00-1
Equipment Data.....	0002 00-9
Expendable and Durable List.....	0041 00-2
<b>F</b>	
Fabric Assembly End Module – Repair and Replace.....	0013 00-1
Fabric Assembly Mid Module – Repair and Replace.....	0013 00-1
Floor - Installing (for Type I).....	0006 00-1
Floor - Removing (for Type I).....	0006 00-5
Floor - Installing (for Type II).....	0006 00-3
Floor - Removing (for Type II).....	0006 00-5
<b>H</b>	
How to Locate Repair Parts.....	0022 00-8
How to Use this Manual.....	iii
<b>L</b>	
Light Assemblies - Install (for Type I).....	0004 00-17
Light Assemblies - Remove (for Type I).....	0004 00-26
Light Assemblies - Install (for Type II).....	0005 00-21
Light Assemblies - Remove (for Type II).....	0005 00-32
Liner - Installing (for Type I).....	0007 00-1
Liner - Removing (for Type I).....	0007 00-4
Liner - Installing (for Type II).....	0007 00-6
Liner - Removing (for Type II).....	0007 00-9
List of Abbreviations/Acronyms.....	0001 00-3
List of Effective Pages.....	A
Location and Description of Major Components.....	0002 00-1
<b>M</b>	
Maintenance Allocation Chart, (MAC).....	0021 00-1
Maintenance Allocation Chart (MAC), Introduction.....	0020 00-1

ALPHABETICAL INDEX - continued

<u>Subject</u>	<u>WP Sequence No.</u>
<b>M - continued</b>	
Maintenance Forms and Records .....	0001 00-1
Mid Module, Fabric Inspection .....	0011 00-1
Modular General Purpose Tent System (MGPTS)	
<b>N</b>	
National Stock Number Index .....	0037 00-1
Nomenclature Cross-Reference List.....	0001 00-3
<b>O</b>	
Operation Under Usual Conditions – Floor .....	0006 00-1
Operation Under Usual Conditions – Liner .....	0007 00-1
Operation Under Usual Conditions - Plenum.....	0008 00-1
Operation Under Unusual Conditions .....	0009 00-1
<b>P</b>	
Part Number Index .....	0038 00-1
Preventative Maintenance Checks and Services (PMCS).....	0012 00-1
Plenum - Install .....	0008 00-1
Plenum - Remove .....	0008 00-5
Pole Assemblies Inspection .....	0011 00-1
Preventive Maintenance Checks and Services (PMCS), Introduction.....	0011 00-1
<b>R</b>	
References.....	0019 00-1
Repair Parts and Special Tools List (RPSTL).....	0022 00-1
Reporting Equipment Improvement Recommendations (EIR).....	0001 00-1
Ropes, Guy Inspection .....	0011 00-1
RPSTL - Bags, Tent.....	0031 00-2
RPSTL –Arch, Tent Frame.....	0029 00-2
RPSTL – Floor, Tent .....	0032 00-2
RPSTL – Liner.....	0033 00-2
RPSTL – Plenum .....	0034 00-2
RPSTL – Section Assembly, End Module Fabric .....	0024 00-2
RPSTL – Section Assembly, Mid Module Fabric .....	0025 00-2
RPSTL – Tent Pole (End) .....	0027 00-2
RPSTL – Tent Pole (Side).....	0026 00-2
RPSTL - Tent Pole Y.....	0028 00-2
<b>S</b>	
Setup Type I System.....	0004 00-1
Setup Type I System.....	0005 00-7
Sitting Requirements (for Type I) .....	0004 00-1
Sitting Requirements (for Type II) .....	0005 00-1
Stovepipe Operate Openings (for Type I) .....	0004 00-24
Stovepipe Operate Openings (for Type II) .....	0005 00-27
Stakes Inspection .....	0011 00-1
<b>T</b>	
Theory of Operation .....	0003 00-1
Type I - Setup .....	0004 00-1

ALPHABETICAL INDEX - continued

<u>Subject</u>	<u>WP Sequence No.</u>
<b>T- continued</b>	
Type I - Site Selection .....	0004 00-1
Type I - Layout fabric sections .....	0004 00-1
Type I - Connect fabric sections .....	0004 00-3
Type I - Setting up tent poles .....	0004 00-6
Type I - Raising .....	0004 00-12
Type I - Tensioning .....	0004 00-14
Type I - Striking .....	0004 00-27
Type I - Fold Fabric sections .....	0004 00-30
Type II - Site Selection .....	0005 00-1
Type II - Layout fabric sections .....	0005 00-1
Type II - Connect fabric sections .....	0005 00-3
Type II - Raising .....	0005 00-12
Type II - Tensioning .....	0005 00-16
Type II - Striking .....	0005 00-29
Type II - Fold Fabric sections .....	0005 00-32
<b>V</b>	
Vestibule - Install (for Type I) .....	0004 00-18
Vestibule - Remove (for Type I) .....	0004 00-25
Vestibule - Install (for Type II) .....	0005 00-22
Vestibule - Remove (for Type II) .....	0005 00-28
Vents - Roof (for Type I) .....	0004 00-24
Vents - Roof (for Type II) .....	0005 00-27
<b>W</b>	
Walls - Operate fabric (for Type I) .....	0004 00-24
Walls - Operate fabric (for Type II) .....	0005 00-27
Warning Summary .....	a
Windows - Operate (for Type I) .....	0004 00-23
Windows - Operate (for Type II) .....	0005 00-26





By Order of the Secretary of the Army:

PETER J. SCHOOMAKER  
General, United States Army  
*Chief of Staff*

Official:

  
SANDRA R. RILEY  
*Administrative Assistant to the  
Secretary of the Army*  
0514006

**Distribution:** To be distributed in accordance with initial distribution number (IDN) 256618 requirements for TM 10-8340-240-12&P.



## ***These are the instructions for sending an electronic 2028***

The following format must be used if submitting an electronic 2028. The subject line must be exactly the same and all fields must be included; however only the following fields are mandatory: 1, 3, 4, 5, 6, 7, 8, 9, 10, 13, 15, 16, 17, and 27.

From: "Whomever" <whomever@avma27.army.mil>  
To: amssbriml@natick.army.mil

Subject: DA Form 2028

1. From: Joe Smith
2. Unit: home
3. Address: 4300 Park
4. City: Hometown
5. St: MO
6. Zip: 77777
7. Date Sent: 19-OCT-93
8. Pub no: 55-2840-229-23
9. Pub Title: TM
10. Publication Date: 04-JUL-85
11. Change Number: 7
12. Submitter Rank: MSG
13. Submitter FName: Joe
14. Submitter MName: T
15. Submitter LName: Smith
16. Submitter Phone: 123-123-1234
17. Problem: 1
18. Page: 2
19. Paragraph: 3
20. Line: 4
21. NSN: 5
22. Reference: 6
23. Figure: 7
24. Table: 8
25. Item: 9
26. Total: 123
27. Text:

This is the text for the problem below line 27.



<b>RECOMMENDED CHANGES TO PUBLICATIONS AND BLANK FORMS</b> For use of this form, see AR 25-30; the proponent agency is ODISC4.						Use Part II (reverse) for Repair Parts and Special Tool Lists (RPSTL) and Supply Catalogs/Supply Manuals (SC/SM).	<b>DATE</b> 21 October 2003
<b>TO:</b> (Forward to proponent of publication or form) (Include ZIP Code) COMMANDER U.S. ARMY TANK-AUTOMOTIVE AND ARMAMENT COMMAND ATTN: AMSTA-LC-CECT 15 KANSAS STREET NATICK, MA 01760-5052						<b>FROM:</b> (Activity and location) (Include ZIP Code)  <i>PFC Jane Doe</i> <i>CO A 3<sup>rd</sup> Engineer BR</i> <i>Ft. Leonardwood, MO 63108</i>	
<b>PART I – ALL PUBLICATIONS (EXCEPT RPSTL AND SC/SM) AND BLANK FORMS</b>							
<b>PUBLICATION/FORM NUMBER</b> TM 10-1670-296-23&P				<b>DATE</b> 30 October 2002	<b>TITLE</b> Unit Manual for Ancillary Equipment for Low Velocity Air Drop Systems		
<b>ITEM NO.</b>	<b>PAGE NO.</b>	<b>PARA-GRAPH</b>	<b>LINE NO. *</b>	<b>FIGURE NO.</b>	<b>TABLE NO.</b>	<b>RECOMMENDED CHANGES AND REASON</b> <i>(Provide exact wording of recommended changes, if possible).</i>	
	0036 00-2				1	<i>In table 1, Sewing Machine Code Symbols, the second sewing machine code symbol should be MD ZZ not MD 22.</i>  <i>Change the manual to show Sewing Machine, Industrial: Zig-Zag; 308 stitch; medium-duty; NSN 3530-01-181-1421 as a MD ZZ code symbol.</i>	
<small>*Reference to line numbers within the paragraph or subparagraph.</small>							
<b>TYPED NAME, GRADE OR TITLE</b>  Jane Doe, PFC				<b>TELEPHONE EXCHANGE/AUTOVON, PLUS EXTENSION</b>  508-233-4141		<b>SIGNATURE</b>  Jane Doe <i>Jane Doe</i>	

<b>TO:</b> <i>(Forward direct to addressee listed in publication)</i> COMMANDER U.S. ARMY TANK-AUTOMOTIVE AND ARMAMENT COMMAND ATTN: AMSTA-LC-CECT 15 KANSAS STREET NATICK, MA 01760-5052	<b>FROM:</b> <i>(Activity and location) (Include ZIP Code)</i> <i>PFC Jane Doe</i> <i>CO A 3<sup>rd</sup> Engineer BR</i> <i>Ft. Leonardwood, MO 63108</i>	<b>DATE</b> 21 October 2003
--	---	--------------------------------

**PART II – REPAIR PARTS AND SPECIAL TOOL LISTS AND SUPPLY CATALOGS/SUPPLY MANUALS**

<b>PUBLICATION NUMBER</b> TM 10-1670-296-23&P	<b>DATE</b> 30 October 2002	<b>TITLE</b> Unit Manual for Ancillary Equipment for Low Velocity Air Drop Systems
--	--------------------------------	---

PAGE NO.	COLM NO.	LINE NO.	NATIONAL STOCK NUMBER	REFERENCE NO.	FIGURE NO.	ITEM NO.	TOTAL NO. OF MAJOR ITEMS SUPPORTED	RECOMMENDED ACTION
0066 00-1					4			<i>Callout 16 in figure 4 is pointed to a <u>D-Ring</u>. In the Repair Parts List key for figure 4, item 16 is called a <u>Snap Hook</u>. Please correct one or the other.</i>

**PART III – REMARKS** *(Any general remarks or recommendations, or suggestions for improvement of publications and blank forms. Additional blank sheets may be used if more space is needed.)*

--	--	--

TYPED NAME, GRADE OR TITLE	TELEPHONE EXCHANGE/AUTOVON, PLUS EXTENSION	SIGNATURE
----------------------------	--	-----------

<p align="center"><b>RECOMMENDED CHANGES TO PUBLICATIONS AND BLANK FORMS</b></p> <p>For use of this form, see AR 25-30; the proponent agency is ODISC4.</p>						Use Part II (reverse) for Repair Parts and Special Tool Lists (RPSTL) and Supply Catalogs/Supply Manuals (SC/SM).	DATE
<b>TO:</b> (Forward to proponent of publication or form) (Include ZIP Code) COMMANDER U.S. ARMYTANK-AUTOMOTIVE AND ARMAMENT COMMAND ATTN: AMSTA-LC-CECT 15 KANSAS STREET NATICK, MA 01760-5052						<b>FROM:</b> (Activity and location) (Include ZIP Code)	
<b>PART I – ALL PUBLICATIONS (EXCEPT RPSTL AND SC/SM) AND BLANK FORMS</b>							
PUBLICATION/FORM NUMBER TM 10-8340-240-12&P				DATE 30 June 2005		TITLE Operator's and Unit Maintenance Manual, Including Repair Parts and Special Tools List, Modular General Purpose Tent System (MGPTS)	
ITEM NO.	PAGE NO.	PARA-GRAPH	LINE NO. *	FIGURE NO.	TABLE NO.	RECOMMENDED CHANGES AND REASON <i>(Provide exact wording of recommended changes, if possible).</i>	
<i>*Reference to line numbers within the paragraph or subparagraph.</i>							
TYPED NAME, GRADE OR TITLE				TELEPHONE EXCHANGE/AUTOVON, PLUS EXTENSION		SIGNATURE	

<b>TO:</b> (Forward direct to addressee listed in publication) COMMANDER U.S. ARMYTANK-AUTOMOTIVE AND ARMAMENT COMMAND ATTN: AMSTA-LC-CECT 15 KANSAS STREET NATICK, MA 01760-5052	<b>FROM:</b> (Activity and location) (Include ZIP Code)	<b>DATE</b>
--	---	-------------

**PART II – REPAIR PARTS AND SPECIAL TOOL LISTS AND SUPPLY CATALOGS/SUPPLY MANUALS**

<b>PUBLICATION NUMBER</b> TM 10-8340-240-12&P	<b>DATE</b> 30 June 2005	<b>TITLE</b> Operator's and Unit Maintenance Manual, Including Repair Parts and Special Tools List, Modular General Purpose Tent System (MGPTS)
--	-----------------------------	---

PAGE NO.	COLM NO.	LINE NO.	NATIONAL STOCK NUMBER	REFERENCE NO.	FIGURE NO.	ITEM NO.	TOTAL NO. OF MAJOR ITEMS SUPPORTED	RECOMMENDED ACTION

**PART III – REMARKS** (Any general remarks or recommendations, or suggestions for improvement of publications and blank forms. Additional blank sheets may be used if more space is needed.)

TYPED NAME, GRADE OR TITLE	TELEPHONE EXCHANGE/AUTOVON, PLUS EXTENSION	SIGNATURE
----------------------------	--	-----------



<p align="center"><b>RECOMMENDED CHANGES TO PUBLICATIONS AND BLANK FORMS</b></p> <p>For use of this form, see AR 25-30; the proponent agency is ODISC4.</p>						Use Part II (reverse) for Repair Parts and Special Tool Lists (RPSTL) and Supply Catalogs/Supply Manuals (SC/SM).	DATE
<b>TO:</b> (Forward to proponent of publication or form) (Include ZIP Code) COMMANDER U.S. ARMYTANK-AUTOMOTIVE AND ARMAMENT COMMAND ATTN: AMSTA-LC-CECT 15 KANSAS STREET NATICK, MA 01760-5052						<b>FROM:</b> (Activity and location) (Include ZIP Code)	
<b>PART I – ALL PUBLICATIONS (EXCEPT RPSTL AND SC/SM) AND BLANK FORMS</b>							
PUBLICATION/FORM NUMBER TM 10-8340-240-12&P				DATE 30 June 2005	TITLE Operator's and Unit Maintenance Manual, Including Repair Parts and Special Tools List, Modular General Purpose Tent System (MGPTS)		
ITEM NO.	PAGE NO.	PARA-GRAPH	LINE NO. *	FIGURE NO.	TABLE NO.	RECOMMENDED CHANGES AND REASON (Provide exact wording of recommended changes, if possible).	
*Reference to line numbers within the paragraph or subparagraph.							
TYPED NAME, GRADE OR TITLE				TELEPHONE EXCHANGE/AUTOVON, PLUS EXTENSION		SIGNATURE	

<b>TO:</b> (Forward direct to addressee listed in publication) COMMANDER U.S. ARMYTANK-AUTOMOTIVE AND ARMAMENT COMMAND ATTN: AMSTA-LC-CECT 15 KANSAS STREET NATICK, MA 01760-5052	<b>FROM:</b> (Activity and location) (Include ZIP Code)	<b>DATE</b>
--	---	-------------

**PART II – REPAIR PARTS AND SPECIAL TOOL LISTS AND SUPPLY CATALOGS/SUPPLY MANUALS**

<b>PUBLICATION NUMBER</b> TM 10-8340-240-12&P	<b>DATE</b> 30 June 2005	<b>TITLE</b> Operator's and Unit Maintenance Manual, Including Repair Parts and Special Tools List, Modular General Purpose Tent System (MGPTS)
--	-----------------------------	---

PAGE NO.	COLM NO.	LINE NO.	NATIONAL STOCK NUMBER	REFERENCE NO.	FIGURE NO.	ITEM NO.	TOTAL NO. OF MAJOR ITEMS SUPPORTED	RECOMMENDED ACTION

**PART III – REMARKS**

*(Any general remarks or recommendations, or suggestions for improvement of publications and blank forms. Additional blank sheets may be used if more space is needed.)*

Empty space for remarks
-------------------------

<b>TYPED NAME, GRADE OR TITLE</b>	<b>TELEPHONE EXCHANGE/AUTOVON, PLUS EXTENSION</b>	<b>SIGNATURE</b>
-----------------------------------	---	------------------

# The Metric System and Equivalents

## Linear Measure

1 centimeter = 10 millimeters = .39 inch  
 1 decimeter = 10 centimeters = 3.94 inches  
 1 meter = 10 decimeters = 39.37 inches  
 1 dekameter = 10 meters = 32.8 feet  
 1 hectometer = 10 dekameters = 328.08 feet  
 1 kilometer = 10 hectometers = 3,280.8 feet

## Weights

1 centigram = 10 milligrams = .15 grain  
 1 decigram = 10 centigrams = 1.54 grains  
 1 gram = 10 decigrams = .035 ounce  
 1 dekagram = 10 grams = .35 ounce  
 1 hectogram = 10 dekagrams = 3.52 ounces  
 1 kilogram = 10 hectograms = 2.2 pounds  
 1 quintal = 100 kilograms = 220.46 pounds  
 1 metric ton = 10 quintals = 1.1 short tons

## Liquid Measure

1 centiliter = 10 milliliters = .34 fl. ounce  
 1 deciliter = 10 centiliters = 3.38 fl. ounces  
 1 liter = 10 deciliters = 33.81 fl. ounces  
 1 dekaliter = 10 liters = 2.64 gallons  
 1 hectoliter = 10 dekaliters = 26.42 gallons  
 1 kiloliter = 10 hectoliters = 264.18 gallons

## Square Measure

1 sq. centimeter = 100 sq. millimeters = .155 sq. inch  
 1 sq. decimeter = 100 sq. centimeters = 15.5 sq. inches  
 1 sq. meter (centare) = 100 sq. decimeters = 10.76 sq. feet  
 1 sq. dekameter (are) = 100 sq. meters = 1,076.4 sq. feet  
 1 sq. hectometer (hectare) = 100 sq. dekameters = 2.47 acres  
 1 sq. kilometer = 100 sq. hectometers = .386 sq. mile

## Cubic Measure

1 cu. centimeter = 1000 cu. millimeters = .06 cu. inch  
 1 cu. decimeter = 1000 cu. centimeters = 61.02 cu. inches  
 1 cu. meter = 1000 cu. decimeters = 35.31 feet

## Approximate Conversion Factors

<i>To change</i>	<i>To</i>	<i>Multiply by</i>	<i>To change</i>	<i>To</i>	<i>Multiply by</i>
inches	centimeters	2.540	ounce-inches	newton-meters	.007062
feet	meters	.305	centimeters	inches	.394
yards	meters	.914	meters	feet	3.280
miles	kilometers	1.609	meters	yards	1.094
square inches	square centimeters	6.451	kilometers	miles	.621
square feet	square meters	.093	square centimeters	square inches	.155
square yards	square meters	.836	square meters	square feet	10.764
square miles	square kilometers	2.590	square meters	square yards	1.196
acres	square hectometers	.405	square kilometers	square miles	.386
cubic feet	cubic meters	.028	square hectometers	acres	2.471
cubic yards	cubic meters	.765	cubic meters	cubic feet	35.315
fluid ounces	milliliters	29.573	cubic meters	cubic yards	1.308
pints	liters	.473	milliliters	fluid ounces	.034
quarts	liters	.946	liters	pints	2.113
gallons	liters	3.785	liters	quarts	1.057
ounces	grams	28.349	liters	gallons	.264
pounds	kilograms	.454	grams	ounces	.035
short tons	metric tons	.907	kilograms	pounds	2.205
pound-feet	newton-meters	1.356	metric tons	short tons	1.102
pound-inches	newton-meters	.11296			

## Temperature (Exact)

  °F Fahrenheit temperature  $\times \frac{5}{9}$  (after subtracting 32) = Celsius temperature   °C

**PIN: 078213-000**